

VERTICAL-WHEEL® BIOREACTORS

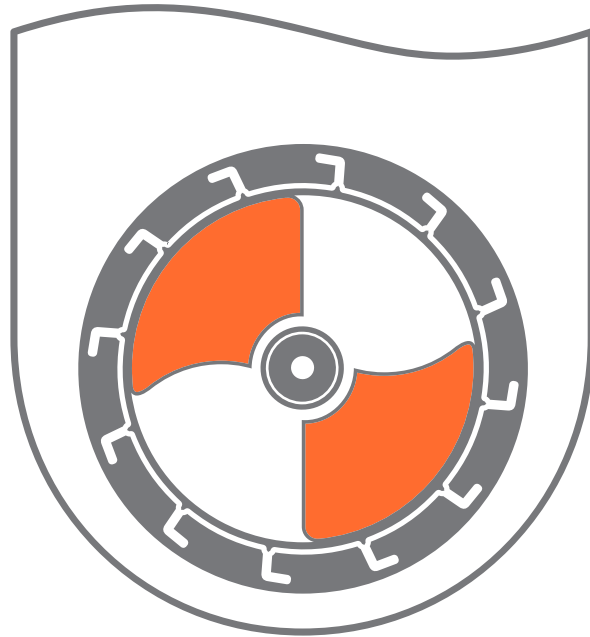

PBS-15 Vertical-Wheel®

PBS-80 Vertical-Wheel®

Reusable Sensors

Single-Use Bioreactor Systems

User Manual

Applicable Models: IA-15-B-501 | IA-15-B-502 | IA-80-B-511 | IA-80-B-512



PBS Biotech, Inc.

© 2026 PBS Biotech, Inc. All rights reserved. All text, images, graphics and other materials in this manual are subject to the copyright and other intellectual property rights of PBS Biotech, Inc.

Under the copyright laws, this manual may not be copied, in whole or in part, without written consent of PBS Biotech, Inc.

The marks appearing in this manual including, but not limited to: (i) PBS Biotech and the PBS Biotech logo; (ii) Vertical-Wheel® Bioreactor and its logo, emblem, slogans and model names and designs are trademarks of PBS Biotech, Inc., and registered in the U.S. and other countries.

Other company and product names mentioned herein may be trademarks of their respective companies. Mention of third-party products is for informational purposes only and constitutes neither an endorsement nor a recommendation. PBS Biotech, Inc. assumes no responsibility with regard to the performance or use of these products.

This User Manual reflects the latest product updates available at the time of publication. While every effort has been made to ensure accuracy, specifications and features may change. Please refer to the most recent product information on our website for the most up-to-date details regarding your bioreactor system.

PBS Biotech, Inc. is not responsible for printing or clerical errors.

This manual is intended as a guide to provide the user with necessary instructions on the proper use and maintenance of the PBS-15/80 Bioreactor Systems. This manual should be used in conjunction with instruction and training supplied by qualified PBS Biotech, Inc. personnel.

Any failure to follow the instructions as described, including use of materials or products not approved or recommended by PBS Biotech, Inc., could result in impaired product function, injury to the user or others, or void applicable product warranties. PBS Biotech, Inc. accepts no responsibility for liability resulting from improper use or maintenance of its products.

Utilization of PBS Biotech, Inc. products may require the user to handle and dispose of biohazardous materials. Users must fully understand and implement all regulations regarding the safe handling of biohazardous products and waste, including the policies and procedures of their facility.

PBS Biotech, Inc.
4721 Calle Carga
Camarillo, California 93012
+1 (805) 482-7272
www.pbsbiotech.com

Contents

Preface	12	About This Manual
Chapter 1	13	PBS-15/80 at a Glance
	13	Definitions
	14	PBS-15 Bioreactor - Front
	16	PBS-15 Bioreactor - Side Cabinet
	18	PBS-15 Bioreactor - Rear
	20	PBS-15 Bioreactor - Bag
	24	PBS-15 Bioreactor - Accessories
	26	PBS-80 Bioreactor - Front
	28	PBS-80 Bioreactor - Side Cabinet
	30	PBS-80 Bioreactor - Rear
	32	PBS-80 Bioreactor - Bag
	34	PBS-80 Bioreactor - Accessories
	36	PBS-15/80 Hello User Interface
	38	PBS-15/80 Desktop User Interface
Chapter 2	40	System Description
	40	System Description
	40	Principles of Operation
	40	Agitation
	41	Heating
	41	Dissolved Oxygen
	41	pH
	41	Level
	41	Filter Oven and Condenser Bag
	42	Pressure
	42	Overview of PBS Software Functionality and Architecture
	42	Functionality
	42	Sensing and Control
	43	Data Acquisition and Reporting
	43	Process and Failure Alarms
	43	Task Automation
	43	Remote Monitoring and Control
	44	Administration
	44	Architecture
Chapter 3	45	Safety
	46	Supplier's Declaration of Conformity (USA)
	47	Inspections and Preventative Maintenance
	47	Inspections
	48	Preventative Maintenance

	48	Cleaning and Decontamination
	49	Lifting and Handling
	49	PBS-15
	49	PBS-80
Chapter 4	50	Product Specifications
	50	General
	51	Bioreactor Geometry
	51	Controls
	51	Agitation
	51	Gassing
	52	Temperature
	52	Dissolved Oxygen
	52	pH
	52	Level
	52	Pressure
	53	Pumps
	53	Single-Use Bag
	54	Service Life
	54	Safety and Regulatory
Chapter 5	55	Installing the PBS-15/80
	55	Integrated Bioreactor
	55	Minimum Space Requirements
	55	Utility Requirements
	56	PBS-15
	56	PBS-80
	56	Unit Placement
	56	PBS-15
	57	PBS-80
	57	Connecting the Drip Collection Line
	57	Powering On the PBS-15/80
	57	Configuring Users and Groups
	58	Creating a New User Group
	60	Editing Group Permissions
	60	Editing Group Password Settings
	61	Creating a New User
	62	Modifying User Accounts
	63	Users' Own Accounts
	64	Naming the PBS-15/80
	66	Configuring Logger Settings
	69	Configuring Alarm Settings
	73	Configuring Automatic Backups
	73	Setting Automatic Backup Period
	74	Setting Automatic Backup Location

Chapter 6	76	Using the PBS-15/80
	76	Before You Begin
	76	Suggested Order of Operations
	76	Set Up Run
	77	During Run
	77	End Run
	77	Before Starting a Batch Run
	77	Log In to the Hello UI
	78	Restarting the HMI Computer
	79	Calibrating Reusable pH Sensor
	79	Before calibrating
	80	Two-point pH calibration
	81	Calibrating Reusable Dissolved Oxygen Sensor
	81	Before calibrating
	81	Two-point DO calibration
	83	Autoclaving Reusable Sensors
	84	Load Bag
	84	Install Bag in PBS-15/80
	88	Check Oxygen Flow Valve Configuration
	89	Check Harvest Valve Alignment with Harvest Mode
	90	Pressure 'Zero' Calibration
	91	Level 'Zero' Calibration
	92	Integrity Test
	94	Install Sensors
	95	To install a reusable DO sensor
	98	To install a reusable pH sensor
	99	Finish sensor installation:
	99	Second Integrity Test
	99	Starting a Run
	99	Using the Pumps
	100	Tube holder positioning for smaller pumps
	102	Tube holder positioning for larger pumps
	103	Tube loading for smaller pumps
	103	Tube loading for larger pumps
	104	Using gravity
	104	Accessing the Pumps menu
	105	Adding Medium
	106	Priming the Harvest Line
	106	Level 'Span' Calibration
	107	Turning Controls On
	110	'Span'/'One-Point' Calibrations After Equilibration
	110	'One-point'/'Span' DO calibration
	112	'One-point' pH calibration

113	Selecting a Base Pump
113	Adding Additional Fluids
114	Load the Alarms On.alm File
114	Inoculate with Cells
115	Entering Batch Name
116	Take Sample
116	116 PBS-15/80 bag's sample line
116	116 To take a sample with the bag's sample line and a pump
118	Exchanging Medium
119	Harvesting a Run
121	Other Features
121	Filter Oven
122	Recipes
122	122 Creating or editing recipes
123	123 Configuring recipes
123	123 Running recipes
124	Manually Archiving DBs
125	Managing Files
126	Generating Reports
126	126 To generate reports from the active database
128	128 To generate reports from archived databases
131	Light
132	Advanced View
132	Show Desktop
132	Shutdown
133	Alarms
134	Settings/System Variables
134	134 To change settings with the Hello UI
135	135 To change settings with the Desktop UI
137	Remote Access
138	Oxygen Flow Valve
138	Reboot RIO
139	Other Calibrations
Chapter 7	140 Understanding the PBS-15/80
140	Hello User Interface
140	Desktop User Interface
140	Interlocks
141	Agitation
141	141 Off Mode
141	141 Manual Mode
141	141 Auto Mode
141	141 Lookup Mode

	142	Harvest Mode
	142	Output Ranges
	142	Relevant Settings
	143	Interlocks
143		Temperature
	143	Off Mode
	143	Manual Mode
	143	Auto Mode
	143	Broken Sensor Mode
	144	Output Ranges
	144	Relevant Settings
	144	Interlocks
145		Main Gas
	145	Relevant Settings
	146	Interlocks
146		Dissolved Oxygen
	146	Off Mode
	146	Manual Mode
	147	Auto Mode
	147	Broken Sensor Mode
	148	Output Ranges
	148	Relevant Settings
	149	Interlocks
149		pH
	150	Off Mode
	150	Manual Mode
	151	Auto Mode
	151	Broken Sensor Mode
	152	Output Ranges
	152	Relevant Settings
	153	Interlocks
153		Level Sensing
	153	Disconnecting the Level Sensing Line
	155	Relevant Settings
155		Filter Oven
	155	Off Mode
	155	Manual Mode
	155	Auto Mode
	156	Broken Sensor Mode
	156	Output Ranges
	156	Relevant Settings
	156	Interlocks
156		Pressure Sensing
	157	Relevant Settings

157	Leak Sensing	
157	Control Pumps	
157	Types (Media and Additions A and B)	
157	Relevant Settings	
158	Interlocks	
158	Main Light	
158	Door	
158	Relevant Settings	
159	Interlocks	
159	Calibrating/Configuring Sensors	
159	Pre-Calibration Medium Conditioning Strategy	
161	Selecting Sensors	
162	Which Sensors Can Be Calibrated	
162	Dissolved Oxygen	
163	pH	
163	Level	
163	Temperature	
163	Filter Oven Temperature	
163	Pressure	
163	Temperature Compensation	
164	Calibration Types	
164	Zero	
165	Two-point	
166	Span and Offset	
167	Manual	
167	Recipes	
167	Actions and Looping	
168	Which Variable Types Recipes Can Change	
168	User Source	
168	System Source	
168	Sensor and Calculated Sources	
169	Other Information About Recipes	
169	Reports	
169	Types	
170	Process Data Recording	
171	Database	
171	Take Sample	
171	Sampling for Cell Counting	
172	Sampling for pH Measurement	
173	Sampling for DO Measurement	
173	Load Bag	
174	Batch	
174	Advanced View	
174	Windows/HMI Log Off	

	174	Restart
	174	Alarms
	176	Settings
	176	User Accounts
	176	User Group Permissions
	176	Desktop User Interface Permissions
	177	Hello User Interface Permissions
	178	Common Permissions
	179	Oxygen Flow Valve
Chapter 8	180	Instructions for IT
	180	Bioreactor Computer Architecture
	180	Operating System
	181	BIOS
	182	Network Connections
	183	Email
	185	Remote Access (not LogMeIn)
	185	Backups
	186	McAfee Application and Change Control
	187	Automatic Updates
Appendix 1	188	Settings/System Variables
	188	Temperature
	190	Filter Oven
	191	Agitation
	194	pH
	199	DO
	203	Level
	204	Pressure
	205	Gas Data
	208	Safety
	210	Pumps
	210	Process Alarms
	213	System
Appendix 2	215	Alarms Definitions
Appendix 3	220	Default Alarms Configurations
Appendix 4	224	Default Logger Configurations and Global Variables Definitions
	224	Agitation
	229	Alarm
	229	Calibration
	233	DO
	239	Door
	240	Filter Oven

242	Gases
246	Interlocks
247	LEDs
248	Level
249	Process Alarms/Limits
253	Logger
254	Main Gas
254	Pressure
255	Pumps and Valves
262	Recipe
263	System
264	Temperature
268	pH

This page intentionally left blank.

About This Manual

This user manual shows you how to install, configure, and use both the PBS-15 Bioreactor System (PBS-15) and the PBS-80 Bioreactor System (PBS-80). Both systems will jointly be referred to as PBS-15/80 when they share common features and functions. This manual covers the Integrated Bioreactor, including the PBS Software package and the PBS-15/80 Bioreactor Single-Use Bag assembly.

Configurations are standard as of the time of publication and the software features and instructions are applicable to version 3.2.1. The “Software Release Version” can be viewed in the “About” tab of the Desktop User Interface.

The contents include:

- An overview of the PBS-15/80’s features, components, and controls (Chapter 1 on page 13)
- A high level system description to provide an understanding of the complete PBS-15/80 (Chapter 2 on page 40)
- Safety considerations (Chapter 3 on page 45)
- Product specifications (Chapter 4 on page 50)
- Instructions for installing the PBS-15/80 and configuring users, logger settings, and alarms (Chapter 5 on page 55)
- Day-to-day use of the PBS-15/80 (Chapter 6 on page 76)
- A detailed description of all PBS-15/80 features and functions (Chapter 7 on page 140)
- Information an IT department will need about the PBS-15/80 (Chapter 8 on page 180)

Note: Screenshots are illustrative of the Hello UI features and are not intended to show actual or recommended settings.

For More Information

For Frequently Asked Questions and more troubleshooting information, visit the PBS Biotech website at www.pbsbiotech.com, then navigate to Resources → FAQ.

For specific questions, email app.eng@pbsbiotech.com.

Use the illustrations in this chapter to become familiar with the basic features, components, and controls of the PBS-15/80.

Note: Some components may be slightly different from the illustrations here, depending on the configuration you purchased.

Definitions

PV = Present Value

SP = Set Point

UI = User Interface

LPM = Liters Per Minute

mLPM = Milliliters Per Minute

mL/min = Milliliters Per Minute

RPM = Revolutions Per Minute

CO₂ = Carbon Dioxide

N₂ = Nitrogen

O₂ = Oxygen

IPA = Isopropyl Alcohol

EtOH = Ethanol

MFC = Mass Flow Controller

RIO = Reconfigurable Input/Output

HMI = Human Machine Interface

BSC = Biosafety Cabinet

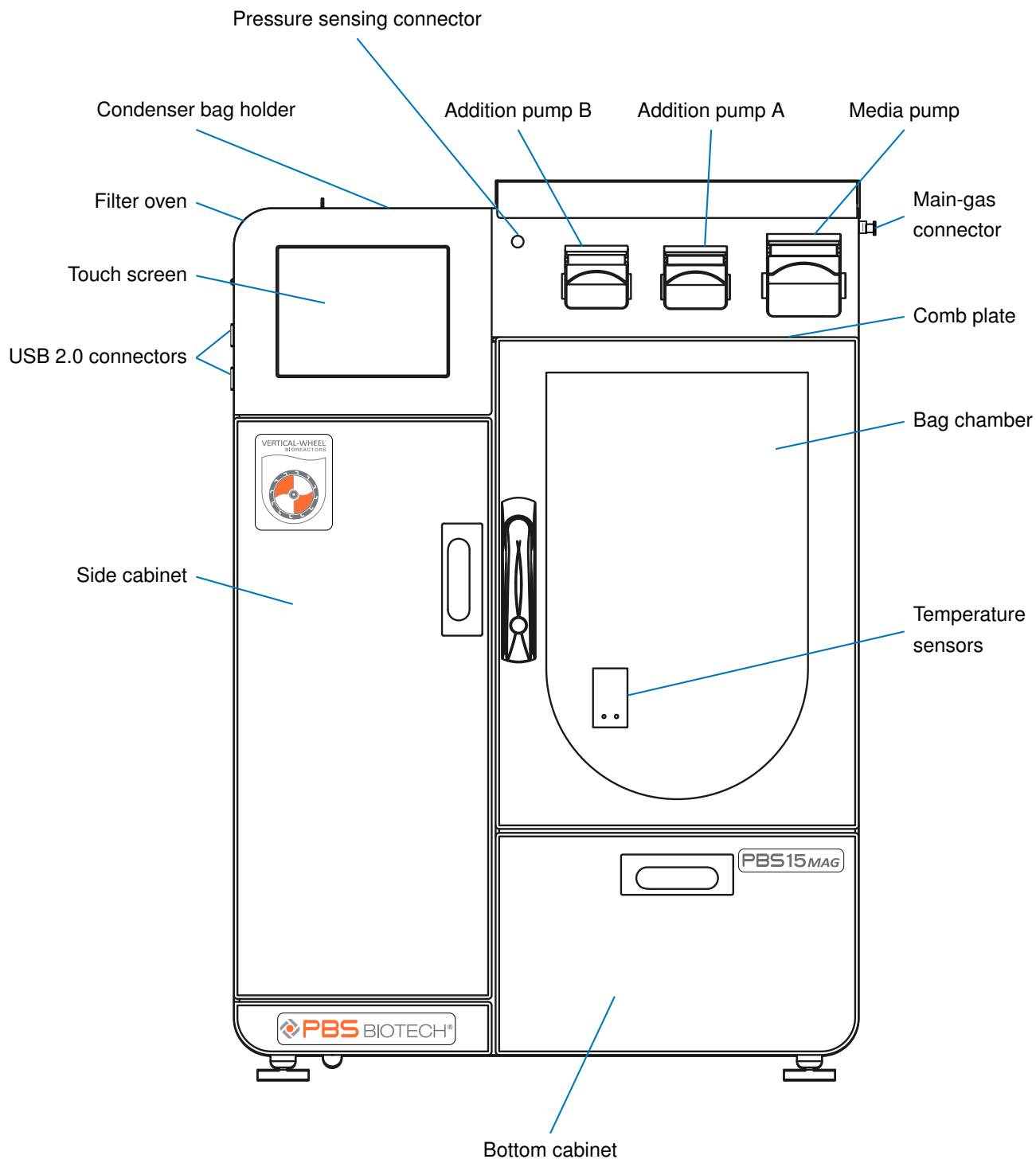

Touch screen

Responds to bare fingers, latex/nitrile gloves, or a stylus.

Filter oven

Keeps the exhaust filter at an elevated temperature to prevent clogging due to condensation of moisture from the exhaust gas.

Condenser bag holder

Stores the condenser bag.

Pressure sensing connector

Connects to the pressure sensing line on the bag. The software determines/detects a connection through a Hall effect sensor.

Addition pumps

Used with the bag's addition tubing to add base and other supplements/additions during a run.

Media pump

Used to fill the bag.

Main-gas connector

Connects the bag's Main-gas line to supplies of Air, CO₂, N₂, and O₂, which are attached to the bioreactor via the gas connection panel (see "PBS-15 Bioreactor - Rear" on page 18).

Comb plate

Prevents critical bag failure in the event of over-pressurization due to software error. The over-inflated bag will push this plate away from magnets holding it in place, resulting in power being cut to the MFCs, pumps, heaters and agitation.

Bag chamber

Holds the bag in place. Once the chamber door is opened, the bag is loaded through the front of the chamber.

Temperature sensors

Rest against the back of the bag to provide accurate temperature readings.

Bottom cabinet

Allows access to the harvest line.

Side cabinet

Stores and allows access to sensors and equipment that may be used less regularly.

USB 2.0 connectors

Allow connection of USB devices such as a keyboard, memory stick, or Wi-Fi adaptor.

NOTICE Avoid using keyboards with a power button, to prevent accidentally turning the bioreactor's HMI computer off.

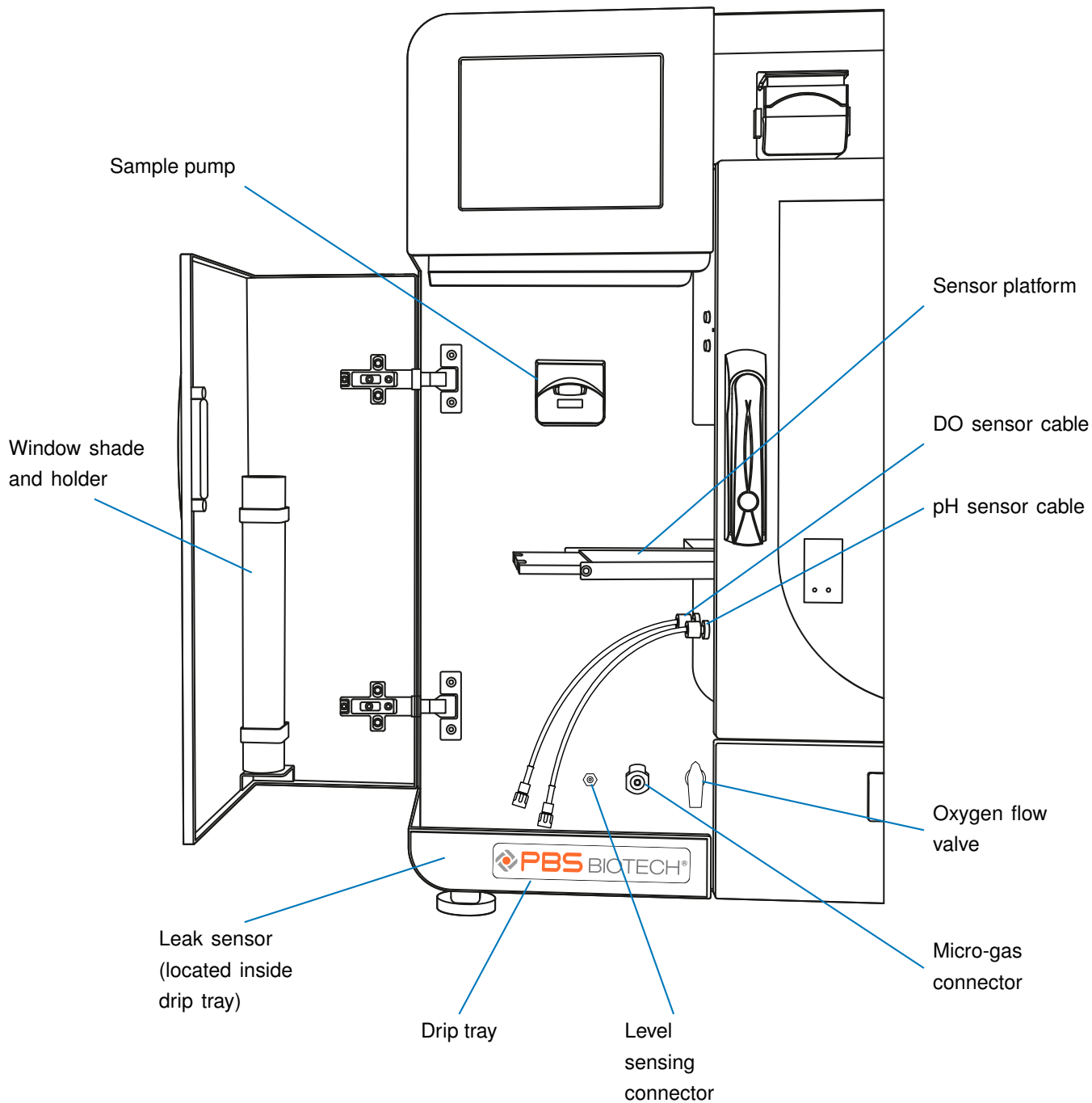

Sample pump

Used to draw a sterile sample from the bag.

Sensor platform

Holds the DO and pH sensors at an angle so they can provide accurate readings of the bag's contents.

Sensor cables

Connected to the DO and pH sensors after they have been installed in the bag.

Level sensing connector

Attaches to the level sensing line on the bag.

Oxygen flow valve

Controls how O₂ is delivered to the bag. When the valve is set to "Overlay," O₂ flows through the Main-gas line into the overlay. When the valve is set to "Sparger," O₂ is diverted from the Main-gas line to the Micro-gas line, where it is sparged from the bottom of the bag.

Micro-gas connector

Connects the bag's Micro-gas line to a supply of O₂, which is attached to the bioreactor via the gas connection panel (see "PBS-15 Bioreactor - Rear" on page 18).

Drip tray

Catches any media that leaks or overflows from the bag. The media will then flow down a drain and into the drip collection line (see "PBS-15 Bioreactor - Rear" on page 18).

Leak sensor

Detects leaks based on the presence of liquid in the drip tray. Stops reporting a leak once sensor contacts are dry.

Window shade and holder

Stores the Window shade in this holder when not in use.

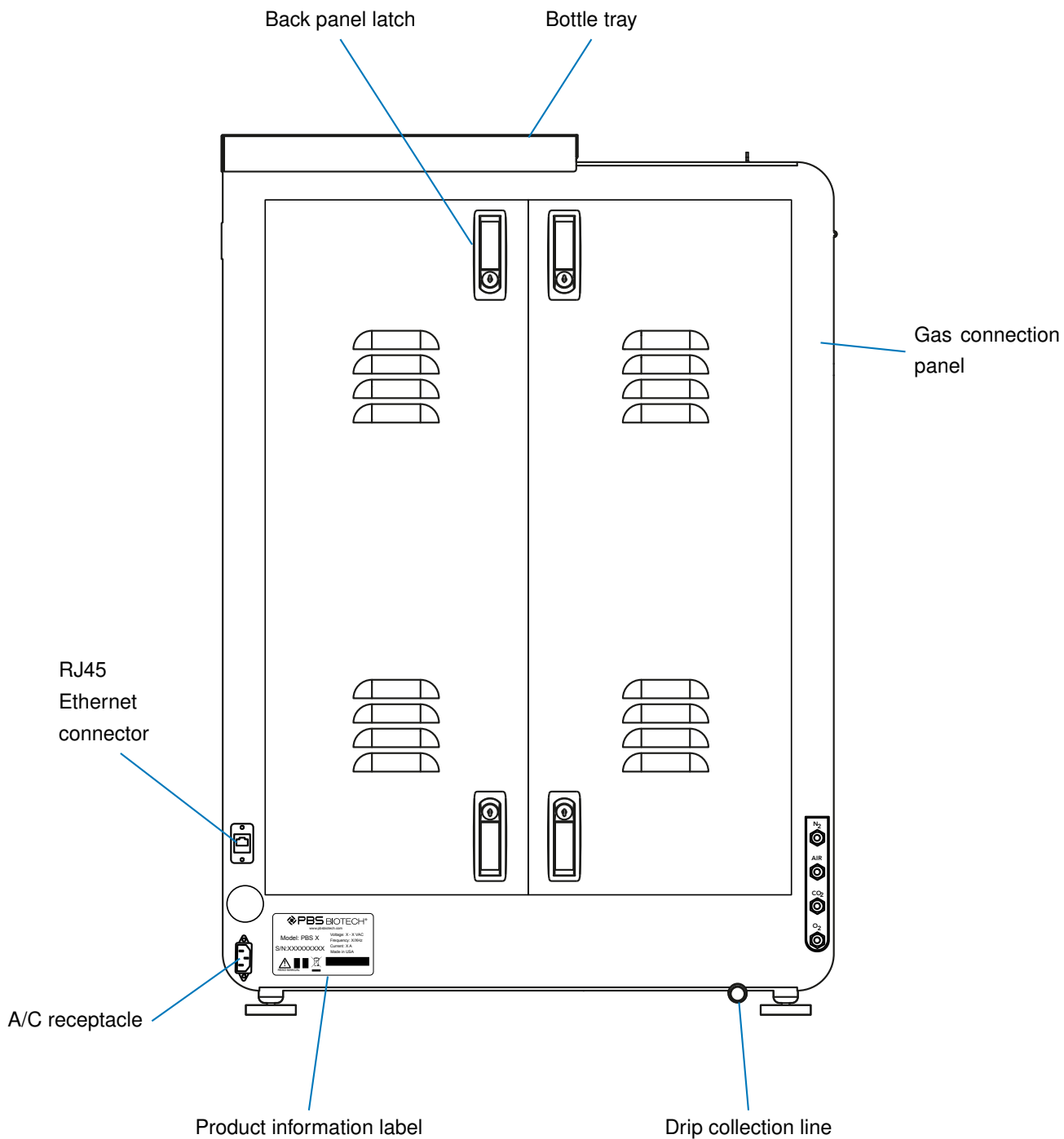

Bottle tray

Stores reagent or media addition bottles during a run.

Gas connection panel

Connects the external N₂, Air, CO₂, and O₂ supplies to the bioreactor (for specifics, see "Utility Requirements" on page 55).

NOTICE The gas connectors on the back of the bioreactor are push-to-connect connectors. Disconnecting the tubing requires pushing in the orange or gray connector, then pulling out the tubing. Improper removal of tubing can break the retaining clip and impact the holding capability/seal when tubing is reinstalled.

Drip collection line

Connects to a drip collection container to catch overflow/spills from the bag.

WARNING! As this is a gravity drain, ensure the collection container is below the level of the table and that the tubing runs downwards.

Product information label

Displays the bioreactor's serial and model numbers, as well as safety information.

A/C receptacle

Connects to a grounded outlet through a desired power cord to start up the bioreactor. There is no power switch on the bioreactor, to prevent it from being turned off accidentally.

RJ45 Ethernet connector

Used to connect the bioreactor to a high-speed Ethernet network.

Back panel latch

Secures the bioreactor's back cover and can be locked/unlocked with a supplied key.

This drawing of the bag is illustrative of general features and is not intended to represent any particular PBS product with 100% accuracy.

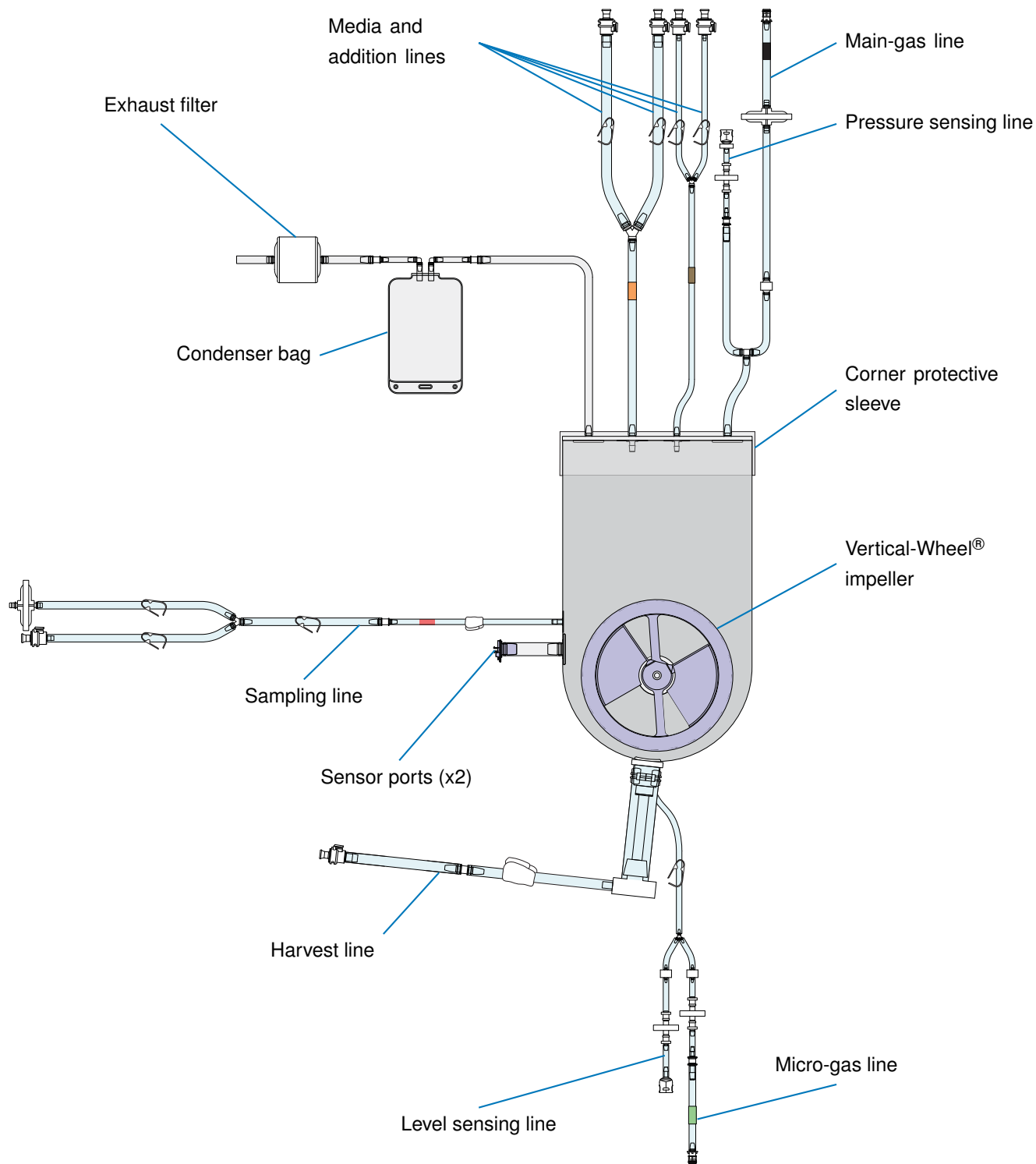

Exhaust filter

Filters the exhaust in order to maintain sterility of the bag contents.

Condenser bag

Catches droplets entrained in the exhaust, preventing them from clogging the exhaust filter.

Media and addition lines

Used with their respective pumps. The media line is used with the media pump to fill the bag at the start of a run or to add medium during a medium exchange. The addition lines are used to add base and other additions during a run.

Main-gas line

Connects to the bioreactor's Main-gas connector, which connects to external gas sources via the gas connection panel (see "PBS-15 Bioreactor - Rear" on page 18). Air, CO₂, N₂, and O₂ flow through this line to the overlay to control dissolved oxygen and pH. O₂ only flows through this line if the oxygen flow valve is set to "Overlay" (see "PBS-15 Bioreactor - Side Cabinet" on page 16).

Pressure sensing line

Senses the pressure inside the bag and provides data for the software's safety interlocks.

Corner protective sleeve

This is an additional layer of film meant to protect the top of the bag from damage. It is not to be removed.

Vertical-Wheel® impeller

Coupled to a driving motor by a set of magnets around its circumference. It has vanes for multidirectional mixing and a pair of magnets for RPM sensing.

Micro-gas line

Connects to the bioreactor's Micro-gas connector, which connects to external gas sources via the gas connection panel (see "PBS-15 Bioreactor - Rear" on page 18). O₂ is diverted from the Main-gas line to flow through this line to the sparger when the oxygen control valve is set to "Sparger" (see "PBS-15 Bioreactor - Side Cabinet" on page 16) to control dissolved oxygen.

Level sensing line

Senses the liquid level inside the bag by measuring the pressure required to push a small amount of air through the line. The line must be filled with air to work properly.

NOTICE Users must not allow this line to fill with liquid. If it must be disconnected while the bag contains liquid, first make sure there is no O₂ flow out of the Micro-gas line.

Next clamp the line as close to the bag as possible, then disconnect it.

Reconnect the line while it is still clamped and O₂ sparge flow is off. Then wait 1 to 2 minutes, then un-clamp the line. This allows air pressure to build up in the line, and when the clamp is opened the pressurized air will prevent liquid from entering the line.

For more information, see "Disconnecting the Level Sensing Line" on page 153.

Harvest line

Used to remove liquid during a medium exchange, empty the bag during a harvest run, or to transfer the bag's contents into a larger Vertical-Wheel® bioreactor. It can be drained with an external pump or drained by gravity.

Sensor ports (x2)

Accommodates one DO and one pH sensor in each port. They are installed using Kleenpak™ connectors to maintain sterility.

Sampling line

Used with the sample pump to remove a sterile sample.

NOTICE Depending on the model of bag being used, some of the tubing lines may not be compatible with the pumps installed on the PBS-15/80 and will require the use of an external pump.

This page intentionally left blank.

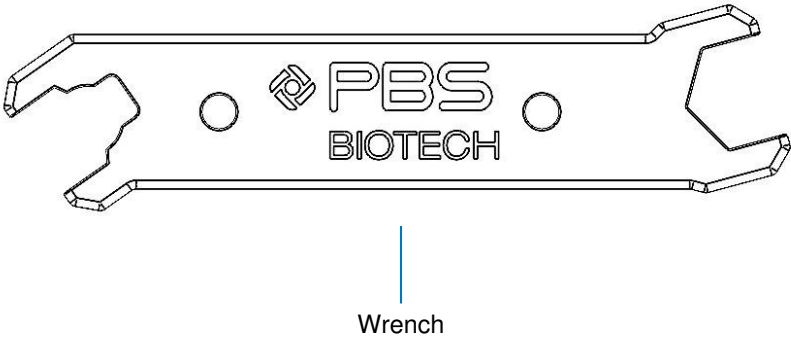
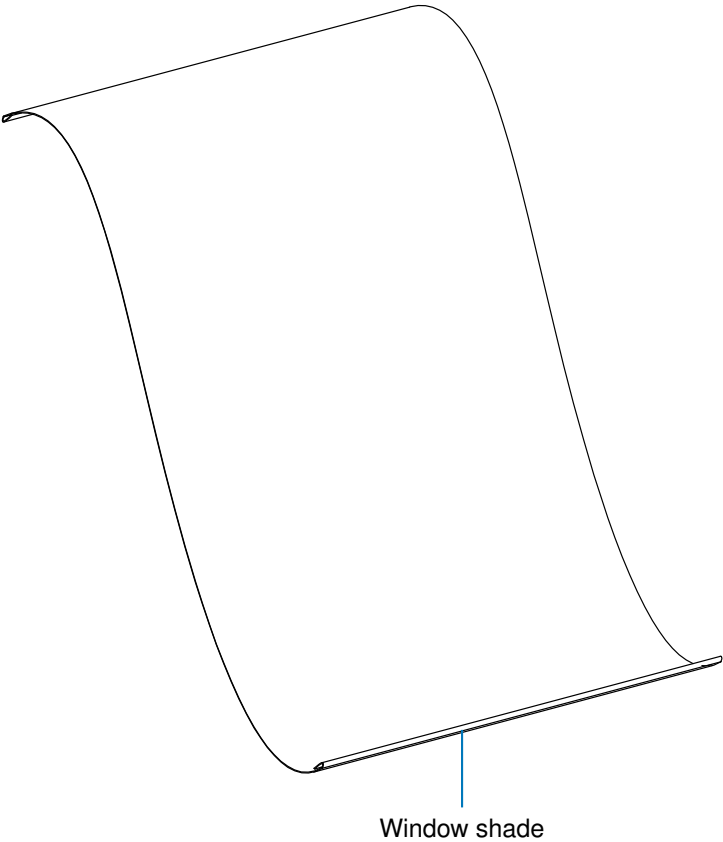

Window shade

Attaches to the door to protect light-sensitive media in the bag. Removable and stored in the Window shade holder when not in use. If it gets lost or damaged, the replacement part numbers are IA-15-BA-001 for the PBS-15, and IA-80-BA-001 for the PBS-80.

Wrench

Used for installing and removing sensors. If it gets lost or damaged, the replacement part number is IA-UNI-BA-005.

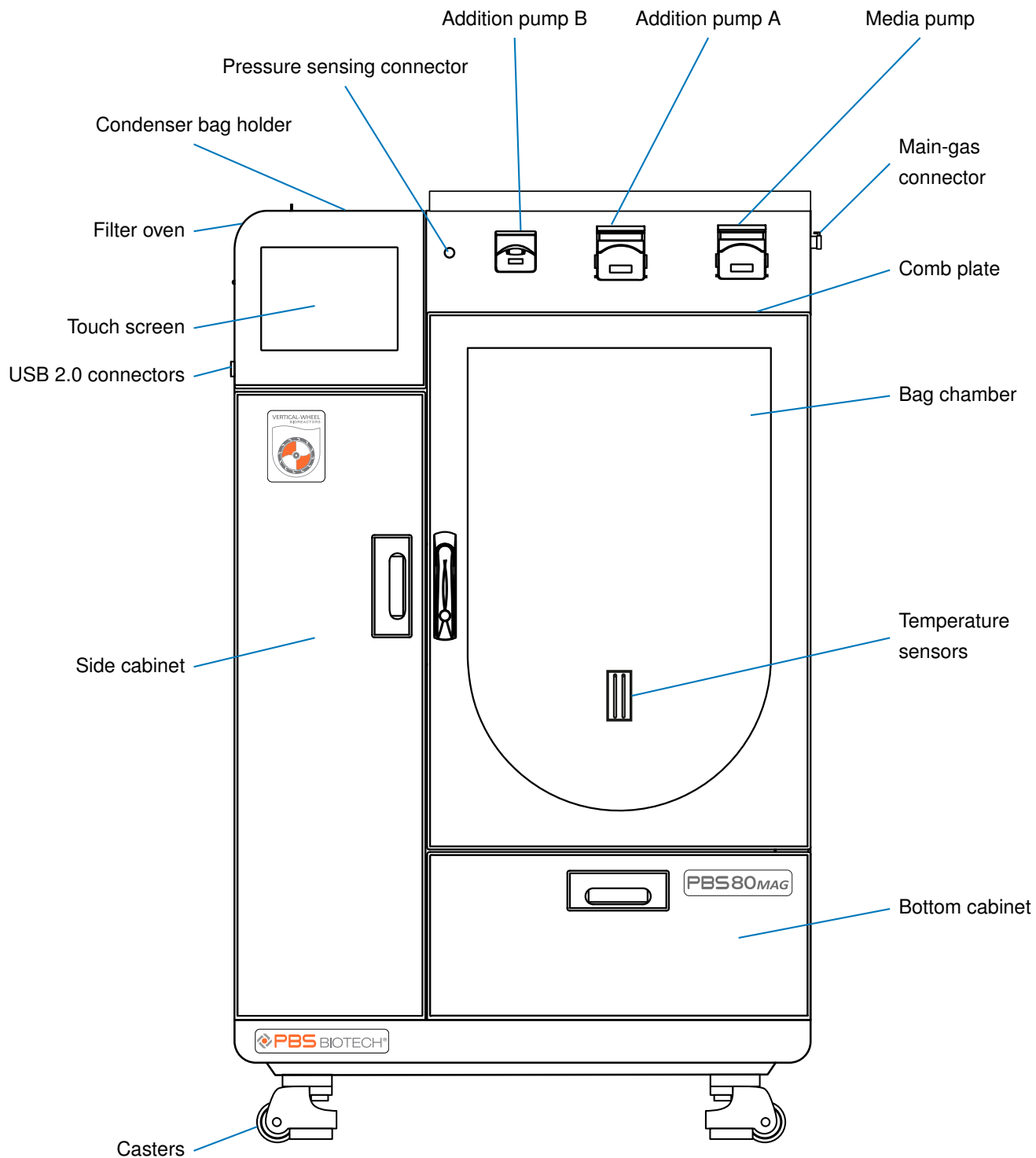

Touch screen

The definition is the same as the corresponding part of the PBS-15, but it should be noted that if a stylus is desired, only a capacitive stylus will work.

Casters

Allows the bioreactor to be moved when unlocked and prevents movement when locked.

The definitions of all other parts are the same as the corresponding parts of the PBS-15 (see “PBS-15 Bioreactor - Front” on page 14).

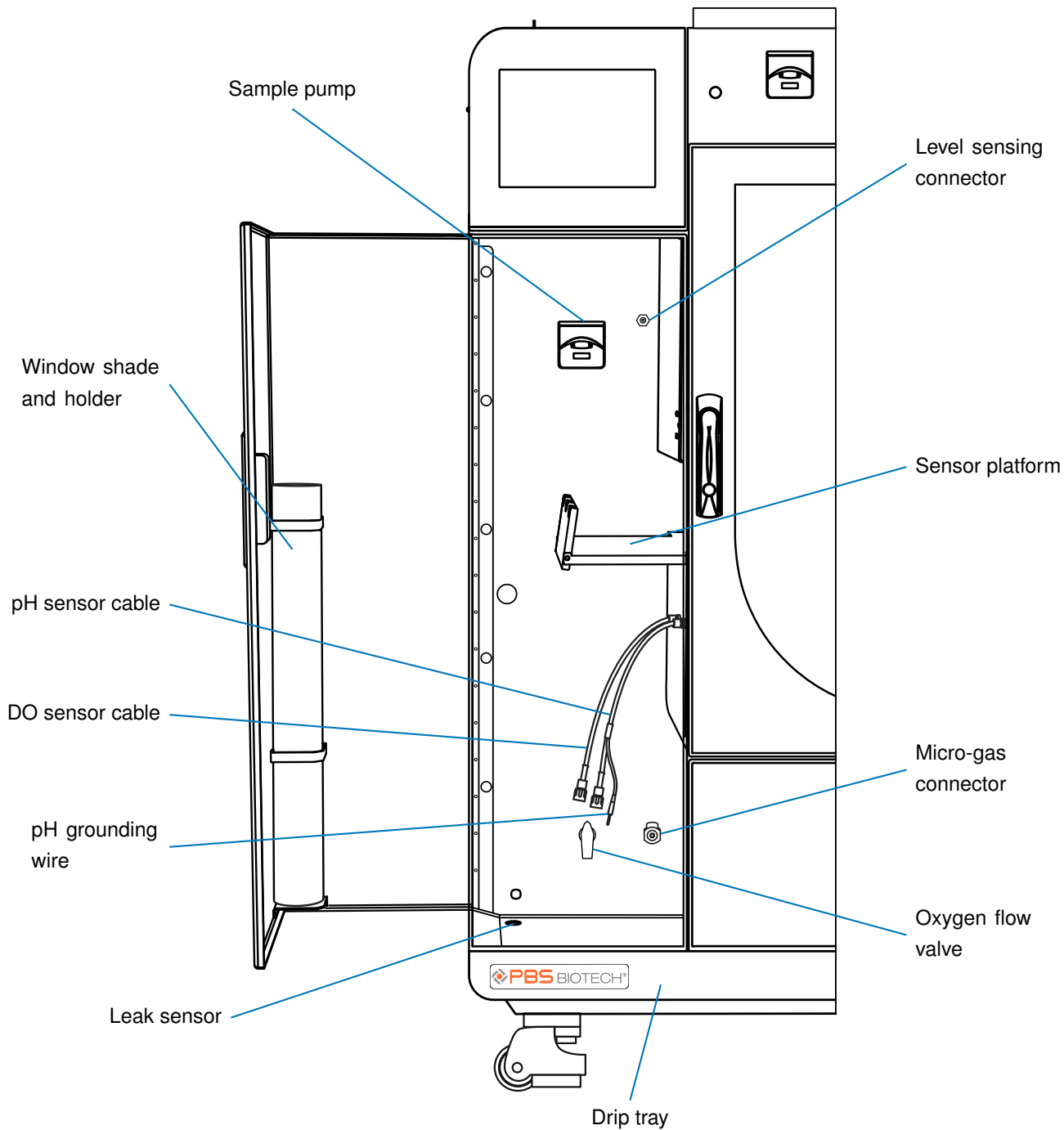

pH grounding wire

Grounds the pH sensor's transmitter to the measured liquid, using the metal body of the DO sensor as a conduit.

The definitions of all other parts are the same as the corresponding parts of the PBS-15 (see "PBS-15 Bioreactor - Side Cabinet" on page 16).

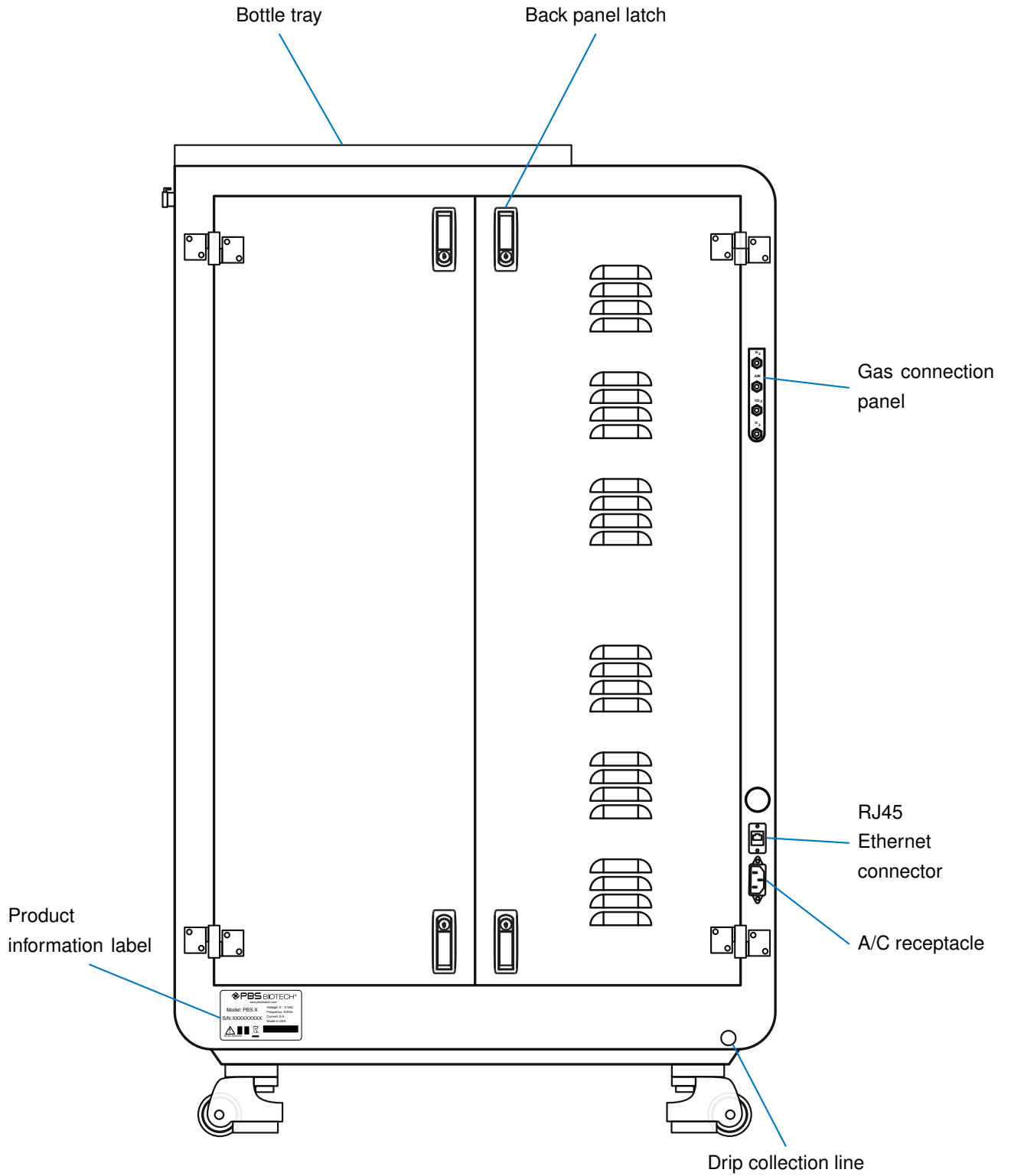

The definitions of all parts are the same as the corresponding parts of the PBS-15 (see “PBS-15 Bioreactor - Rear” on page 18).

This drawing of the bag is illustrative of general features and is not intended to represent any particular PBS product with 100% accuracy.

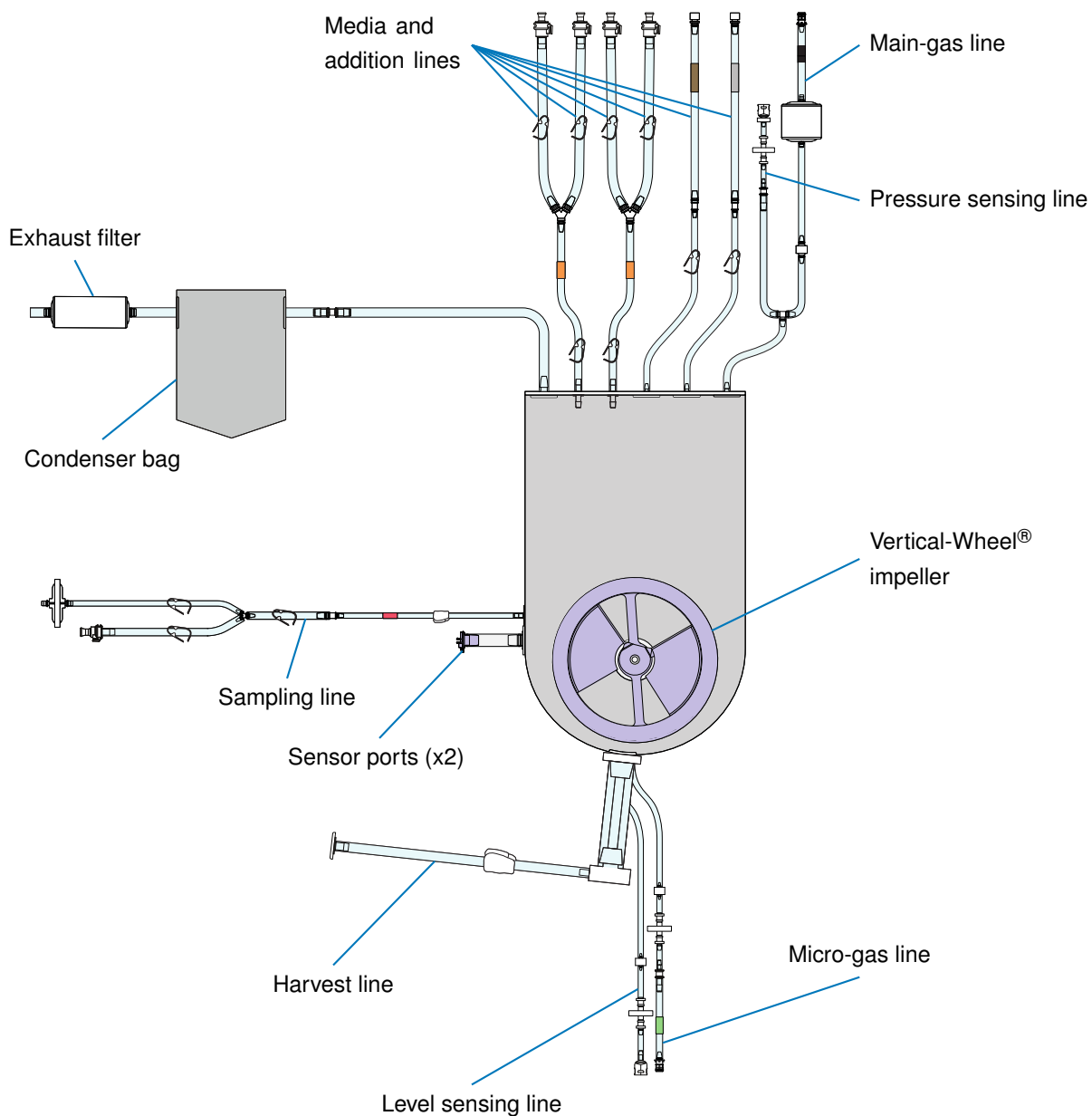

The definitions of all parts are the same as the corresponding parts of the PBS-15 (see “PBS-15 Bioreactor - Bag” on page 20).

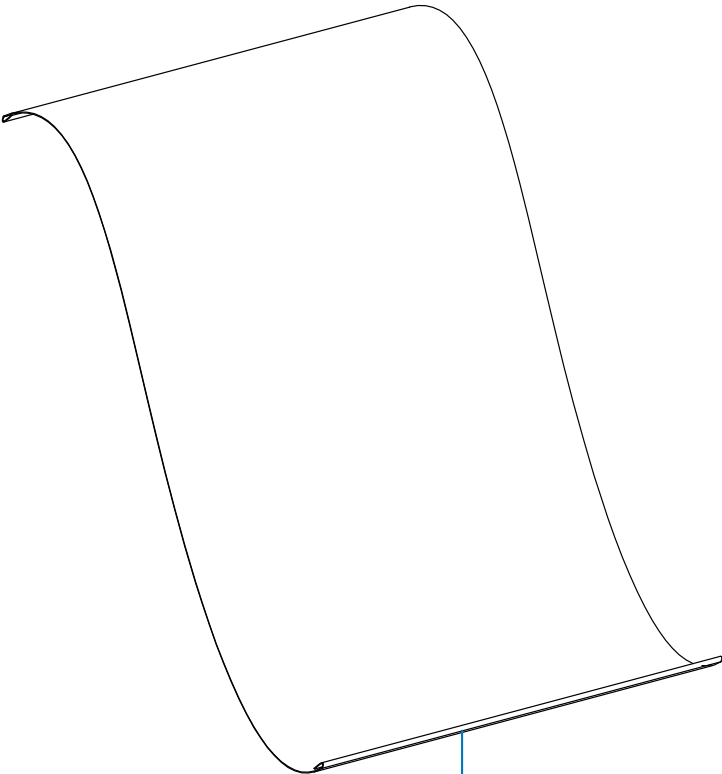

Window shade

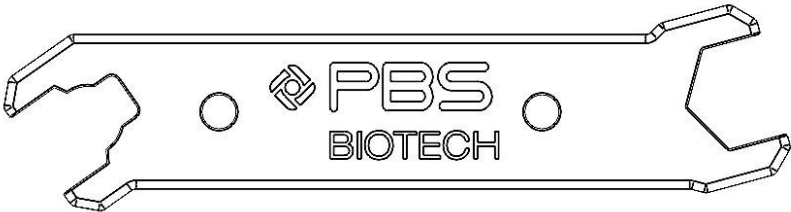

Wrench

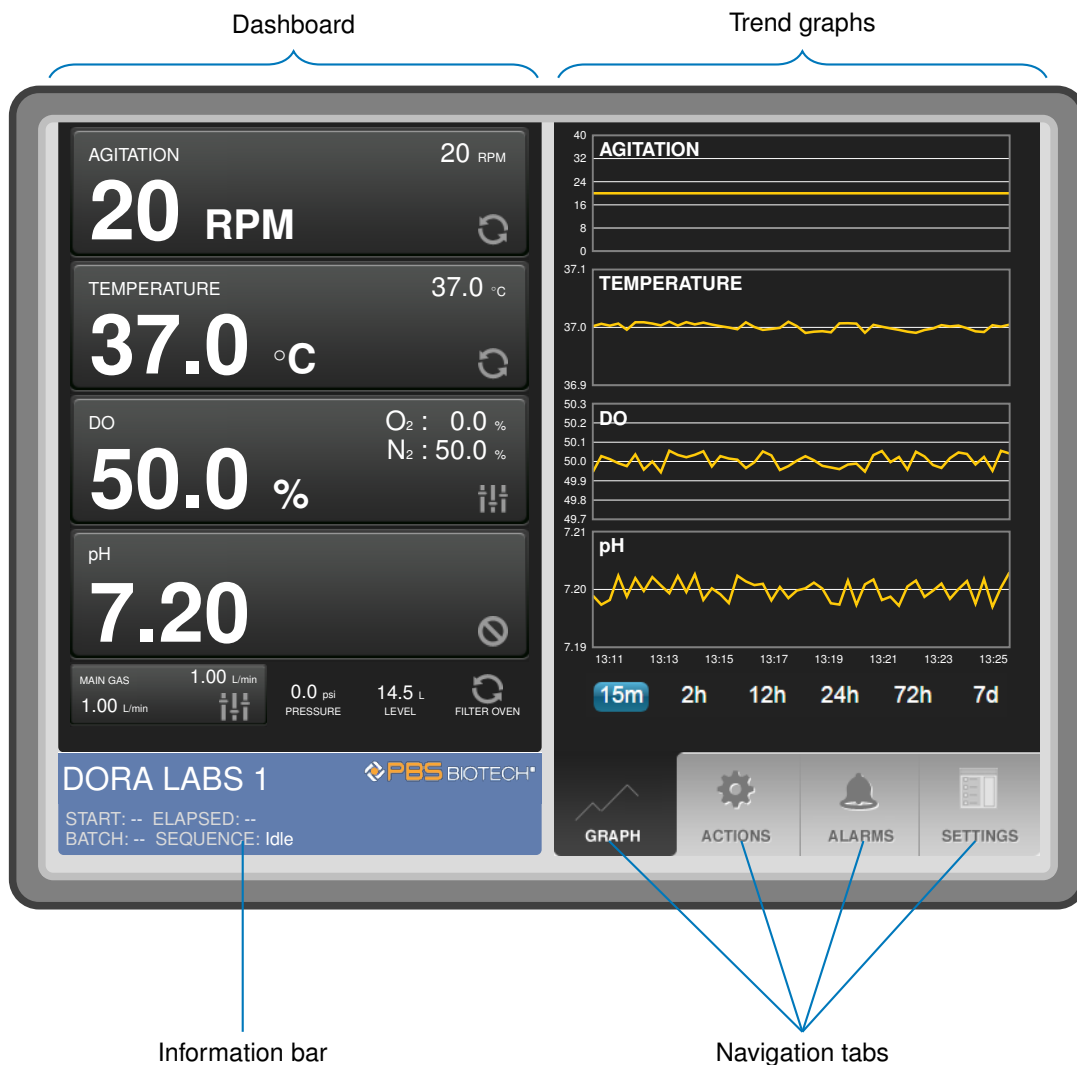

The definitions of all parts are the same as the corresponding parts of the PBS-15 (see “PBS-15 Bioreactor - Accessories” on page 24).

The Hello User Interface (Hello UI) opens automatically when the PBS-15/80 is powered on. It is the primary way of interacting with the PBS-15/80. Google Chrome and Safari for iOS are the only browsers supported. For more information, see “Hello User Interface” on page 140.



Dashboard

Consists of the “Agitation,” “Temperature,” “Dissolved Oxygen,” “pH,” and “Main Gas” buttons, along with three boxes showing the pressure, level, and filter oven mode. The buttons show the present value, set point, and mode.

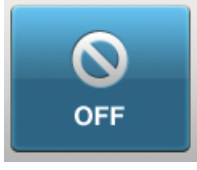
Mode Symbols	
Auto	
Manual	
Off	

Trend graphs

Show the agitation, temperature, DO, and pH PVs. The buttons below the graphs adjust the displayed time scale.

Navigation tabs

Used to navigate to view Graphs, perform Actions, view and acknowledge Alarms, and change Settings. The Alarms tab shows the number of unacknowledged alarms.

Information bar

Shows the PBS-15/80 name, the name of the current batch, the time the current batch was started, how long the current batch has been running, and the name of the recipe currently running.

The Desktop User Interface (Desktop UI) is used for performing operations the Hello UI cannot. For users, the Desktop UI will automatically launch upon startup of the PBS-15/80.

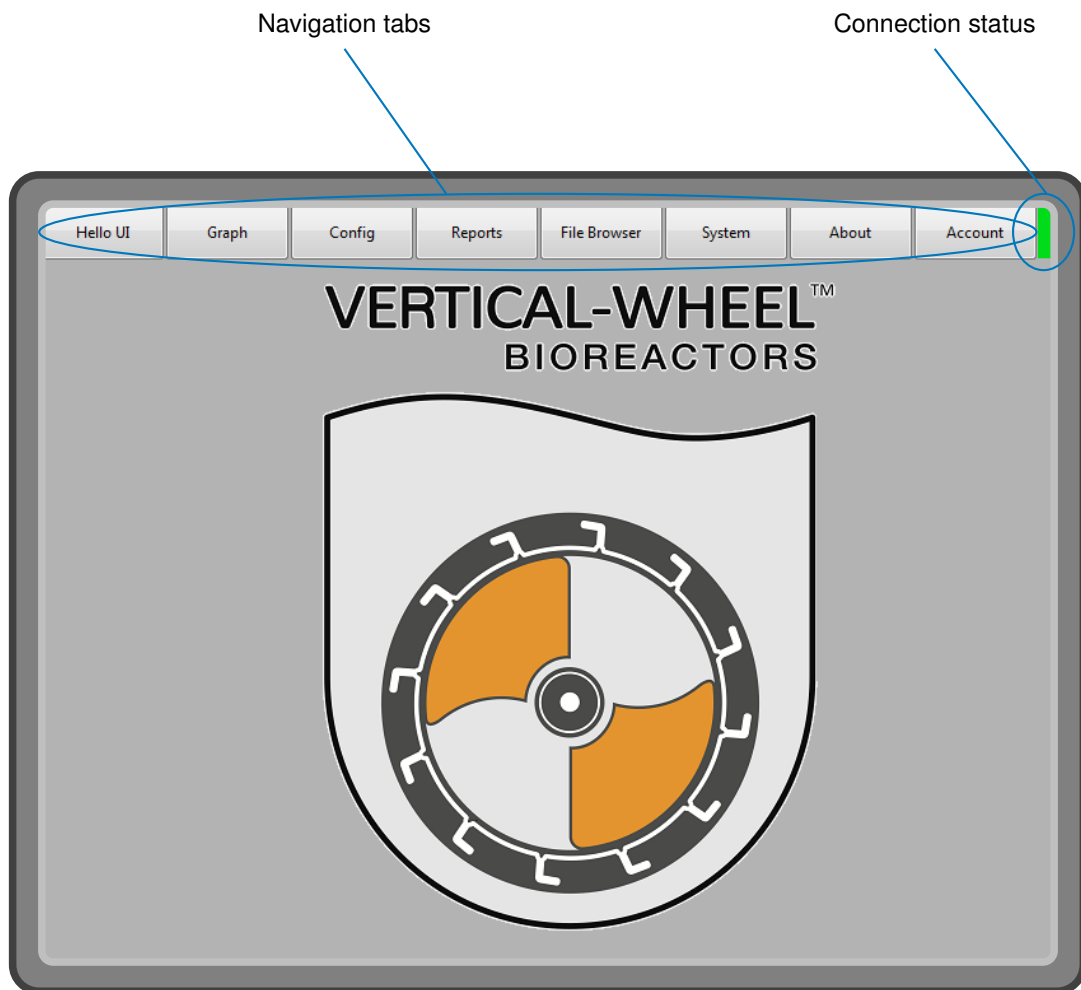

Navigation tabs

Allows users to navigate to different pages within the Desktop UI.

Hello UI

Launches the Hello UI. For more information, see “Hello User Interface” on page 140.

Graph

Accesses graphs for each of the main controls on the PBS-15/80 - Agitation, Temp, DO, pH, Level, FiltOven, Gases, and Main Gas. In the “FiltOven” submenu, users can configure the mode and set point for the filter oven. For more information on enabling and disabling the filter oven, see “Filter Oven” on page 121.

Config

Opens a drop-down menu from which users can navigate to the Alarm, Calibration, Logger, Recipe, and Settings configuration pages. For more information, see the following sections: “Configuring Logger Settings” on page 66, “Configuring Alarm Settings” on page 69, “Recipes” on page 122, “Settings/System Variables” on page 134, and “Other Calibrations” on page 139.

Reports

Allows users to generate a report for process data, user events, errors, alarms, and recipe steps for individual batches, or a specified amount of time.

File browser

Allows users to archive the current database, delete a report or archived database, copy files to a thumb drive, and configure the automatic backup feature.

System

Opens a drop-down menu in which users can configure the PBS-15/80’s name, reboot the RIO, sync the RIO’s time, and test the alarm buzzer by selecting “Tools,” or shut down, reboot, or log out of the HMI computer by selecting “Power.”

About

Displays the current system and bag information, as well as the PBS-15/80’s database history.

Account

Opens a drop-down menu, which allows users to either manage users and groups by selecting “Account,” or log out of the PBS-15/80 by selecting “Logout.”

Connection status

Indicates the status of the connection between the HMI computer and the RIO. The light is green when there are no communication issues, and turns red when there is a communication problem.

This chapter gives an overview of the PBS-15/80 Bioreactor System. It describes the high-level components and functionality of the PBS-15/80 and explains the principles of basic operation.

System Description

The PBS-15/80 Vertical-Wheel® Bioreactor System (PBS-15/80) is a single-use bioreactor intended primarily for the culture of mammalian cells and the production of cell-derived biologicals. It consists of a non-disposable PBS-15/80 Bioreactor and a Vertical-Wheel® Bioreactor Single-Use Bag Assembly (bag). The PBS-15/80 Bioreactor and bag are designed to interface closely with each other and to function as an integrated system.

This PBS-15/80 Vertical-Wheel® Bioreactor System provides all of the necessary process measurement and control features to ensure necessary conditions for the successful cultivation of cells. The PBS-15/80 consists of: an interface for the bag; an industrial controller; a four-gas module; a bag heater; a bag temperature sensor; DO and pH sensor heads; a level sensor; a pressure sensor; sampling, medium, and addition pumps; a touchscreen interface; and an exhaust filter oven. It is able to control all critical cell culture parameters, such as agitation, temperature, DO, and pH.

The Vertical-Wheel® Bioreactor Single-Use Bag is a uniquely shaped rectangular bag with a round bottom incorporating the Vertical-Wheel® impeller, which has side paddles, vanes, and a hub. The bag's shape is designed to work with the vertical impeller to offer excellent mixing and homogeneous particle suspension with very low shear stress using minimal power input.

Principles of Operation

Agitation

The PBS-15/80 falls into the category of stirred bioreactors. The biggest difference between PBS Biotech's Vertical-Wheel® Bioreactors and traditional stirred bioreactors, whether single-use or reusable, lies in the unique bag and impeller geometry, described above. The Vertical-Wheel® impeller is driven by a magnetically-coupled external motor.

Heating

The PBS-15/80 has two permanently-mounted temperature sensors in the back of the chamber which sense the temperature of the bag contents. The PBS-15/80 also has permanently-mounted electric heaters positioned beneath the chamber, which contact the bottom surface of the bag.

Dissolved Oxygen

The dissolved oxygen is monitored by a reusable DO sensor. The reusable sensors are intended to be calibrated with the PBS-15/80, autoclaved, and installed aseptically in the bag during bag installation. The PBS-15/80 controls the DO by using a two-sided PID (proportional-integral-derivative) controller. To decrease DO levels, the software increases the percent composition of N₂ flowing out of the Main-gas connector, through the Main-gas line, and into the overlay. To increase DO levels, the software flows O₂ through the Main-gas line into the overlay, or through the Micro-gas line to be sparged through the medium (depending on how the O₂ flow valve is configured).

pH

The culture pH is monitored by a reusable pH sensor. The reusable sensors are intended to be calibrated with the PBS-15/80, autoclaved, and installed aseptically in the bag during bag installation. pH is usually regulated exclusively by CO₂%, and base should only be added if absolutely necessary. The PBS-15/80 controls the pH by using a two-sided PID controller. To decrease the pH, the software increases the percent composition of CO₂ flowing out of the Main-gas connector, through the Main-gas line, and into the overlay. To increase pH, the software increases the duty of an addition pump that the user has selected to be the base pump, and supplied with a source of base.

Level

The PBS-15/80 has a built-in sensor that monitors how much pressure is necessary to push a very low gas flow from the bottom of the bag. The software converts this pressure to a height, and using the geometry of the chamber, converts the height to a volume.

Filter Oven and Condenser Bag

As sterile gas flows into the bag, it must also leave to prevent the bag from over-pressurizing. Each bag has an exhaust tubing line for this purpose. The exhaust tubing line has an in-line filter to maintain the sterility of the bag contents. To prevent clogging of the exhaust filter, each bag is equipped with a condenser bag on the exhaust tubing to catch entrained medium droplets, and

the PBS-15/80 has a temperature controlled oven to house the exhaust filter and prevent condensation of water vapor on the filter.

Pressure

The PBS-15/80 has a built-in sensor to measure the pressure in the overlay of the Vertical-Wheel® Bioreactor bag.

Overview of PBS Software Functionality and Architecture

Functionality

The PBS Software that is an integral part of your PBS-15/80 is multifunctional. Its capabilities can be grouped in the following categories:

- Sensing and Control
- Data Acquisition and Reporting
- Process and Failure Alarms
- Task Automation
- Remote Monitoring and Control
- Administration

Sensing and Control

The PBS-15/80 has the ability to monitor and control agitation, temperature, dissolved oxygen, and pH in the bag. It can also control the filter oven at a pre-determined temperature, as well as monitor the volume of the bag contents and monitor the pressure of the bag headspace. The four main control loops (agitation, temperature, DO, and pH) each have three user-selectable modes: Automatic, Manual, and Off. The main gas controller, which must be on for the DO and pH controls to function, only has a Manual and Off mode. In Automatic mode, the control loops implement PID feedback control with a set point determined by the user. In Manual mode, the control loops implement an open loop scheme where the user directly selects controller output. In Off mode, the controller's output is set to zero.

Also falling under the scope of Sensing and Control are interlocks, broken sensor detection, and broken sensor modes. The purpose of the interlocks is to prevent the creation of unsafe conditions or conditions that would hinder the growth of cells. The purpose of the broken sensor detection and mode features is to minimize the problems that could arise due to sensor failure.

Data Acquisition and Reporting

The PBS Software has the ability to collect and report multiple types of data. Data types include Process Data, User Events, Alarms, Recipe Steps, and Errors. All these data types are stored to a database on the HMI computer's hard drive (see "Architecture" on page 44), and can be exported via email or web-link to remotely connected computers as .csv (comma-separated value) files. Process data includes over 300 variables. For each Process data variable, the user can select whether or not to log them, as well as how frequently to log them. The other data types always get logged to the database.

Process and Failure Alarms

To assist you in monitoring the performance of the PBS-15/80, a comprehensive set of parameters is continuously monitored. If any parameter falls outside of a pre-defined range, an alarm event will be generated and communicated to you. Process alarms monitor your process variables, while Failure alarms monitor the PBS-15/80's sensors and other hardware.

Each alarm can be individually configured to be displayed, made to sound a buzzer, emailed, or ignored. The sensitivity of the failure alarms can be configured by the user. In addition, the process alarm limits are entirely selectable by the user according to their particular process conditions.

Task Automation

Clicking "Auto Pilot" from the "Actions" tab brings you to the menu used to activate the recipe engine.

The recipe engine allows the user to automatically run sequences of instructions on the PBS-15/80. The recipes are programmed using the Recipe Editor available in the Desktop UI. Once saved, the recipes are available to be run from the Hello UI. Recipes can be used for a variety of tasks, such as setting all the controller modes and set points at once, or for changing a set point at some time in the future when no user will be present.

Remote Monitoring and Control

The Hello UI is programmed as a web page and viewed with a web browser. The PBS-15/80 has a built-in web server that serves up the interface and handles two-way communications to and from the user. This architecture makes it easy for the user to open remote instances of the Hello UI by navigating their browser to the Hello UI server on the PBS-15/80. Multiple instances of the Hello UI can be opened simultaneously, although care should be taken to limit these remote instances to only one per device. These remote

interfaces can be opened not only on remote computers, but also on mobile devices, such as the iPhone or iPad.

Administration

In addition to all of the above, the software allows the user to perform additional direct control functions, such as turning pumps on and off. It also offers the user administrative capabilities to add user accounts, configure user permissions, and configure system variables.

Architecture

The Vertical-Wheel[®] Bioreactor control system is a hybrid consisting of an industrial automation controller (the RIO controller) paired with a human machine interface computer (HMI).









The RIO is in charge of all sensing and control functions, including interlocks, broken sensor detection, and running recipes. If the HMI were to fail (from a software crash or hardware failure), the control loops, interlocks, and recipes would continue as normal and maintain current operating conditions.







The RIO is also in charge of the logic that captures the data points to be recorded, whereas the database engine and the database are on the HMI. If the HMI were to fail, data logging would stop, and would resume when the database engine resumed operation.

Finally, the RIO is in charge of detecting process and failure alarms, and the HMI communicates those alarms to the user. Alarm notifications would cease if the HMI were not to run.

NOTICE Users should not install additional software on the HMI without first consulting PBS Biotech Technical Support.

Review the following safety information before installing the system.

	<p>The PBS-15 is intended for bench-top use. Ensure that the selected work surface has sufficient strength to safely carry the weight of the equipment plus any accessories and process materials.</p>
	<p>Customer-provided safety-straps may be used to reduce the risk of tipping or damage in the event of earthquake. Do not drill into the equipment or use screws to attach straps. Industrial-strength self-adhesive straps may be affixed to the metal sides of the system.</p>
	<p>If any PBS Biotech equipment is used with accessories not provided or recommended by PBS Biotech or used in a manner not specified by PBS Biotech, the protection provided by the equipment may be impaired.</p>
	<p>The power cord is the main electrical disconnect for the equipment. To remove power from the equipment, unplug the power cord. Do not position the equipment in such a way that it is difficult to unplug the power cord. Do not apply tension on the power cord, to avoid sudden electrical disconnects.</p>
	<p>To provide continued protection against risk of electric shock, the equipment must be connected to a properly grounded outlet. Only use power cords provided by PBS Biotech. Do not use an adapter.</p>
	<p>The back panel of the equipment must only be removed by a trained technician. High voltage circuits are accessible inside and there is a danger of lethal electric shock.</p>
	<p>Use caution when working near peristaltic pumps. Keep fingers, jewelry, loose clothing, etc. free of the rotating pumps to prevent injury.</p>
	<p>The PBS-15/80 has hot surfaces, as indicated by hot surface warning signs. Do not touch hot surfaces.</p>

	Vertical-Wheel® Bioreactors are not designed for pressurized operation. Always allow the bioreactor bag to vent. Never clamp the bag outlet lines. This could result in dangerous pressure build-up in the bag.
	Only use bags manufactured by PBS Biotech for the specific model of your bioreactor system.
	Pumps may restart automatically if the power is restored after an interruption.
	When using external pumps to fill a bag installed in the bioreactor, use precautions to ensure that the bag will not overflow, which could cause dangerous pressure build-up.
	Biological substances, such as viruses, cells, and sera, have the potential to transmit infectious diseases. If biohazardous materials are used with this equipment, follow all applicable local, state/provincial, and/or national regulations, including identification of samples with the biohazard symbol. Wear appropriate protective eyewear, clothing, and gloves.
	If the equipment has been used in a biohazardous environment, it must be decontaminated according to all applicable local, state/provincial, and/or national regulations prior to any shipment, or disposal.
	Customers are to follow local regulatory guidelines for proper recycling and disposal of PBS products.

Supplier's Declaration of Conformity (USA)

FCC / 47 CFR § 2.1077 Compliance Information

Identification of Product: PBS 15

Responsible Party: PBS Biotech, Inc.
4721 Calle Carga
Camarillo, CA 93012 USA
1 (805) 482-7272

This device complies with Part 15 of the FCC Rules. Operation is subject to the following two conditions:

- (1) This device may not cause harmful interference, and
- (2) this device must accept any interference received, including interference that may cause undesired operation.

NOTICE The PBS 15 has been tested and found to comply with the limits for a Class A digital device, pursuant to part 15 of the FCC Rules. These limits are designed to provide reasonable protection against harmful interference when the equipment is operated in a commercial environment. This equipment generates, uses, and can radiate radio frequency energy and, if not installed and used in accordance with the instruction manual, may cause harmful interference to radio communications. Operation of this equipment in a residential area is likely to cause harmful interference in which case the user will be required to correct the interference at his own expense.

Inspections and Preventative Maintenance

Inspections

This section describes the inspections that the user should perform on the PBS-15/80 Bioreactor system to verify safety mechanisms are functional. For instructions on inspecting a Vertical-Wheel® Bioreactor bag before use, see “Integrity Test” on page 92.

Drip Tray

Confirm that a drip collection container is properly connected to the drip collection line, to catch liquid in the event of spills.

Leak Sensor

Drip a small amount of water onto the leak sensor. The LED should change from green to amber. Dry off its contacts, and it should change back to green. If the “active” Alarms.alm file is configured correctly, the buzzer will sound when the leak sensor’s contacts are wet. For more information, see “Configuring Alarm Settings” on page 69.

Door Lock

Attempt to open the door without using the software or manually overriding the door latch. This confirms that the door latch works, and that the door can only open if the user unlocks it through the software, or manually overrides it.

Safety-Related Settings

Confirm that all settings in the “Safety” group match those listed in Appendix 1 on page 208, or that the values have been confirmed with PBS Biotech Technical Support. Do not attempt to verify the functionality of any interlocks - that should only be performed by a representative of PBS Biotech.

Comb Plate

Confirm that nothing is resting on top of the comb plate, as this would prevent the bag from pushing the comb plate up if the bag became over pressurized. The functionality of the kill switch beneath the comb plate may be verified by lifting the comb plate away from the magnets holding it in place. Restore the comb plate to its original position after confirming that the MFCs and pumps will not operate.

The pressure at which the comb plate is pushed up should only be verified by a representative of PBS Biotech.

Preventative Maintenance

To keep your PBS-15/80 properly maintained, clean and decontaminate it after each run (see below). For other maintenance on the PBS-15/80, contact PBS Biotech Technical Support.

Cleaning and Decontamination

To clean and decontaminate the PBS-15/80, use 70% IPA or EtOH. Apply the cleaning solution to a clean, soft cloth - do not spray or apply cleaning solution directly onto the PBS-15/80. Wipe down all surfaces of the PBS-15/80, including inside the bag chamber and drip collection tray. Be very gentle when cleaning the temperature sensors and level sensor. If a leak occurred, flush the drip collection line and decontaminate or replace the contaminated components of the liquid containment system it leads to. Contact the manufacturers of other equipment in use, such as a keyboard or Uninterruptible Power Supply (UPS), for cleaning and decontamination instructions.

NOTICE Do not use abrasive materials on the PBS-15/80. It is the user's responsibility to avoid use of decontamination or cleaning agents that could cause a hazard as a result of a reaction with parts of the equipment or material contained in it. Contact PBS Biotech Technical Support if there is any doubt about the compatibility of decontamination or cleaning agents.

This protocol is appropriate to clean and decontaminate equipment in contact with materials assigned to Biosafety Level 1. In case of operation in a higher Biosafety Level facility, please contact PBS Biotech Technical Support.

Lifting and Handling

PBS-15

The PBS-15 weighs approximately 84 kg (185 lbs). To prevent injury or damage to the product, it should only be lifted by at least two individuals from the pallet onto the bench. Spotters should be present in front of and behind the bioreactor to make sure it does not tip over during lifting. Proper lifting technique of bending at the knees and lifting with the legs should be used.

PBS-80

The PBS-80 weighs approximately 223 kg (490 lbs). To prevent bodily injury and/or damage to the product, it should only be moved by at least two individuals using the built-in casters. Unlock the casters and roll the bioreactor down a ramp off the pallet and to its final destination. Avoid pushing on the monitor or door window and do not attempt to lift or carry the bioreactor.

Note: These specifications are for the standard PBS-15/80 configuration as of publication. Individual bioreactors may differ.

PBS-15/80 Specifications		
General	Size	<p>PBS-15 Width: 66 cm (26.0 inches) Depth: 42 cm (16.5 inches) Height: 90 cm (35.5 inches)</p> <p>PBS-80 Width: 93 cm (36.5 inches) Depth: 56 cm (22 inches) Height: 146 cm (57.5 inches)</p>
	Weight	<p>PBS-15: 84 kg (185 lbs) without Bag PBS-80: 223 kg (490 lbs) without Bag</p>
	Minimum Space Requirements	<p>PBS-15 Width: 87 cm (34 inches) Depth: 69 cm (27 inches) Height: 122 cm (48 inches)</p> <p>PBS-80 Width: 147 cm (58 inches) Depth: 147 cm (58 inches) Height: 168 cm (65 inches)</p>
	Electrical	6 A (max), 110-120 Vac, 50/60 Hz or 3 A (max), 200-240 Vac, 50/60 Hz, depending on model Overvoltage Category II
	Environmental Rating	Indoor use, Ambient Temperature: 16 - 32 °C (61 - 90 °F) Humidity: 10 - 80% RH Altitude: 2,000 m (6,500 ft) max Pollution Degree: 2

PBS-15/80 Specifications		
Bioreactor Geometry	Rated Working Volume	PBS-15: 15 L PBS-80: 80 L
	Minimum Working Volume	PBS-15: 9 L (top of wheel) PBS-80: 45 L (top of wheel)
	Impeller Type	Vertical-Wheel® mixing technology
Controls	Control Interface	Integrated 8.4" (PBS-15) or 10.4" (PBS-80) touch screen. Network connectivity capability.
	Control Hardware/Software	Industrial embedded real-time control
	Data Communication	Built-in data historian, remote control panel accessible over Ethernet
	Data Connection Ports	2x USB 2.0 1x RJ45 Ethernet
Agitation	Agitation Mechanism	Brushless DC motor drive, Magnetic coupling to bag impeller
	Agitation Control Range (Accuracy)	PBS-15: 5 – 50 RPM (± 1 RPM) PBS-80: 2 – 34 RPM (± 1 RPM)
	Agitation Sensor Type	Hall effect (magnetic sensing)
Gassing	Gassing Mode	Headspace overlay with an optional sparger
	Gas Control	4 mass flow controllers (for Air, N ₂ , O ₂ , CO ₂ gases) Manual control of total gas flow rate Individual gas outputs as determined by Dissolved Oxygen and pH controls

PBS-15/80 Specifications		
Gassing (continued)	Gas Flow Rate Range	PBS-15 100 – 2,000 mL/min for Air, N ₂ 30 – 500 mL/min for O ₂ 30 – 300 mL/min for CO ₂
		PBS-80 300 – 10,000 mL/min for Air, N ₂ , O ₂ 80 – 2,000 mL/min for CO ₂
Temperature	Temperature Control Range (Accuracy)	5 °C above ambient to 40 °C (± 0.5 °C)
	Temperature Sensor Type	Dual (redundant) Class A Platinum RTD
Dissolved Oxygen	DO Control	Two-sided PID control with N ₂ and O ₂ or manual control
	DO Sensor Type	Broadley James OxyProbe® polarographic
pH	pH Control	Two-sided PID control with CO ₂ and base addition pump or manual control
	pH Sensor Type	Broadley James FermProbe® electrochemical
Level	Level Sensor Type	Pressure differential via precision industrial pressure sensor
Pressure	Pressure Sensor Type	Precision industrial pressure sensor

PBS-15/80 Specifications		
Pumps	Media pump	Watson Marlow 313D Series Unidirectional, Variable-Speed, 400 RPM max. continuous speed
	Addition pump A	PBS-15 Watson Marlow 114DV Series Unidirectional, 3-Speed, 200 RPM max. continuous speed
		PBS-80 Watson Marlow 313D Series Unidirectional, Variable-Speed, 400 RPM max. continuous speed
	Addition pump B	Watson Marlow 114DV Series Unidirectional, 3-Speed, 200 RPM max. continuous speed
	Sample	Watson Marlow 114DV Series Bidirectional, Single-Speed, 100 RPM
Single-Use Bag	Bag Construction	Polyvinylidene fluoride (PVDF)
	Impeller Construction	Injection-molded polycarbonate
	Product Contact Materials	All product contact materials meet requirements for USP Class VI Testing for Plastics <88> and/or ISO 10993
	Gamma Radiation Absorbed Dose	25 – 40 kGy
	Media and Addition Lines	Silicone and C-Flex®
	Exhaust Line	Platinum-cured silicone tubing with condenser bag and 0.2-micron exhaust filter
	Main-Gas Line	Platinum-cured silicone tubing with 0.2-micron filter

PBS-15/80 Specifications		
Single-Use Bag (continued)	Micro-Gas Line	Platinum-cured silicone tubing with 0.2-micron filter
	Sampling Line	Platinum-cured silicone and C-Flex [®] tubing with syringe, 3-way valve and 0.2-micron filter
	Harvest Line	Variable-height sampling port. Polycarbonate, Platinum-cured silicone and C-Flex [®]
	Level-Sensing Line	Platinum-cured silicone tubing with 0.2-micron filter
Service Life	Mechanical Drive Belt	Expected Service Life 1 year minimum
	Mechanical Drive Components (excepting belt)	Expected Service Life 3 year minimum
Safety and Regulatory	Markings (housing)	PBS-15: NRTL (NEMKO), CE PBS-80: N/A

FermProbe[®] is a registered trademark of Broadley-James Corporation.
 OxyProbe[®] is a registered trademark of Broadley-James Corporation.
 C-FLEX[®] is a registered trademark of Saint-Gobain Performance Plastics Corporation.

This chapter gives detailed instructions on how to install the PBS-15/80.

Integrated Bioreactor

Minimum Space Requirements

Before you begin, see “Minimum Space Requirements” on page 50 and confirm that your available bench space (for the PBS-15) or floor space (for the PBS-80) meets or exceeds the minimum space requirements listed.

Utility Requirements

General Electrical Requirements

- Outlets must be properly grounded.
- The power cord must be provided by PBS Biotech, Inc.

For other electrical requirements, see “Electrical” on page 50, and the Safety information in Chapter 3 starting on page 45.

General Gas Requirements

- The gases supplied must be clean, dry, particulate-free, and oil-free to prevent MFC damage from contaminated gases.
- All gases must be connected to their corresponding gas connector inlets on the gas connection panel unless instructed otherwise by PBS Biotech Technical Support.

Gas Tubing Outer Diameter

Depending on the bioreactor’s configuration, it will require one of the following tubing sizes for all gases:

- 1/4 inch OD tubing
- 6 mm OD tubing

Gas Tubing Material

The following materials (or equivalent) are appropriate for the gas tubing:

- Polyethylene
- Polyurethane

NOTICE The gas connectors on the back of the bioreactor are push-to-connect connectors. Disconnecting the tubing requires pushing in the orange or gray connector, then pulling out the tubing. Improper removal of tubing can break the retaining clip and impact the holding capability/seal when tubing is reinstalled.

Gas Supply Pressures

Note: To ensure proper operation, gases must be regulated near the bioreactor system to a consistent pressure within the ranges specified below. Fluctuating inlet gas pressure may cause MFC flow rates to become unstable.

PBS-15

Gas	Imperial	Metric
Air, O ₂ , N ₂	20 – 40 psig	140 – 275 kPa
CO ₂	14 – 16 psig	96.5 – 110 kPa

PBS-80

Gas	Imperial	Metric
Air, CO ₂ , O ₂ , N ₂	25 – 40 psig	175 – 275 kPa

Unit Placement

To prevent bodily injury and/or damage to the product(s), see “Lifting and Handling” on page 49 and follow the safety instructions.

PBS-15

The unit should be placed on a tabletop or benchtop where the appropriate utilities have been prepared.

Once the unit is in place, the utilities and liquid containment system may be connected.

PBS-80

The PBS-80 should be placed in a clear floor space where the appropriate utilities have been prepared, and its casters should be locked. At that point, the utilities and liquid containment system may be connected.

Connecting the Drip Collection Line

The drip collection line is located behind the bioreactor. It must be attached to tubing with an internal diameter of 1.27 cm (0.50 in) for PBS-15, or 1.91 cm (0.75 in) for PBS-80. The tubing should lead to a container below the bioreactor to allow overflow from the bag to drain through the line by gravity.

Powering On the PBS-15/80

Install the appropriate power cord on the PBS-15/80. It is recommended to plug it into an Uninterruptible Power Supply (UPS), to allow control to be maintained in the event of a power failure. A grounded outlet is required. The PBS-15/80 will automatically power on, and the Hello UI will automatically load once the system has finished booting.

Configuring Users and Groups

Both the Hello UI and the Desktop UI require a user to log in before making any changes. This section describes how to create new users and modify user accounts.

The PBS-15/80 comes with two default user accounts for you to start with:

Username: user1
Password: 12345
Permissions: All but "Account Management"

Username: admin
Password: 12345
Permissions: None but "Account Management"

The PBS-15/80 also comes with a user account "pbstech," which will be used by PBS Biotech Technical Support if they need to log in to your bioreactor system. This is the only account in the "pbstech" user group. Do not delete or change this account or user group, and do not add other users to the user group.

PBS Biotech Technical Support strongly suggests changing the username and password for the user1 and admin accounts to make them more secure, and

adding accounts with unique usernames and passwords for each individual accessing the bioreactor system.

While all usernames and passwords should be as secure as possible, it is particularly important to change the admin account username and password to something that is difficult to guess in order to prevent malicious users from accessing that account to give themselves extra permissions they are not authorized to have.

In order to prevent users from being permanently locked out of their bioreactor, the PBS Software prohibits password expiration for user groups with the Account Management permission, and users within these user groups (i.e. Account Managers) cannot be locked out after multiple failed login attempts. For security purposes, the usernames associated with these user groups should remain unknown to all other users. To ensure these usernames remain unknown, PBS Biotech Technical Support recommends disabling the “Hello Access” permission for all user groups with the “Account Management” permission to prevent the associated usernames from appearing on the Hello UI login screen, which is accessible to anyone with physical or remote access to the bioreactor.

Creating a New User Group

1. Log in to the Desktop UI using the user name and password of an account in a group with the “Account Management” permission.
2. Click “Account” and then “Manage.”

3. Navigate to the “Configure Groups” tab.

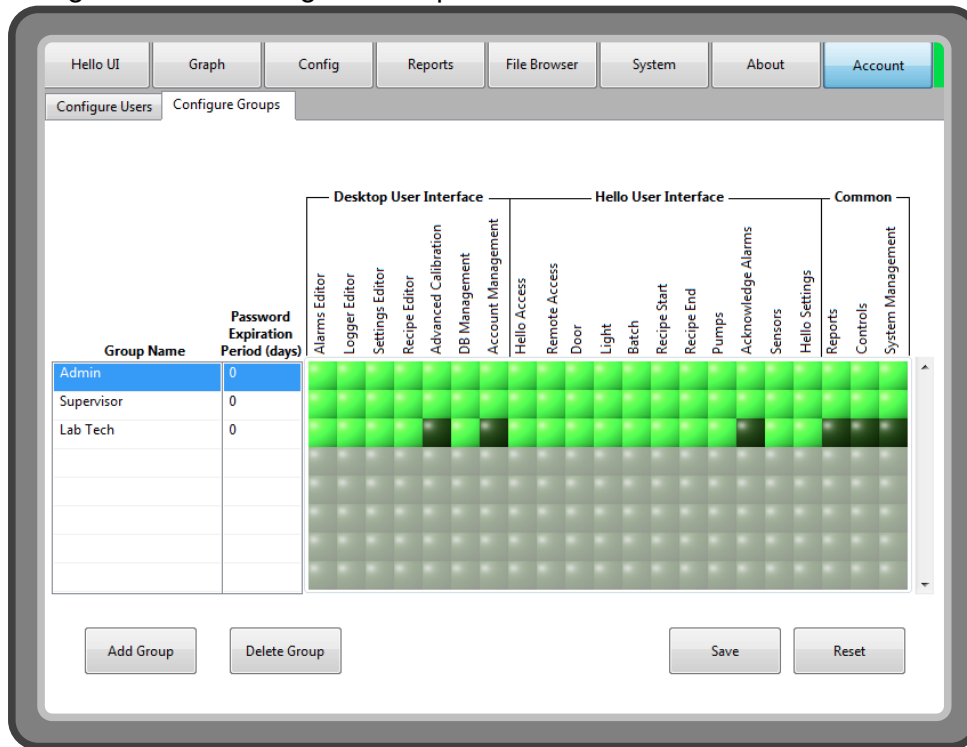

4. Click “Add Group” and enter a name using the on-screen keyboard or an external keyboard. Groups with blank names cannot be saved. Click “Enter.”

Editing Group Permissions

Group permissions are divided into three categories: Desktop User Interface, Hello User Interface, and Common. To edit the permissions of a group, simply select the green square corresponding to the permission you wish to edit. Bright green indicates that the permission is granted, dark green indicates that the user group does not have that permission. For more information on group permissions, see “User Group Permissions” on page 176.

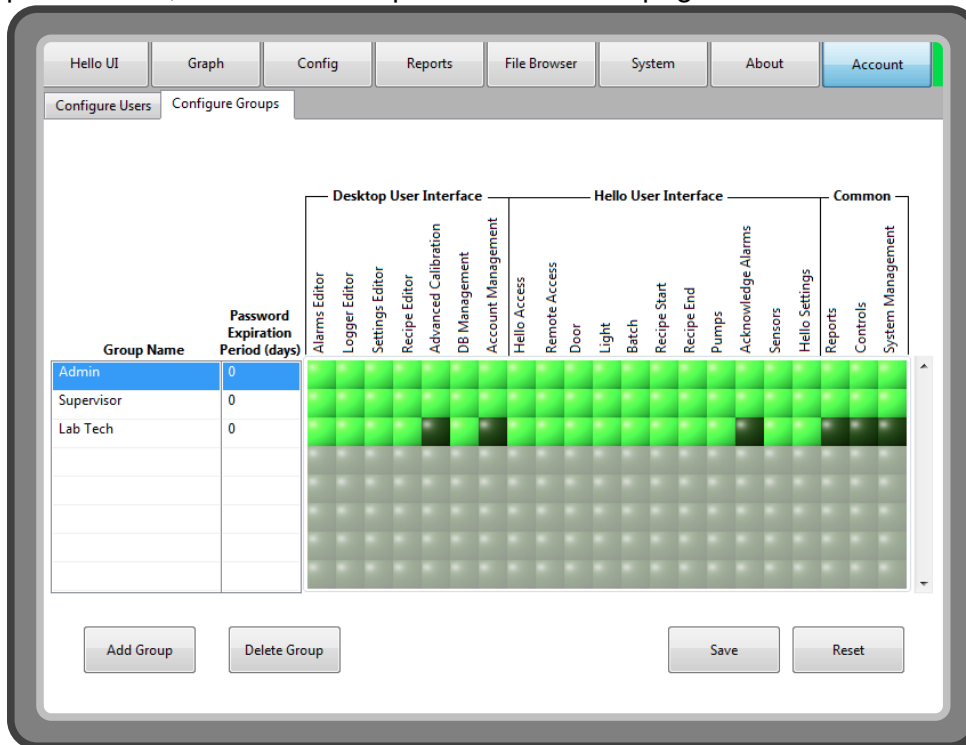

Editing Group Password Settings

The default time period for password expiration is “0,” which means the password will never expire. To edit this value, double click the “Password Expiration Period (days)” box that corresponds to the Group Name. The Group Name can also be edited in this way.

Creating a New User

1. Navigate to the “Configure Users” tab.

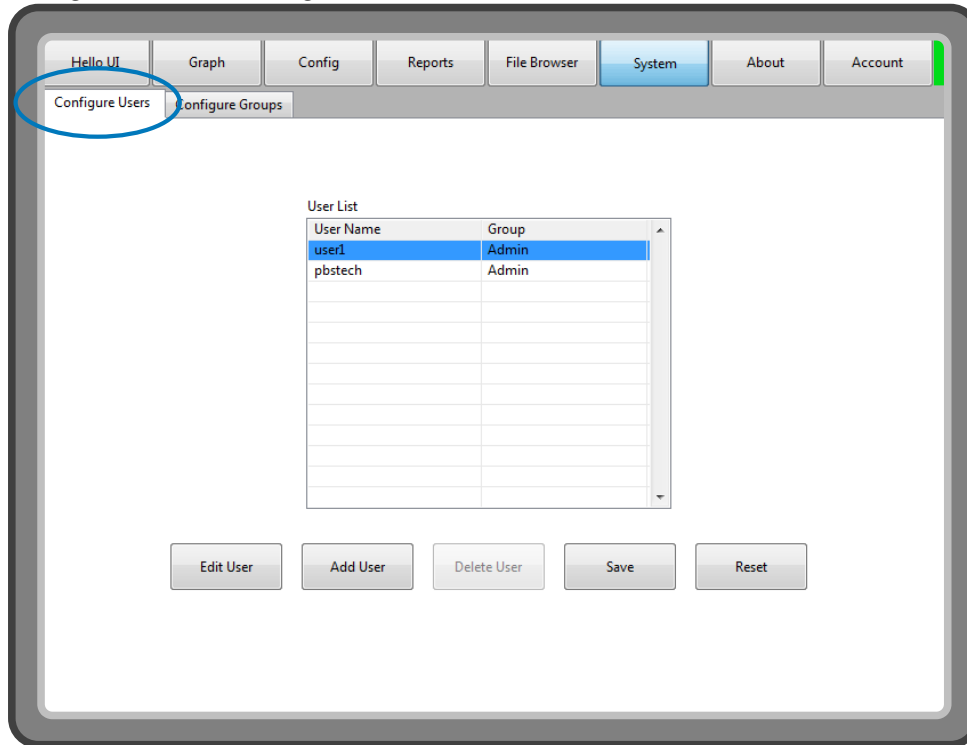

2. Click “Add User,” and the “Edit User” screen will appear.

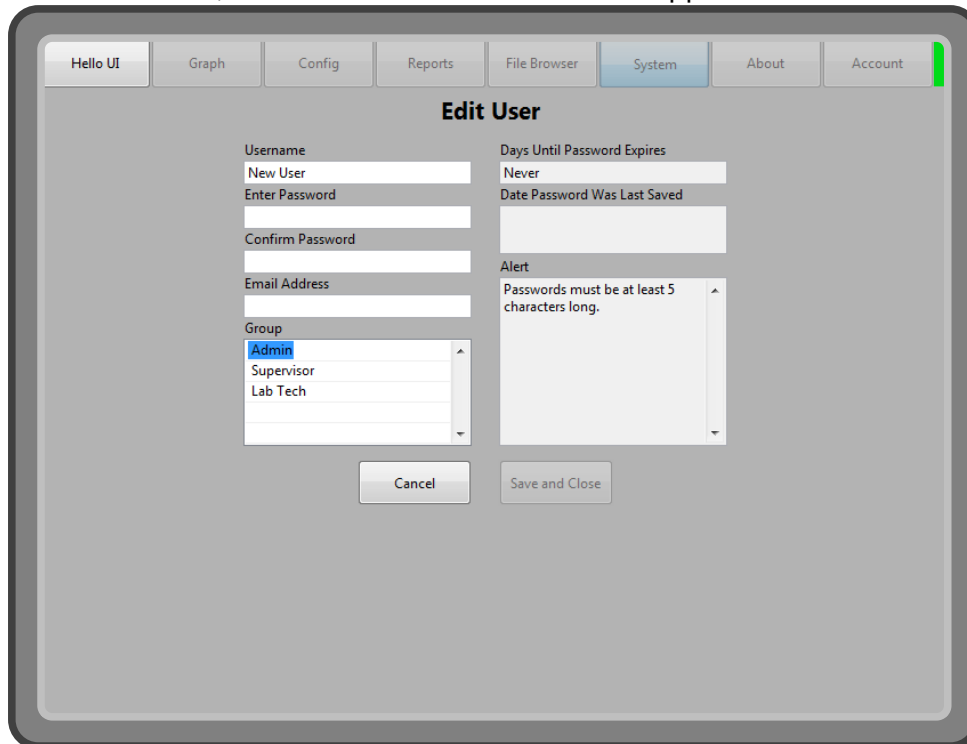

3. To change the name from the default “New User,” click the text field under

“Username” and use the on-screen keyboard or an external keyboard to enter a new name, then click “Enter.” Usernames must be unique, cannot be blank, and cannot contain capital letters, spaces, or symbols.

4. To enter a password, select the “Enter Password” field and enter the new password, then click “Enter.” When entering a password for an account in a group with the “Hello Access” permission, use only numbers. Do not use any letters, spaces, or symbols. Passwords must be at least 5 characters long, and have no maximum length. Users who desire more stringent password requirements may implement their own internal policies, which will not be enforced by the software.
5. (Optional) To link an email address to the user, click the “Email Address” field and enter a valid email address. The account’s email address is used to send alerts about failed login attempts and to email reports generated in the Hello UI.
6. Select the user group that the user will be assigned to from the “Group” field.
7. The “Days Until Password Expires” field will reflect the “Password Expiration Period (days)” that is associated with the user group under the “Configure Groups” tab, and cannot be edited within the “Configure Users” tab.
8. When you are finished, click “Save and Close.”

Modifying User Accounts

1. To edit a user, select the user in the “User List” section under the “Configure Users” tab, and then click “Edit.” Change the User Name, Password, Email Address, or Group. Click the “Save and Close” button to save the new user settings.
2. To delete a user, select the user in the “User List” section under the “Configure Users” tab, and click the “Delete User” button. Click the “Save” button to save these changes.
3. To edit a user group, select the group in the “Group List” section under the “Configure Groups” tab. Change the Group Name, Password Expiration Period, or Permission Options. Click the “Save” button to save any changes.
4. To delete a user group, select the group in the “Group List” section under the “Configure Groups” tab, click the “Delete Group” button, and click the “Save” button. Note that groups with users still assigned to them cannot be deleted.

Users' Own Accounts

Users without the “Account Management” permission can modify their own password (to prevent it from expiring) and their own email address. They will not be able to modify anything else in their account, or see any information about any other user account.

1. Click “Account” and then select “Manage.”

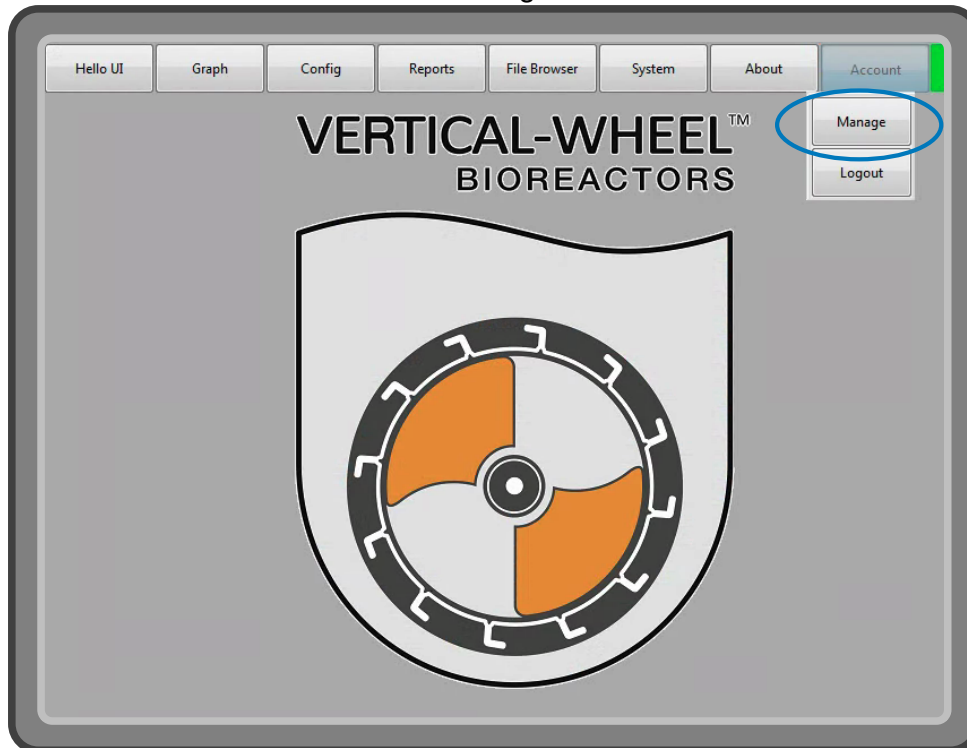

2. Make and save desired changes.

Naming the PBS-15/80

The PBS-15/80 ships with a generic name. However, PBS Biotech Technical Support suggests you change the name as you see fit.

1. Log in to the Desktop UI as a user with “System Management” permission.
2. Navigate to System → Tools.

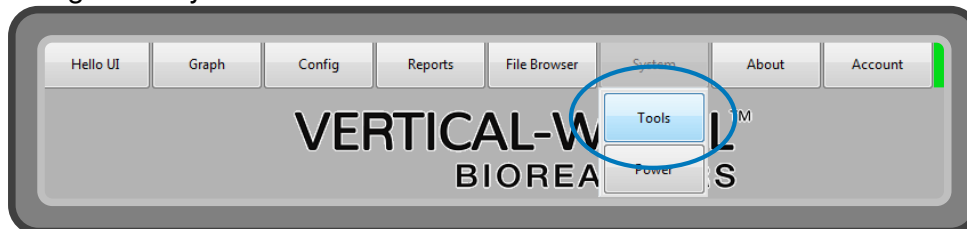

3. Under “Bioreactor Name,” select the ‘New Bioreactor Name’ field.

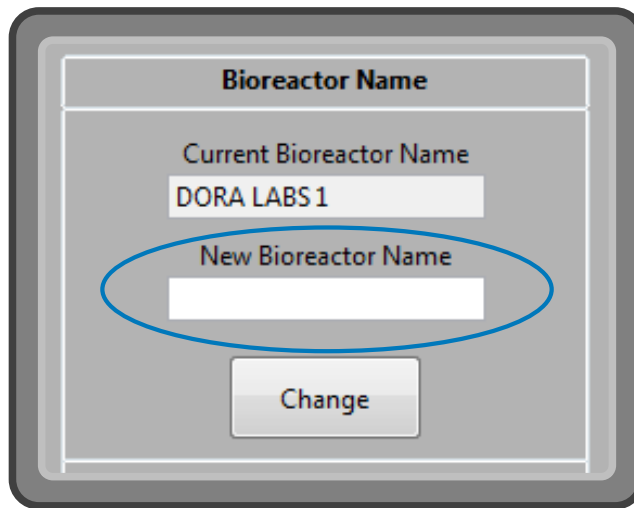

The screenshot shows a dialog box titled "Bioreactor Name". It contains two text input fields. The first field, labeled "Current Bioreactor Name", contains the text "DORA LABS 1". The second field, labeled "New Bioreactor Name", is empty and is highlighted with a blue oval. Below the fields is a button labeled "Change".

4. Enter the desired name using the on screen keyboard or an external keyboard and select “Enter.” The name you entered should now appear in the ‘New Bioreactor Name’ field.
5. Click “Change.” The ‘Current Bioreactor Name’ field should now match the ‘New Bioreactor Name’ field.

Configuring Logger Settings

Before beginning a run, you should configure what data is recorded and how often. For an in-depth explanation for how data recording works, see “Process Data Recording” on page 170.

1. Log in to the Desktop UI as a user with the “Logger Editor” permission.
2. Navigate to Config → Logger.



3. Click “Open” to edit an existing Logger Settings file, or “New” if you would like to create an entirely new Logger Settings file. You can create multiple logger settings configuration files and give them different names.

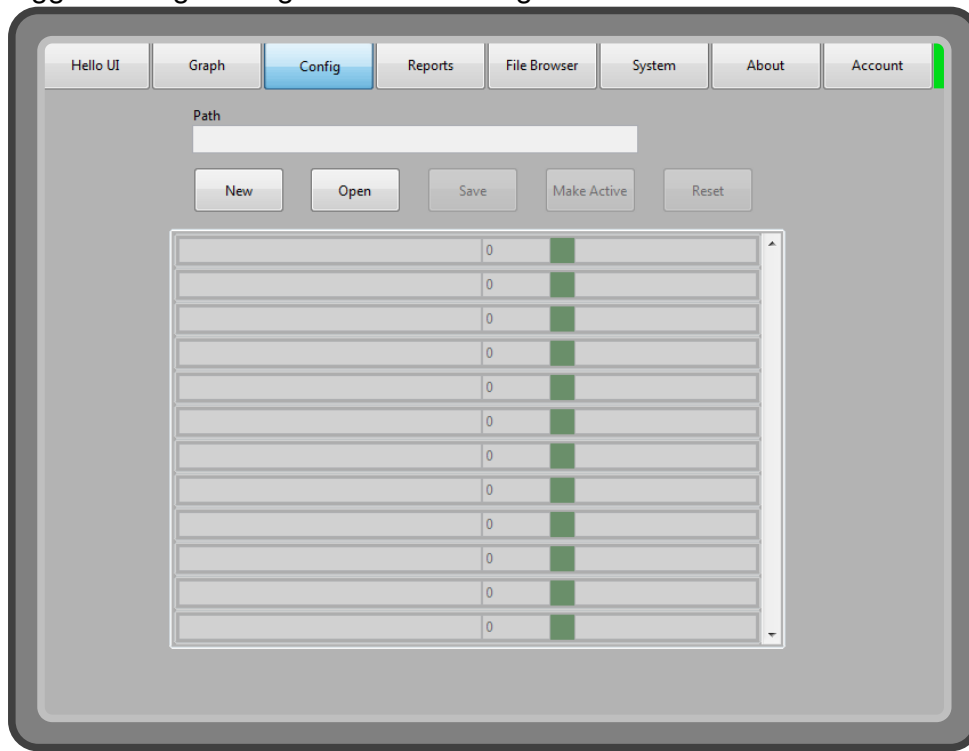

4. If opening an existing logger settings file, select the desired file in the window and click “Open.”

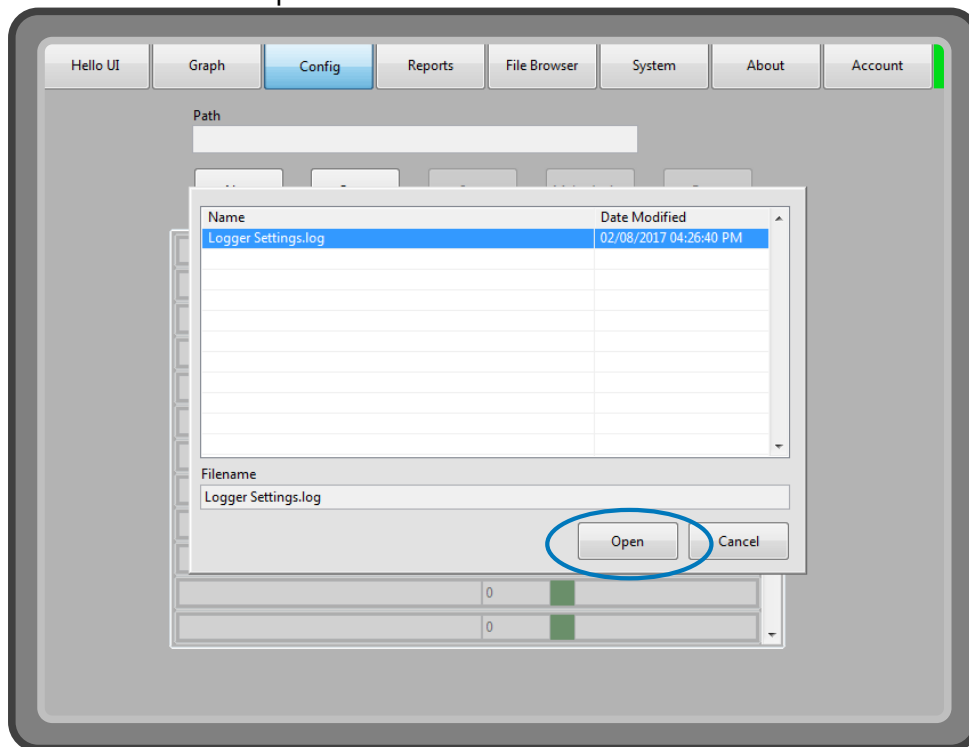

- The screen will display the variable name, the deadband value, a green box, and the group the variable belongs to.

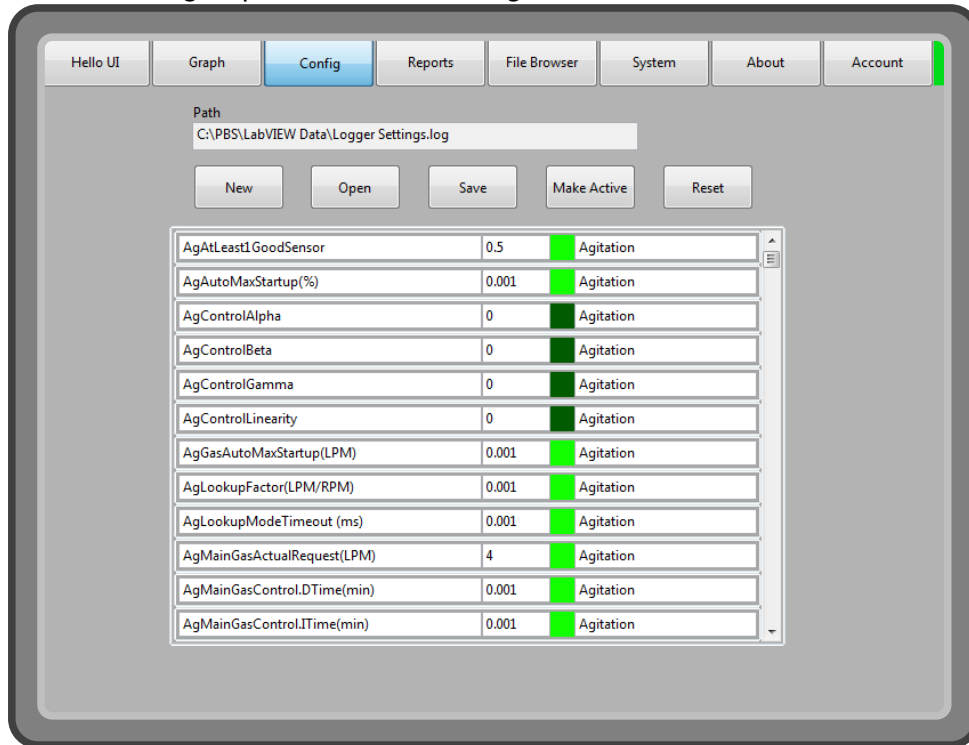

- To change the value of the deadband for a variable, click the number field next to the corresponding variable and enter the desired value using the on-screen keypad or an external keyboard.
- To change whether a variable is recorded or not, click the green square next to the deadband value. Bright green indicates that the variable will be recorded, while dark green indicates that it will not.
- If you wish to reverse changes you have made, click “Reset” and the file will revert back to its original values.
- When you are finished making your desired changes, click “Save” and either select “Save” again to overwrite the file, or change the file name to create a new one.
- Click “Make Active” to make the selected file active on the RIO.

Configuring Alarm Settings

The PBS-15/80 comes with its Alarms Off.alm file loaded so the non-run conditions will not set off any alarms (disconnected sensors, temperature far below 37 °C, etc.). You can create and edit multiple Alarms configuration files using the Alarms Editor in the Desktop UI.

Creating and Editing Alarm Files

1. Log in to the Desktop UI as a user with the “Alarms Editor” permission.
2. Navigate to Config → Alarm.



3. Click the “Open” button.

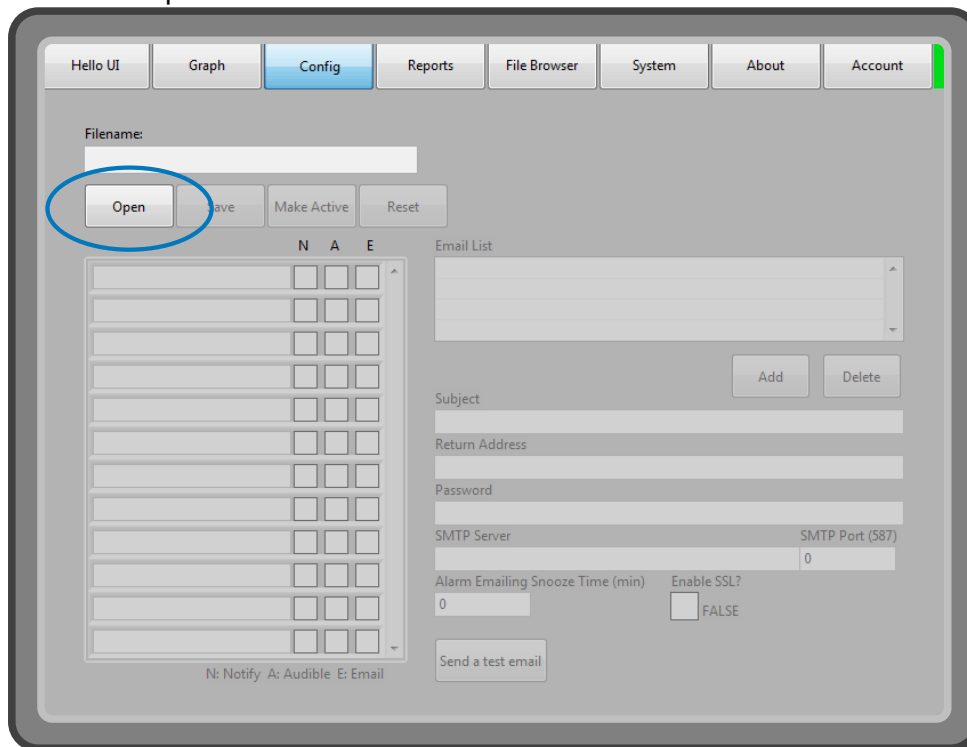

4. Select the desired Alarms.alm file in the window and click “Open.”

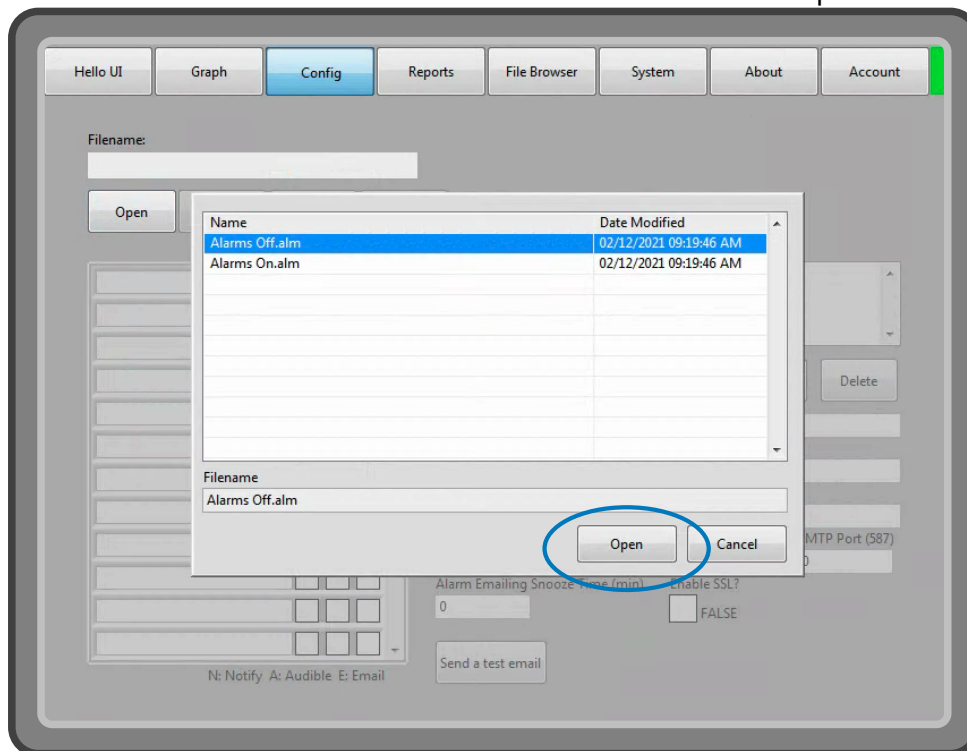

5. Configure alarms notifications by selecting “N,” “A,” and/or “E” for each alarm, where “N” is Notify (appears in the Alarms tab of the Hello UI), “A” is Audible (a buzzer sounds), and “E” is Email, where an email is sent to all of the email addresses in the “Email List” from the email address in the “Return Address” field. Note that an alarm that is not set to Notify will not sound a buzzer or be emailed, regardless of how “A” and “E” are configured.

The screenshot shows the 'Config' window of the PBS-15/80 interface. The window has a menu bar with 'Hello UI', 'Graph', 'Config' (selected), 'Reports', 'File Browser', 'System', 'About', and 'Account'. Below the menu bar, the 'Filename' field is set to 'C:\PBS\LabVIEW Data\Alarms On.alm'. There are buttons for 'Open', 'Save', 'Make Active', and 'Reset'. The main area is divided into two sections: a table for configuring individual alarms and a form for email settings.

	N	A	E
Agitation Low Low	<input checked="" type="checkbox"/>	<input checked="" type="checkbox"/>	<input checked="" type="checkbox"/>
Agitation Low	<input checked="" type="checkbox"/>	<input type="checkbox"/>	<input checked="" type="checkbox"/>
Agitation High	<input checked="" type="checkbox"/>	<input type="checkbox"/>	<input type="checkbox"/>
Agitation High High	<input checked="" type="checkbox"/>	<input checked="" type="checkbox"/>	<input type="checkbox"/>
Temperature Low Low	<input checked="" type="checkbox"/>	<input checked="" type="checkbox"/>	<input checked="" type="checkbox"/>
Temperature Low	<input checked="" type="checkbox"/>	<input type="checkbox"/>	<input checked="" type="checkbox"/>
Temperature High	<input checked="" type="checkbox"/>	<input type="checkbox"/>	<input checked="" type="checkbox"/>
Temperature High High	<input checked="" type="checkbox"/>	<input checked="" type="checkbox"/>	<input checked="" type="checkbox"/>
DO Low Low	<input checked="" type="checkbox"/>	<input checked="" type="checkbox"/>	<input type="checkbox"/>
DO Low	<input checked="" type="checkbox"/>	<input type="checkbox"/>	<input type="checkbox"/>
DO High	<input checked="" type="checkbox"/>	<input type="checkbox"/>	<input type="checkbox"/>
DO High High	<input checked="" type="checkbox"/>	<input checked="" type="checkbox"/>	<input type="checkbox"/>

Legend: N: Notify A: Audible E: Email

Email List: user1@pbscustomer.com

Buttons: Add, Delete

Subject: PBS 3 Bioreactor A

Return Address: pbs@pbscustomer.com

Password: *****

SMTP Server: smtp.office365.com SMTP Port (587): 587

Alarm Emailing Snooze Time (min): 5

Enable SSL? TRUE

Send a test email

6. Configure email notifications. The PBS-15/80 arrives with a PBS Biotech email address for sending emails. The size limit for generating and emailing files is about 10 MB, due to CPU and memory limitations. To change the PBS-15/80's sending address:

The screenshot shows a configuration window for email notifications. It features several input fields and buttons:

- Email List:** A list box containing 'user1@pbscustomer.com'. Below it are 'Add' and 'Delete' buttons.
- Subject:** A text field containing 'PBS 3 Bioreactor A'.
- Return Address:** A text field containing 'pbs@pbscustomer.com'.
- Password:** A text field containing '*****'.
- SMTP Server:** A text field containing 'smtp.office365.com'.
- SMTP Port (587):** A text field containing '587'.
- Alarm Emailing Snooze Time (min):** A text field containing '5'.
- Enable SSL?:** A checked checkbox with the text 'TRUE' next to it.
- Send a test email:** A button at the bottom left.

- Fill in the 'Subject' field with a desired subject – PBS Biotech suggests using the PBS-15/80's name.
- Fill in the 'Return Address' field with the email address the PBS-15/80 will email users from.
- Fill in the 'Password' field with the password to that email account.
- Fill in the 'SMTP Server' field with the SMTP Server address for that email provider.
- Fill in the 'SMTP Port' field with the SMTP Port available on your network; 587 is the most common, but consult the network administrator if it does not work.
- Click "Enable SSL?" if you wish to enable an encrypted link between the server and the mail client.

- (g) Enter email addresses in the 'Email List' to send alarm emails to.

NOTICE You can get alarm notifications as text messages. PBS Biotech Technical Support suggests researching SMS gateways to learn which email address to use for your phone number, or contacting your IT department for assistance.

- (h) Click "Send a test email" – a confirmation email should appear in the inboxes of the email accounts in the "Email List." If there is no confirmation email, check the entries in all the fields, and confirm internet connectivity.

7. If you wish to reverse changes you have made, click "Reset" and the file will revert back to its original values.
8. Once you have made the desired changes, click "Save." You can then choose to keep the current file name to save the changes made to that file, or you can rename it, thereby creating a new alarm file.

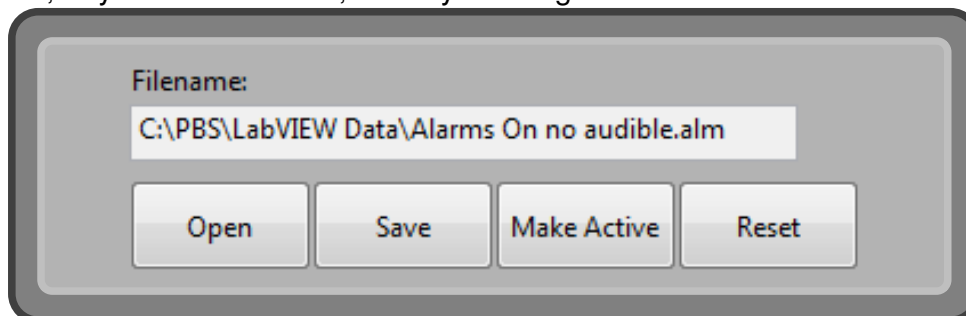

9. Click "Make Active" to make the selected file active on the RIO.

Configuring Automatic Backups

The PBS-15/80 can automatically back up the contents of the Database folder, including the active and archived databases and the Database History File.

NOTICE Users are responsible for their own backup and recovery.

Setting Automatic Backup Period

1. Log in to the Desktop UI with a user account with the "DB Management" permission.

2. Navigate to the File Browser menu.

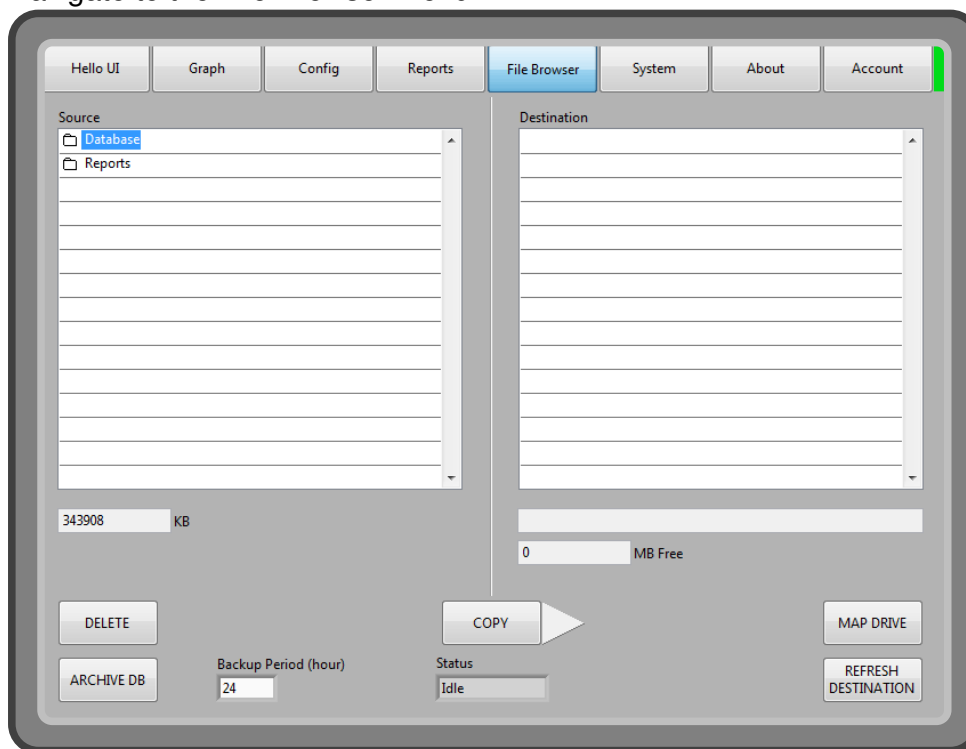

3. Set the Backup Period (hour) to the desired number of hours. PBS Biotech Technical Support recommends backing up at least every 24 hours.

Note: To disable automatic backups, set the Backup Period (hour) to 0.

Note: If the Backup Period (hour) is set to 24, the backups will occur at midnight. Otherwise, the backup schedule will be set such that the first backup will occur at the top of the hour after changing the period or rebooting the HMI.

Setting Automatic Backup Location

1. Log in to the Desktop UI with a user account with the “DB Management” permission.
2. Navigate to the File Browser menu

- Click the “Map Drive” button.

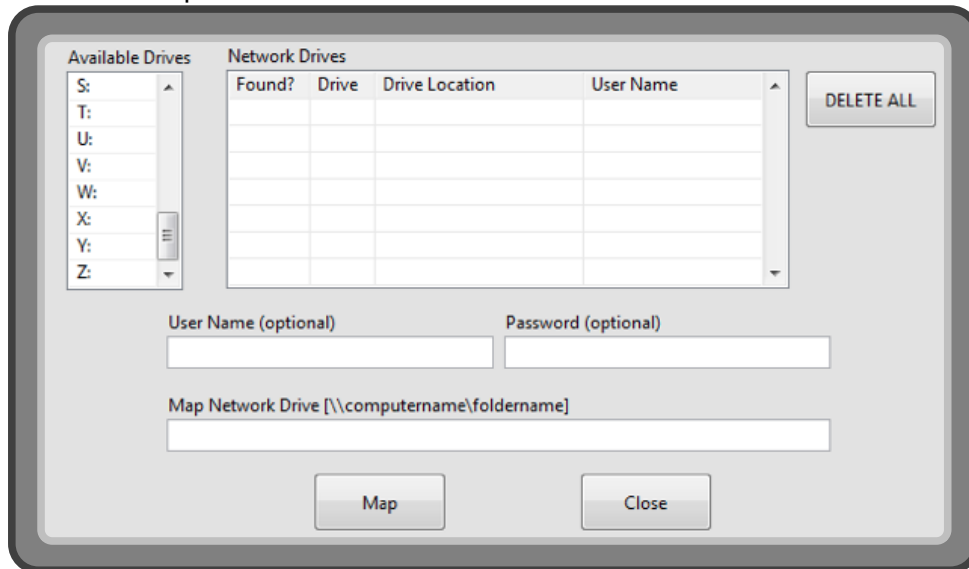

- Select the Z drive and enter the appropriate information in the User Name, Password, and Map Network Drive fields, then click “Map” and “Close.”
- The mapped network drive should appear in the list of Destinations. If not, check your network connection and consult your IT department.

Note: The PBS Software automatically backs up to the Z drive. Following the instructions above allows a user to map a networked drive to the Z drive. If users prefer using a physical external drive as the automatic backup location, have your IT department use their Administrator account on the HMI computer to configure a specific physical drive to be recognized as the Z drive.

Note: Although it is only possible to automatically back up databases to the Z drive, other networked drives may be mapped to other drive letters and used for manual backups of databases and/or reports.

Congratulations! You have now set up your PBS-15/80 and configured user accounts, logger settings, and alarms. Please see Chapter 6 for more details to begin using the PBS-15/80.

Before You Begin

This chapter will explain how to perform all the steps associated with a typical run, as well as tasks that a user may want to perform at any time from start to finish. Reading the preceding chapters is highly recommended before continuing.

Suggested Order of Operations

Set Up Run

1. HMI Computer Restart
2. 'Two-point' pH calibration
3. 'Two-point' DO calibration
4. Autoclave reusable sensors
5. Confirm gas source pressure matches specifications (see "Utility Requirements" on page 55)
6. Load Bag
7. Install bag in PBS-15/80
8. Check oxygen flow valve position
9. Check harvest valve alignment
10. Pressure 'Zero' calibration
11. Level 'Zero' calibration
12. First integrity test
13. Install reusable sensors in bag
14. Second integrity test
15. Add medium
16. Prime the harvest line
17. Level 'Span' calibration (if necessary)
18. Control temperature, agitation, and main gas as for process. Control DO and pH in Manual mode.
19. Wait for equilibration
20. 'One-point'/'Span' DO calibration
21. 'One-point' pH calibration

22. Control DO and pH in Auto mode
23. Load the Alarms On.alm file
24. Add cells
25. Start batch

During Run

1. Take Sample
2. Perform Medium feed/exchange (if applicable)

End Run

1. Load the Alarms Off.alm file
2. Harvest
3. End batch
4. Clean/decontaminate the PBS-15/80

Before Starting a Batch Run

Log In to the Hello UI

1. If the screen is currently displaying the Desktop UI, click the “Hello UI” button to launch the Hello User Interface, and wait for the page to load.
2. Click anywhere to go to the Login menu.

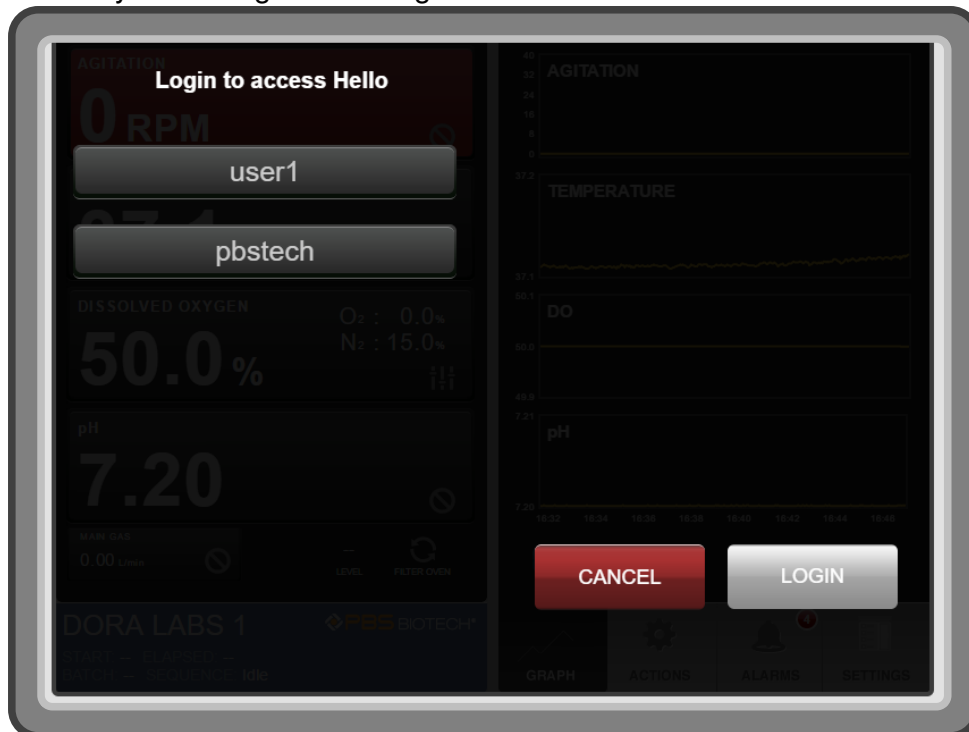

3. Select your user name from the menu.
4. Enter your password with the on-screen keypad, or with an external keyboard.
5. Click “Login.”

Restarting the HMI Computer

Like any computer, the bioreactor’s HMI benefits from occasional reboots. Doing so before starting a run is especially beneficial if the bioreactor has been on for a significant amount of time.

To Restart the HMI with the Hello UI:

1. Navigate to the “Actions” tab.
2. Click the “Shutdown” button.

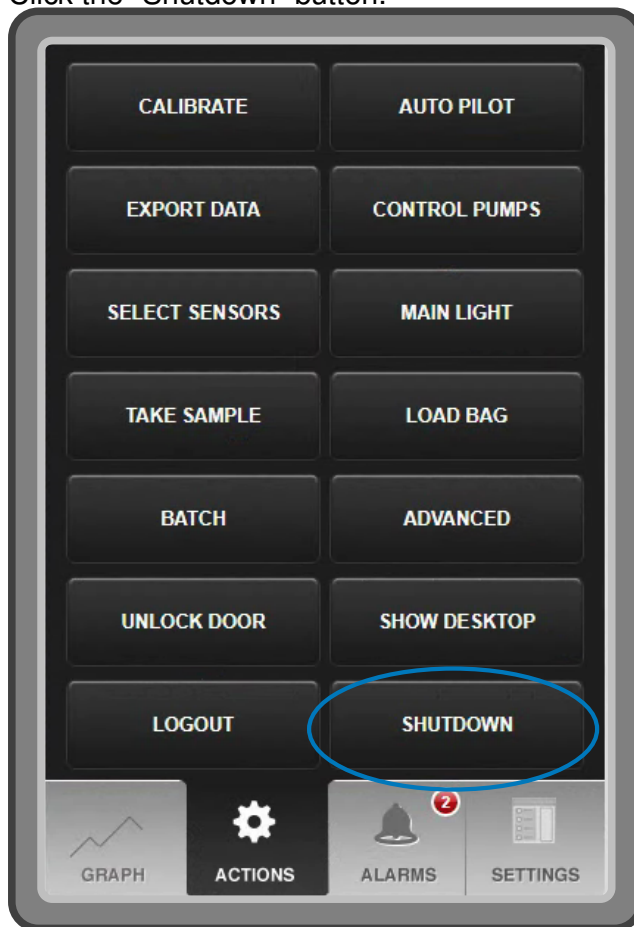

3. Select the “Restart” option.

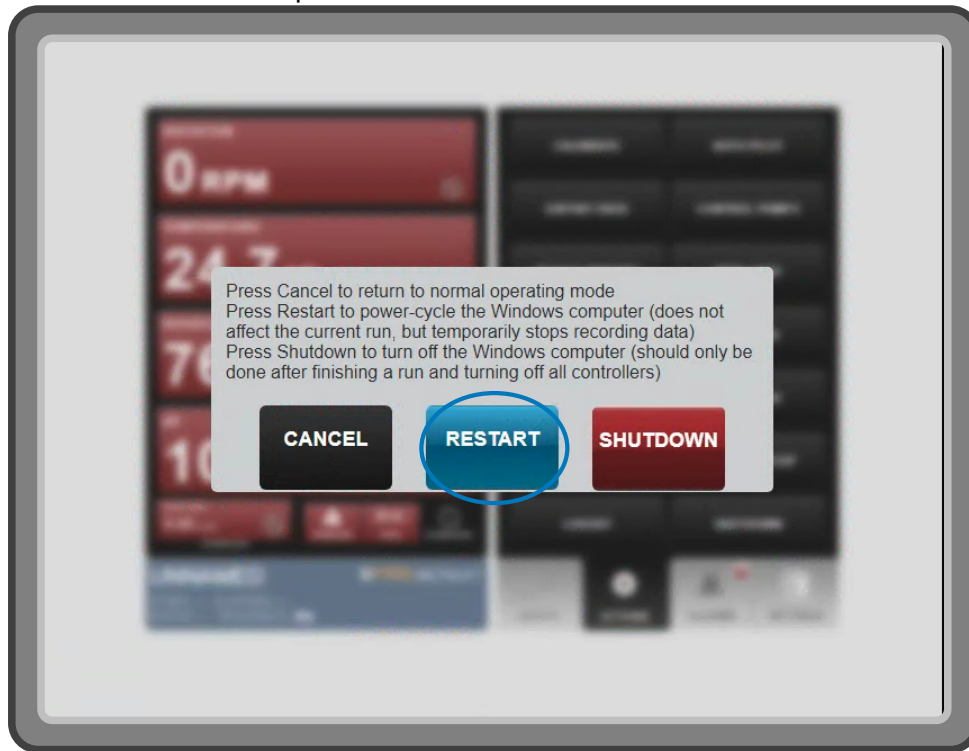

Calibrating Reusable pH Sensor

Before calibrating:

- Confirm the pH sensor is compatible with the PBS-15/80. The standard PBS-15/80 configuration is compatible with most combination electrodes with an S8 connector. If your PBS-15/80 has been custom built for different pH sensors, please consult PBS Biotech Technical Support to determine compatible sensors.
- Inspect the pH sensor. Confirm the sensor tip is filled with electrolyte solution and there are no bubbles.
- Connect the pH cable to the pH sensor by mating the two together and threading the articulating collar completely to secure.

NOTICE Do not twist the pH cable as this may damage it.

Two-point pH calibration with the Hello UI

1. Navigate to the “Actions” tab.
2. Click “Calibrate.”



3. Enter buffer temperature in the ‘Calibration Solution Temp’ field.
4. Enter buffer 1 value in the ‘Zero’ field.
5. Place pH sensor (and grounding wire, if applicable) in buffer 1.
6. Wait for the graph to stabilize.
7. Click the “Calibrate 1” button.
8. Enter buffer 2 value in the ‘Span’ field.
9. Place pH sensor (and grounding wire, if applicable) in buffer 2.
10. Wait for the graph to stabilize.
11. Click the “Calibrate 2” button.
12. Click “Save.”
13. Place pH sensor (and grounding wire, if applicable) in buffer 1.
14. Confirm the displayed pH PV is close to the actual value of buffer 1.
15. Click “Close.”

For more information, see “‘One-point’ pH calibration” on page 112.

Calibrating Reusable Dissolved Oxygen Sensor

Before calibrating:

- Confirm the DO sensor is compatible with the PBS-15/80. The standard PBS-15/80 configuration is compatible with most polarographic DO electrodes with a D4 connector. If your PBS-15/80 has been custom built for different DO sensors, please consult PBS Biotech Technical Support to determine compatible sensors.
- Confirm that within the last 6 months, the electrolyte solution in the tip has been changed, and the anode has been confirmed to be free of corrosion.
- Connect the DO cable to the DO sensor by aligning the keys on the cable adapter and pushing the two components together. Then twist the articulating collar to secure.
- For polarographic sensors, ensure the sensor has been connected at least 6 hours before performing calibration.

Two-point DO calibration with the Hello UI

1. Confirm the sensor is fully polarized.
2. Navigate to the “Actions” tab.
3. Click “Calibrate.”
4. Click “DO A.”

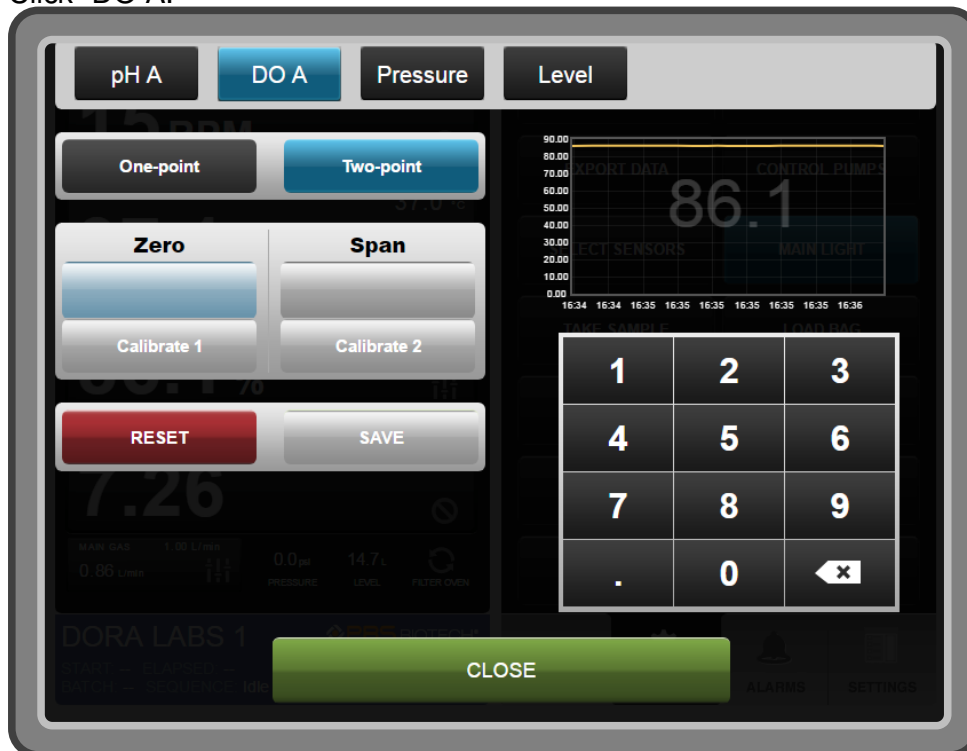

5. Enter '100' in the 'Zero' field.
6. Click the "Calibrate 1" button.
7. Disconnect the polarized DO sensor.
8. Enter '0' in the 'Span' field.
9. Wait for the graph to stabilize.
10. Click the "Calibrate 2" button.
11. Click "Save."
12. Click "Close."
13. Reconnect the sensor.
14. Wait for the graph to stabilize. It should read 100%.

Note: The operator could change the order, and calibrate to 0% for the 'Zero' field and 100% for the 'Span' field. However, the method suggested above has the advantage of calibrating to 100% when the sensor has been polarized for hours.

Note: When the DO sensor is disconnected, present value should be 0%.

For more information, see "One-point/'Span' DO calibration" on page 110.

Autoclaving Reusable Sensors

Prepare individual sensors to be autoclaved:

1. Check that the Kleenpak™ pouch's zip tie is tight enough. Hold the pouch with one hand and the plunge protector with the other hand, and gently pull them in opposite directions to check whether the zip tie (covered with tape) moves or is loose. If the tube does not stay firmly in place, discard that Kleenpak™ pouch and use a backup.

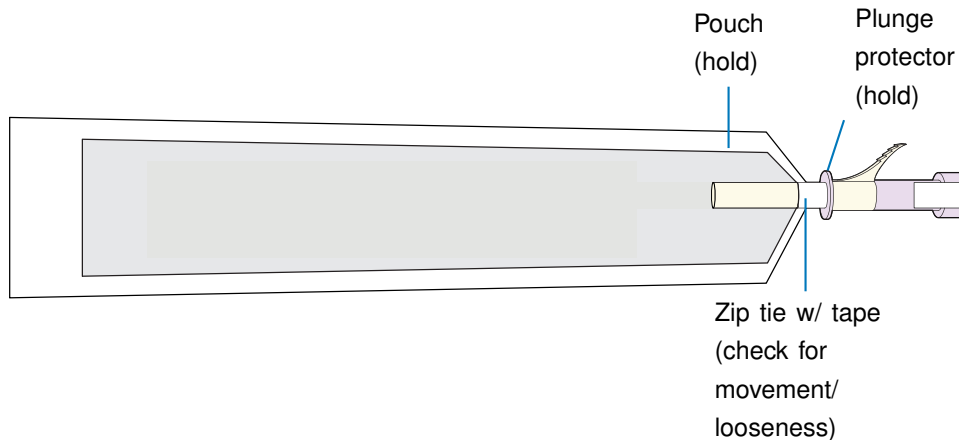

2. Cover the part of the sensor that connects to the cables on the PBS-15/80, using the screw cap that came with the sensor.
3. Clean the sensor, being sure to rinse with DI water.
4. Screw the sensor into the converter that came with the Kleenpak™ pouch.
5. Gently tighten the sensor to compress the O-ring using a crescent wrench.
6. Place the sensor in the autoclave pouch, with the sensor tip in the silicone tubing.

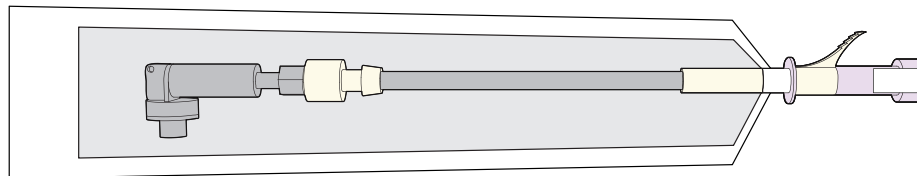

7. Seal the pouch.
8. Place the sensor in the autoclave. Arrange sensors so they are angled with the sensor tip lower than the part of the sensor that connects to the cable.

- Autoclave per Standard Operating Procedure of your bioprocessing facility, using either slow exhaust or liquid cycle. The temperature should be 121 °C for at least 30 minutes.

Load Bag

To load a bag:

- Navigate to the “Actions” tab.
- Click “Load Bag.”



- Enter the bag gamma date.
- Enter the bag part number.
- Enter the bag serial number.
- Do not enter calibration values for any reusable or single-use sensors that will be utilized.
- Click “Load Bag.”

Install Bag in PBS-15/80

Note: These instructions are for the standard PBS-15/80 Bioreactor bag configuration. If your bag is different, please consult its installation protocol.

- Remove the PBS-15/80 Bioreactor bag from the outer packaging.

2. If applicable, make connections to tubing in a biosafety cabinet. This could include connecting the sample line to a transfer flask (see “Take Sample” on page 116).
3. Use a screwdriver to mechanically override the door lock (A. pictured below), and open the door (B. pictured below).

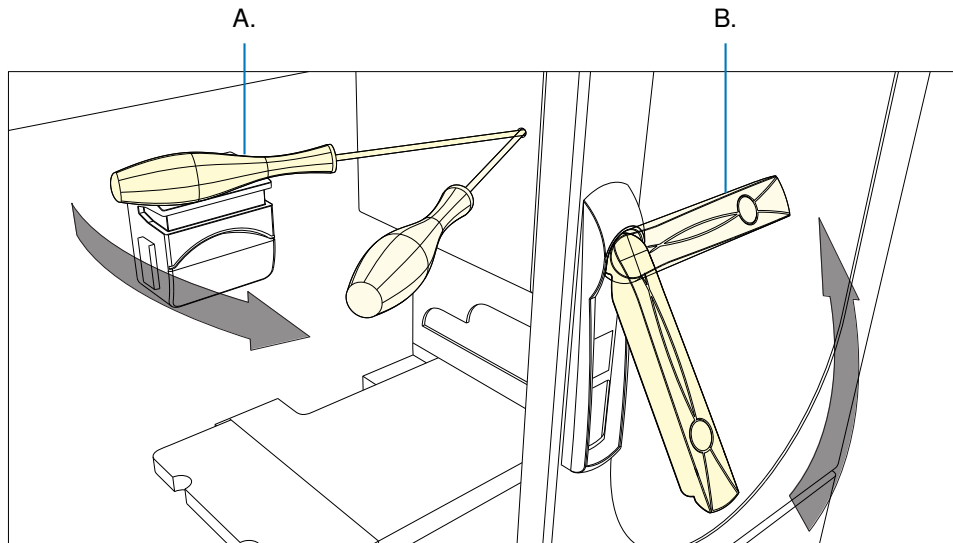

4. Check that nothing is in the chamber.
5. Holding the bag upright by the side tabs, slide the bag into the chamber, aligning the ports at the side and bottom of the bag with the slotted openings of the chamber. Make sure the top of the harvest valve is properly inserted into the matching support at the bottom of the bag. Fold the side tabs down to the side of the bag.
6. Slide each tube at the top of the bag into its designated slot on top of the chamber.
7. If applicable, install the bag hanger on its support screws.

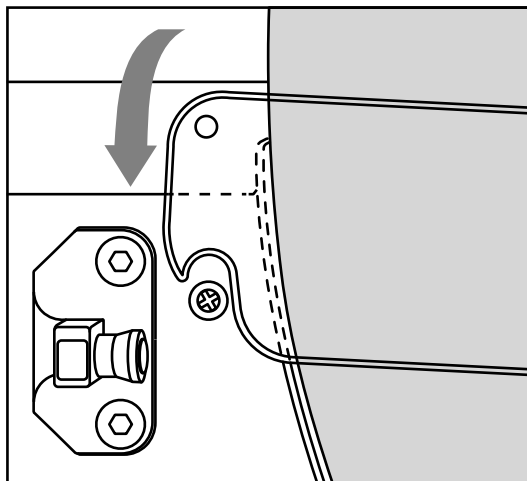

8. Close the door, making sure the tubing is not in the way.

9. Remove the tubing sets from their bags. The tubing is color-coded to match the corresponding connectors and pumps on the PBS-15/80.

Connector/Pump	Tube Color
Main-gas connector	Black
Micro-gas connector	Green
Sample	Red
Addition A	Brown
Addition B	Gray
Media	Orange

10. Leave the tubing lines on top of the PBS-15/80 so they do not get in the way during installation.
11. Install the exhaust filter tubing:
- (a) Install the condenser bag in the receptacle and the exhaust filter in the filter oven.

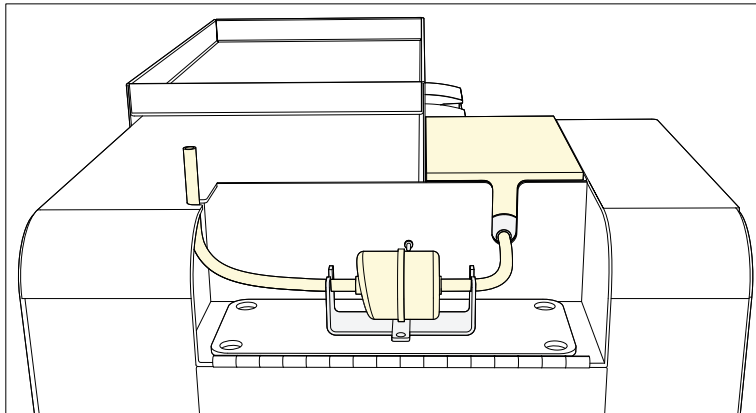

- (b) Close the filter oven door.
- (c) Attach the pressure sensing line to the pressure sensing connector, routing it in front of the other tubing lines coming out of the top of the bag.

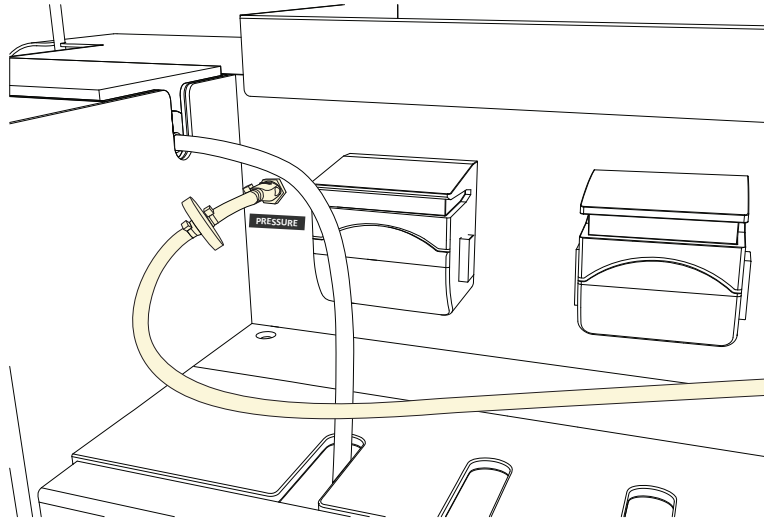

- 12. Connect the Main-gas line to the Main-gas connector.
- 13. Connect the Micro-gas line to the Micro-gas connector.

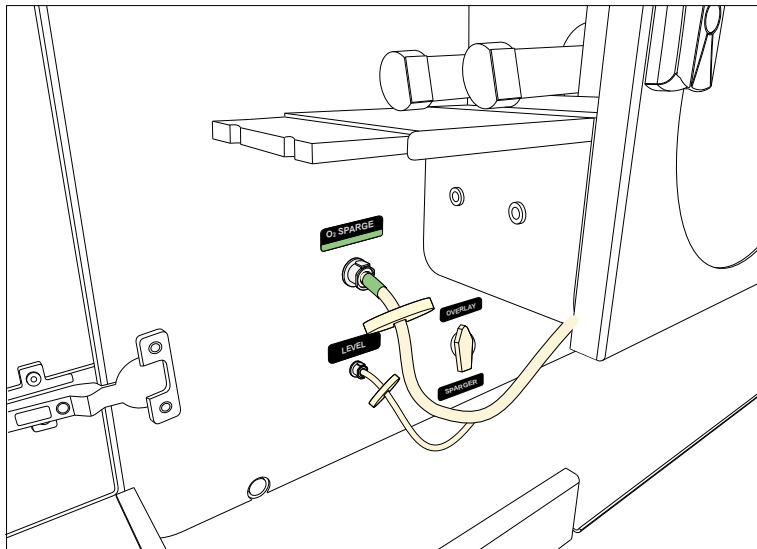

- 14. Connect the level sensing line to the level sensing connector. Be sure to read the “Level sensing line” warning on page 21.

15. Connect the harvest valve base to the stabilizing block using the turn screw. Tighten the stabilizing block to the positioning shaft with the wing nut so the harvest valve is fully disengaged (see “Figure A: Disengaged harvest valve” on page 89).

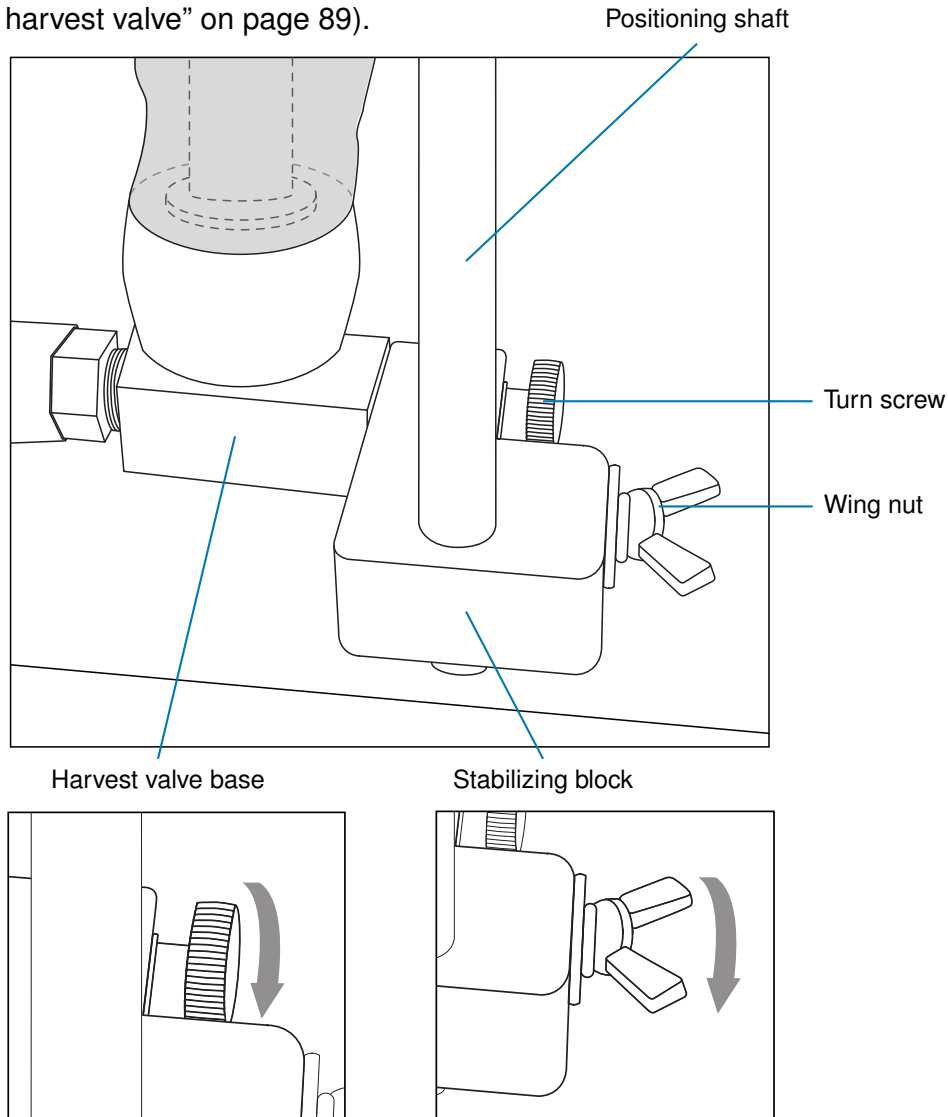

Check Oxygen Flow Valve Configuration

At the beginning of a run, even for a process with a high O₂ consumption rate, O₂ should be configured to flow through the overlay, instead of sparging.

1. Set the oxygen flow valve to “Overlay.”
2. Set the DO “O₂ P Gain (%/DO%),” “O₂ I Time (min),” and “O₂ D Time (min)” settings to the correct value for the configuration (see Appendix 1 “DO” section on page 199).

For more information, see “Oxygen Flow Valve” on page 179.

Check Harvest Valve Alignment with Harvest Mode

Confirm the harvest valve alignment feature works:

1. In the Desktop UI, click “Graph” and then “Agitation.”
2. Click the “Harvest” button and wait until the Harvest Status says “In Harvest Mode.”
3. Confirm that when the Vertical-Wheel[®] impeller stops, one of its open channels is directly aligned with the harvest port in the bag (see Figure A below). If the opening is to the left of the harvest port, decrease the Delay (s) value. If it is to the right of the harvest port, increase the Delay (s) value. Then repeat step 2.

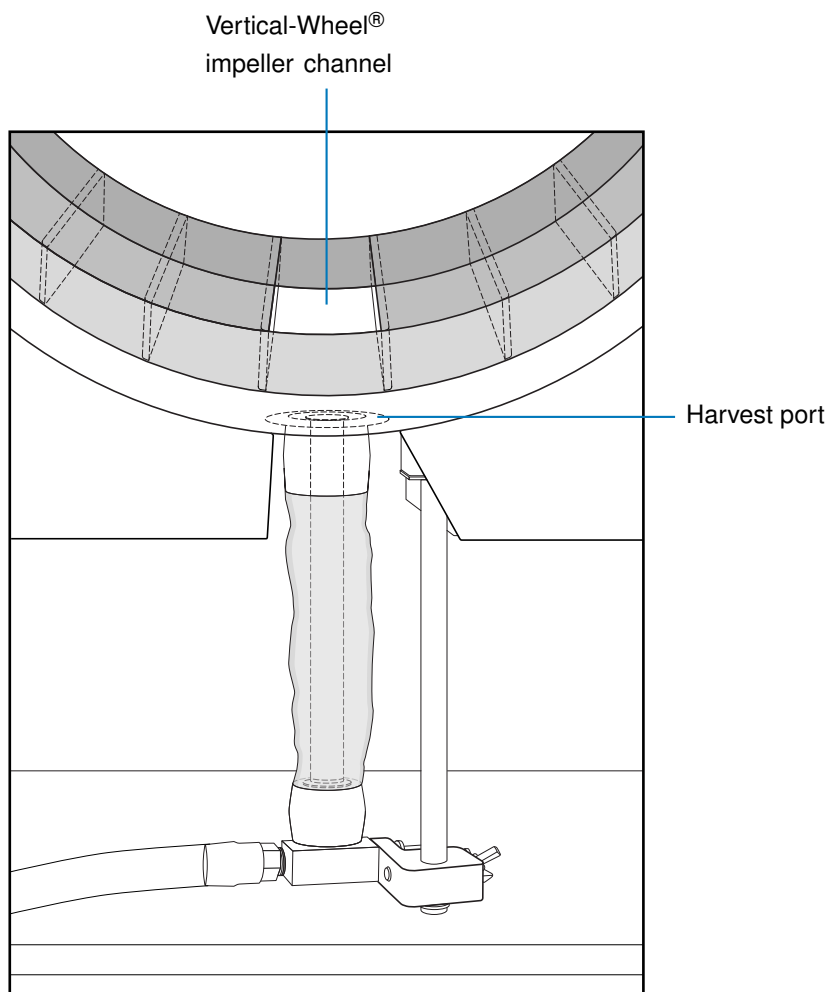

Figure A: Disengaged harvest valve

4. Make sure the harvest mode positioning allows the harvest valve to be fully engaged (see Figure B below):
 - (a) Loosen the stabilizing block from the positioning shaft by turning the wing nut.
 - (b) Slide the harvest valve up and through the Vertical-Wheel® impeller to confirm its path is not obstructed.

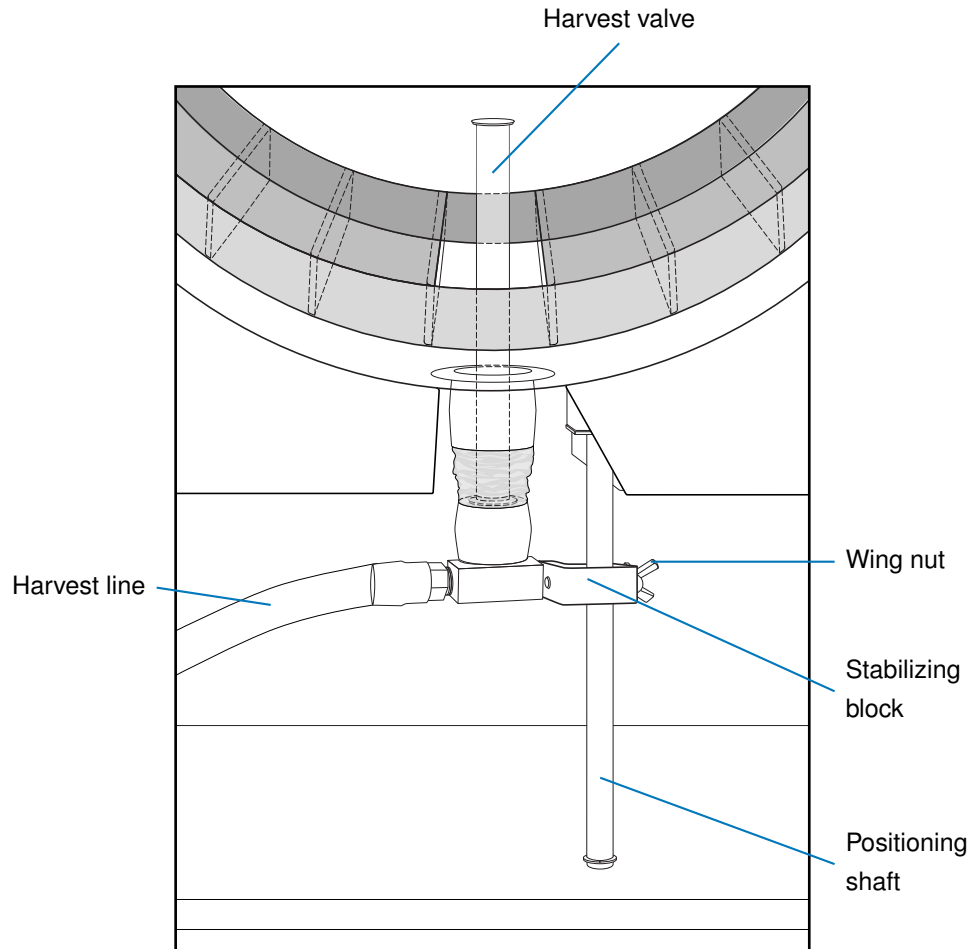

Figure B: Engaged harvest valve

5. Return the harvest valve to its fully disengaged starting position and tighten the stabilizing block to the positioning shaft with the wing nut.
6. Click the “End Harvest” button in the “Agitation” graph in the Desktop UI and confirm.

Pressure ‘Zero’ Calibration

Pressure ‘Zero’ calibration with the Hello UI:

1. Confirm the pressure sensing line is connected to the PBS-15/80 and is not clamped or kinked.

2. Confirm the bag is completely depressurized and no gases are flowing.
3. Navigate to the “Actions” tab.
4. Click “Calibrate.”
5. Click “Pressure.”

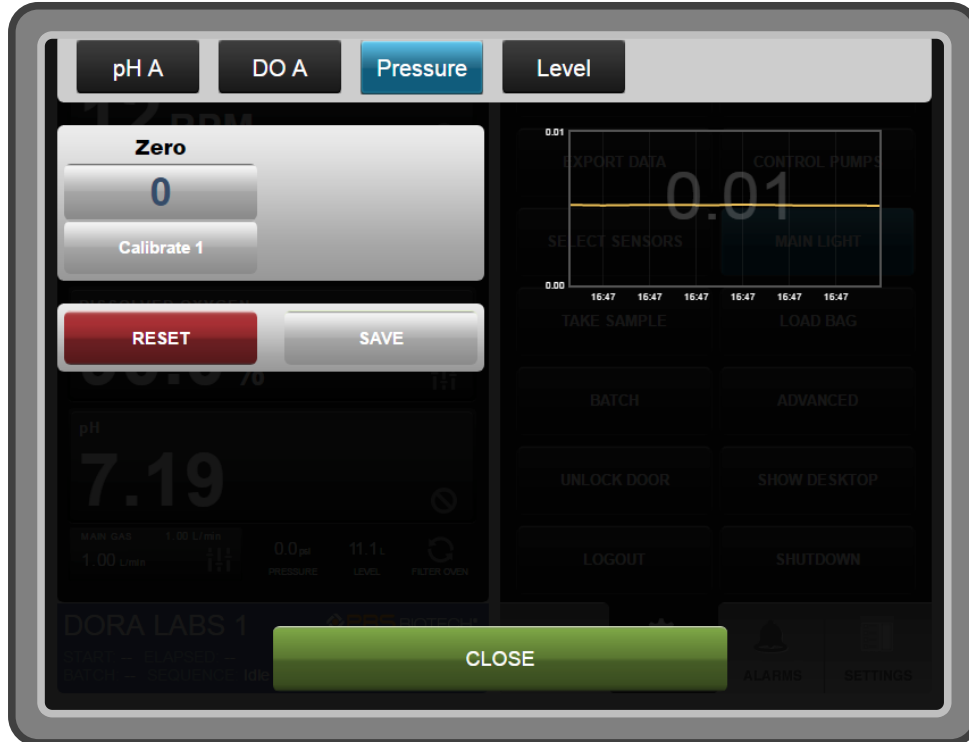

6. Click the “Calibrate” button.
7. Click “Save.”
8. Click “Close.”

Level ‘Zero’ Calibration

Level ‘Zero’ calibration with the Hello UI

1. Confirm the level sensing line and pressure sensing line are connected to the PBS-15/80 and are not clamped or kinked.
2. Confirm the bag is empty and completely depressurized, no gases are flowing, agitation is off, and the pressure PV is 0 (re-calibrate the pressure sensor, if necessary).
3. Navigate to the “Actions” tab.
4. Click “Calibrate.”
5. Click “Level.”

- Click “Zero.”



- Click the “Calibrate” button.
- Click “Save.”
- Click “Close.”

Note: Outside of the calibration menu, the Hello UI will report the level PV as “--” when the software recognizes the level PV as exactly 0.0 L. This behavior should be expected after performing a ‘Zero’ calibration or below empty level setting.

Integrity Test

Confirm that the bag was not damaged in shipping by performing the following integrity test. If using reusable sensors, perform the integrity test once before installing the sensors, and once after installing them.

Note: The acceptance criteria specified in step 7 should be treated as a guideline. Users can create their own protocol and acceptance criteria to confirm their bags were not damaged in shipping.

- Allow the bag to completely depressurize and confirm that when the pressure sensing line is connected, the pressure PV reads 0.0 psi.

2. Set up for the test:

- (a) Confirm that the Safety “Max Pressure (psi)” setting is 0.5.
- (b) Disconnect the Micro-gas line.
- (c) Clamp all lines except the Main-gas line and pressure sensing lines. The exhaust line does not have a built-in clamp so an external clamp must be used to clamp it.

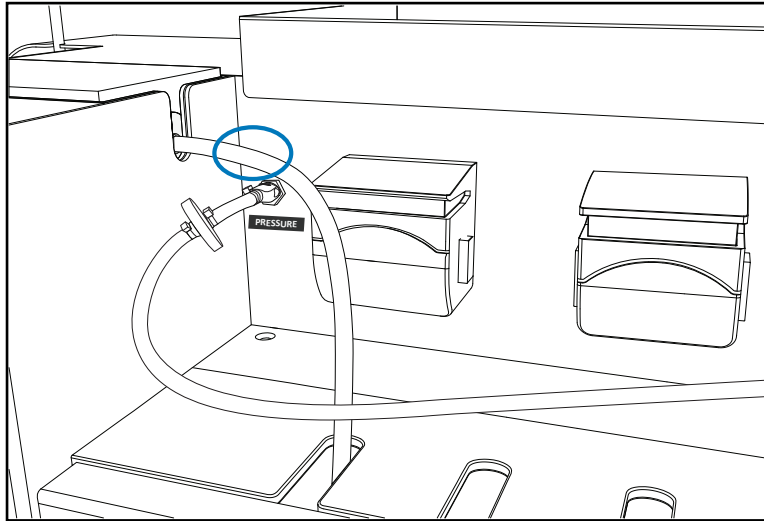

- (d) The level sensing line should also be clamped and disconnected. Clamp sensor ports which do not have sensors installed. Do not clamp the tubing on any sensor port with an installed sensor.

3. Navigate to the “Actions” tab and click “Load Bag,” then “Integrity Test.”



4. Click the green “Start Test” button, and then click “Start” to confirm.
5. Observe the graph as the test progresses. During the test, do not turn agitation, DO, or Main Gas on, as it will cancel the test. Also, during the test, do not log out or refresh the Hello UI page, or navigate away from the “Integrity Test” menu, as the “Starting Pressure,” “Final Pressure,” and “Decay” values will not be retrievable.
6. When the test progresses from “Charge” to “Settle,” disconnect the Main-gas line.

7. After the test has finished, confirm the following values:

Starting Pressure:	0.4 psi or higher
Decay Rate (PBS-15):	0.0045 psi/min or lower
Decay Rate (PBS-80):	0.0020 psi/min or lower

The “Starting Pressure,” “Final Pressure,” and “Decay” values will be displayed in the Integrity Test menu, and will also be recorded in a user event when the test finishes.

8. If the starting pressure or decay rate was not acceptable according to the above criteria, run the test again. First, remove the clamp from the exhaust line to release the pressure in the bag. When the pressure has returned to 0.0 psi, re-clamp the exhaust line and confirm that all clamps are properly tightened. If performing the test after installing reusable sensors, confirm that the clamps around the sensors are fully actuated and that the Kleenpak™ connectors are fully locked.
9. If the test results were still not acceptable, try restarting the RIO and HMI computers (see “Reboot RIO” on page 138 and see “Restarting the HMI Computer” on page 78).
10. Remove the clamp from the exhaust line to release the pressure in the bag. When the pressure has returned to 0.0 psi, you can remove the other clamps and reconnect the level sensing line.
11. Reconnect the Main-gas line and Micro-gas line.

Install Sensors

After the installed bag passes the first integrity test, remove the clamps on the sensor ports and install the autoclaved reusable sensors.

CAUTION! Wait until the reusable sensors are cool to the touch before installing them in the bag.

To install a reusable DO sensor:

1. Remove the protective cap (NOT the paper) from the Kleenpak™ connectors on the PBS-15/80 Bioreactor bag's sensor port furthest from you, and on the autoclave pouch.

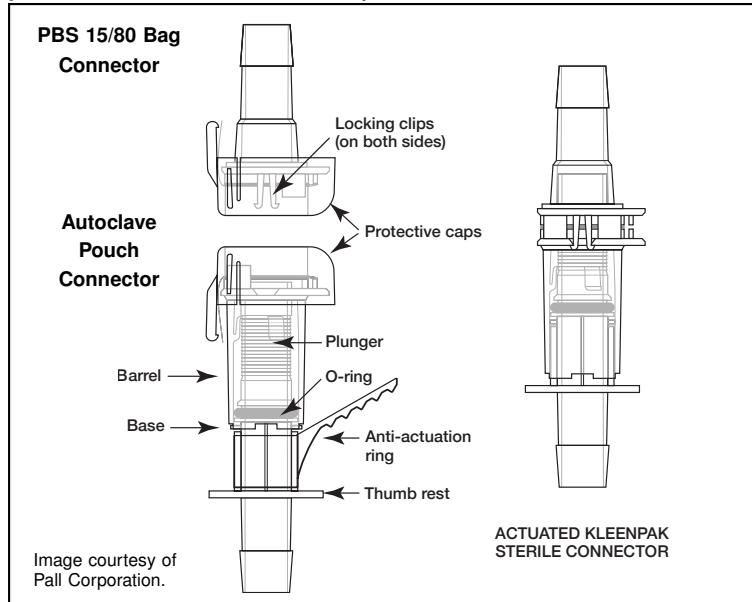

2. Holding both connectors, orient them so the flat sides are aligned and the peel away strips are folded and exit the same side.

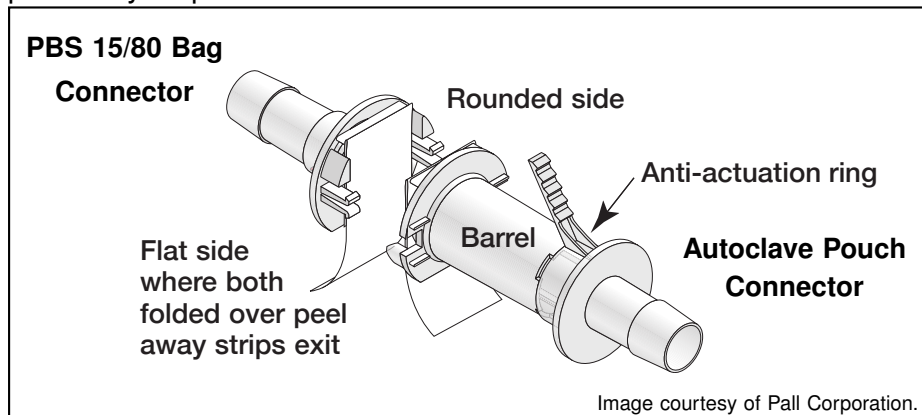

3. Press the two Kleenpak™ connectors firmly together until both locking clips snap together.

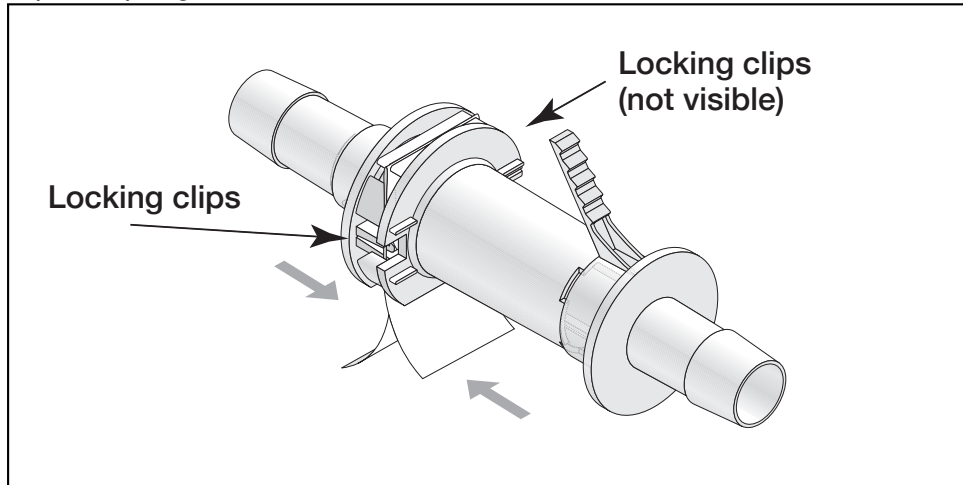

4. Continuing to hold both connectors as positioned in step 3, remove the beige anti-actuation ring from the autoclave pouch by pulling the tab away from the PBS-15/80 Bioreactor bag.

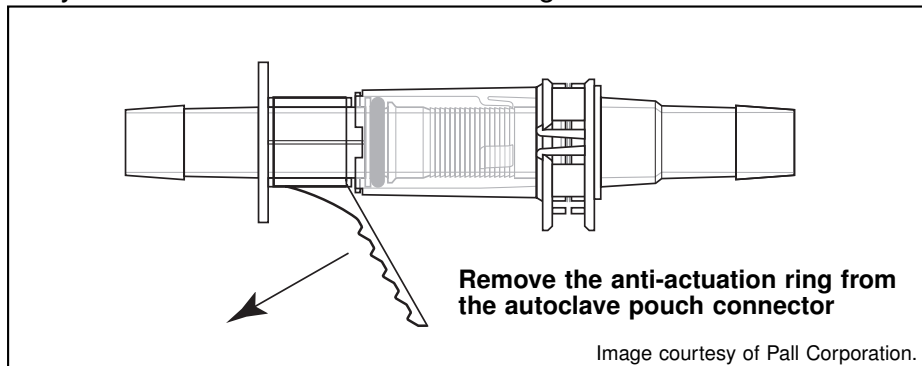

5. Make the sterile connection:

- Continuing to hold both connectors in one hand, remove both peel away strips at the same time (A. and B. pictured below).

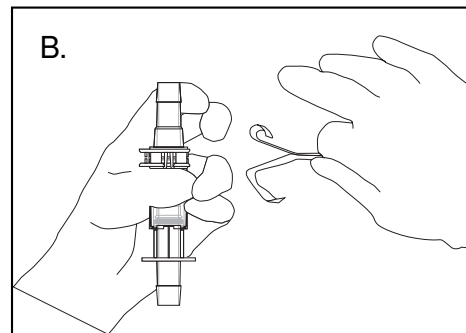
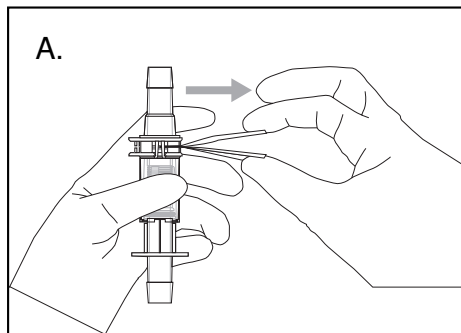

- Immediately push the thumb rest of the autoclave pouch's connector down towards the base of the barrel until they meet. Verify that the plunger is fully inserted in the connector by pushing until a hard stop is reached (C. and D. pictured below).

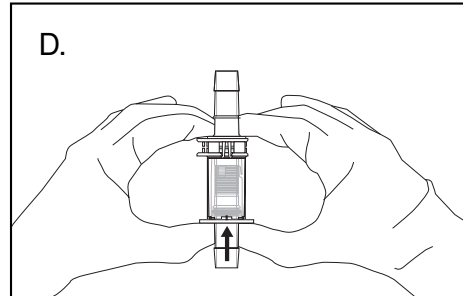
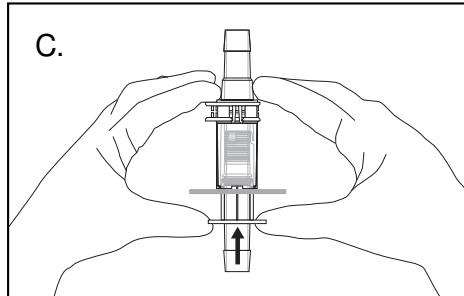

6. Push the sensor in the pouch through the new connection until the barbed end of the converter is fully in the silicone tubing.

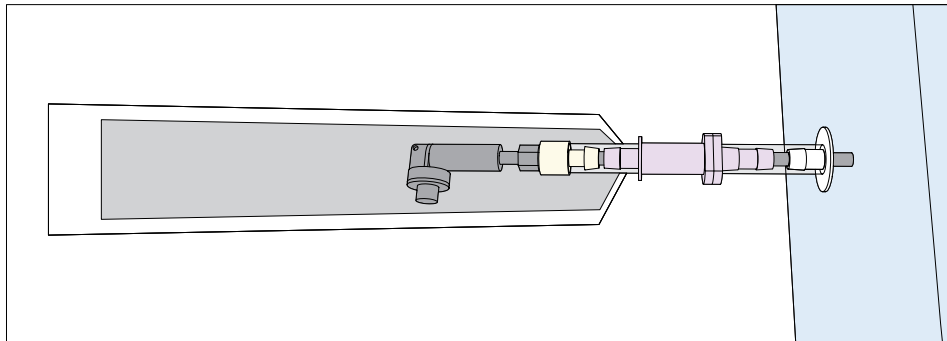

7. Tighten the black clamp midway between the two zip ties, using adjustable pliers if necessary. For optimal tightness, all teeth on the clamp should be engaged.

8. Cut away the autoclave pouch with a pair of scissors, being careful around the PBS-15/80 Bioreactor bag. Apply the second black clamp so it tightens the silicone tubing from the autoclave pouch around the sensor.
- Tighten the clamp around the sensor (A. pictured below) – all teeth should be engaged.
 - Remove pouch (B. pictured below).
 - Apply and tighten the clamp around the barbed end of the converter (C. pictured below). Not all teeth will be engaged.

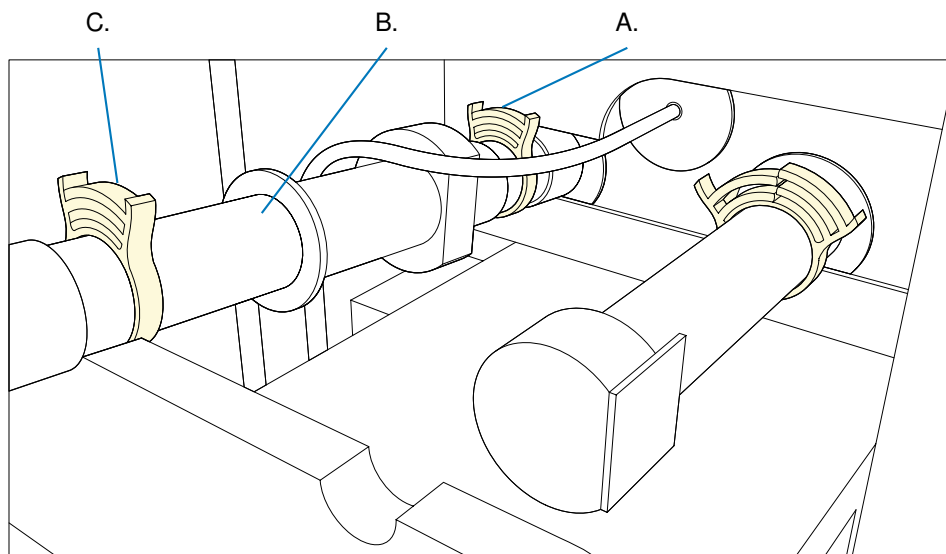

To install a reusable pH sensor:

Repeat the steps in the above “To install a reusable DO sensor” section (starting on page 95) using the other sensor port in the PBS-15/80 Bioreactor bag.

Finish sensor installation:

Connect the cables to the pH and DO sensors, as in “Calibrating Reusable pH Sensor” on page 79, and “Calibrating Reusable Dissolved Oxygen Sensor” on page 81. If the pH cable has a grounding wire, attach it to the DO sensor so it will be grounded in the medium. Flip up the holder on the sensor platform so the sensors can rest on it at the proper angle.

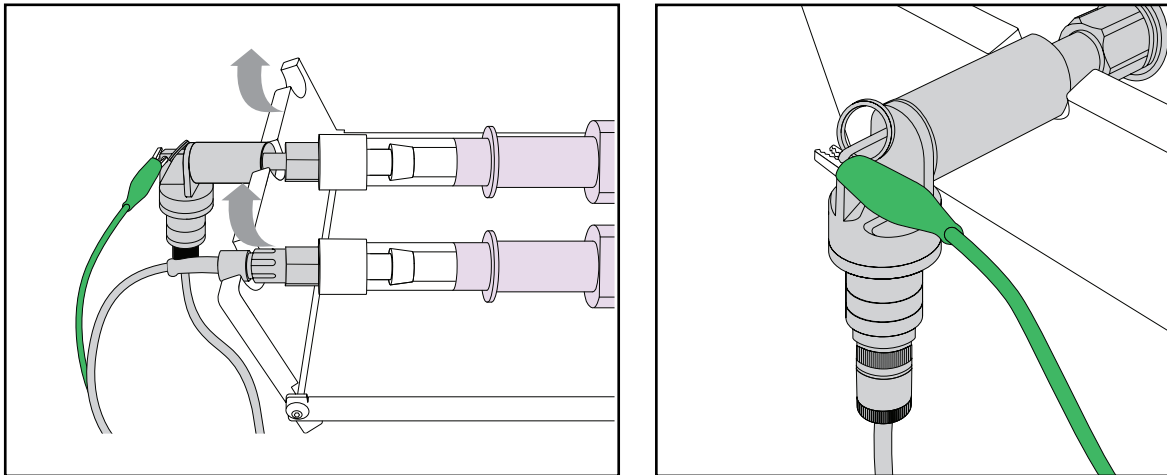
**Second Integrity Test**

Repeat the integrity test with the reusable sensors installed to confirm that the sensors were installed correctly. For more information, see “Integrity Test” on page 92.

Starting a Run**Using the Pumps**

This section includes instructions for actually using the pumps. For more information about how they work, see “Control Pumps” on page 157.

The tubing lines on the standard bag have a silicone section, close to the bag, and a C-Flex[®] section, at the end. The C-Flex[®] is weldable, but not pumpable, and attempting to pump it can compromise the sterility of the bag. Only pump the silicone tubing.



NOTICE Depending on the model of bag being used, some of the tubing lines may not be compatible with the pumps installed on the PBS-15/80 and will require the use of an external pump.

Tube holder positioning for smaller pumps

The pumps must be adjusted for the size of tubing being used. If the outer diameter of the tubing is 1/4 in. or smaller, the “inner” position should be used. For tubing with outer diameter of 5/16 in., the “outer” position should be used.

The pumphead can be adjusted to accommodate 1.6mm wall tubing in sizes from 0.5mm bore to 4.8mm bore.

Tube holder position

Tube bore size	0.5mm	0.8mm	1.6mm	2.4mm	3.2mm	4.0mm	4.8mm
Inner 	✓	✓	✓	✓	✓	✗	✗
Outer 	✗	✗	✗	✓	✓	✓	✓

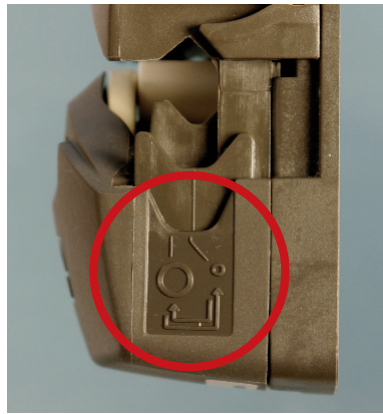

Inner position, for small tubing

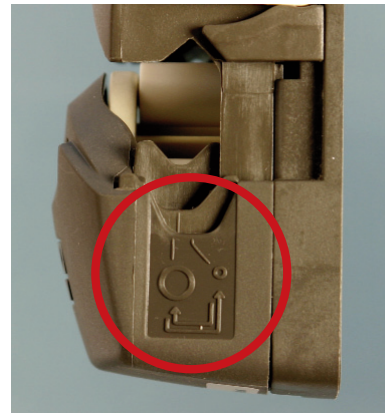

Outer position, for large tubing

With the smaller bore tubes of 0.5mm, 0.8mm and 1.6mm the inner position must be used to prevent the risk of tube slipping through the clamps and wandering across the rollers causing premature tube rupture.

With the larger bore tubes of 4.0mm and 4.8mm the outer position must be used to prevent the flow rate being excessively reduced.

For tubing bores of 2.4mm and 3.2mm either setting may be used, as appropriate for the application. The inner setting will clamp the tube harder, reducing tube slip but has the potential to marginally reduce flow rate. The outer setting will optimise flow rate but the risk of tube slip is increased.

○ → ● To change from the large tube to the small tube setting

Switch off the pump before changing the tube holder position. Use a pointed device such as a ball-point pen to reposition the lower tube holders **on both sides** of the pumphead.



- Lift the flip top until fully open.
- Place the pointed device pointing down into the small depression pictured here.

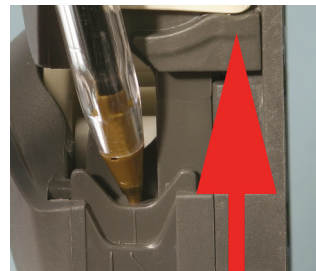
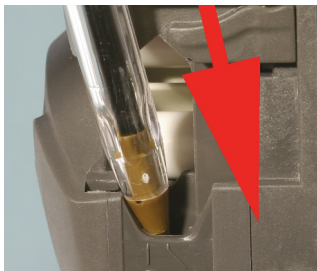

- Press down and slightly away from the front of the pumphead, as shown in the first picture above.
- Maintain the angled downward pressure and push away from the front of the pumphead. The jaw clicks into a new position.
- Release the pressure. The jaw rises into its correct alignment. If it does not rise, repeat the procedure, being sure to maintain downward pressure until release.
- Adjust the tube holder on the other side of the pumphead in the same way.

● → ○ To change from the small tube to the large tube setting

Carry out the procedure described above, but pushing towards the front of the pumphead.

Note: The pictures on the previous page show the tube holders' correct positions for small and large tubing. If a tube holder is not vertical relative to the body of the pumphead, it is wrongly positioned. Follow the instructions above to reposition it.

Tube holder positioning for larger pumps

For the larger pumps, the tube holder should be positioned to either the 1.6 or 2.4 setting, depending on the tube bore size.

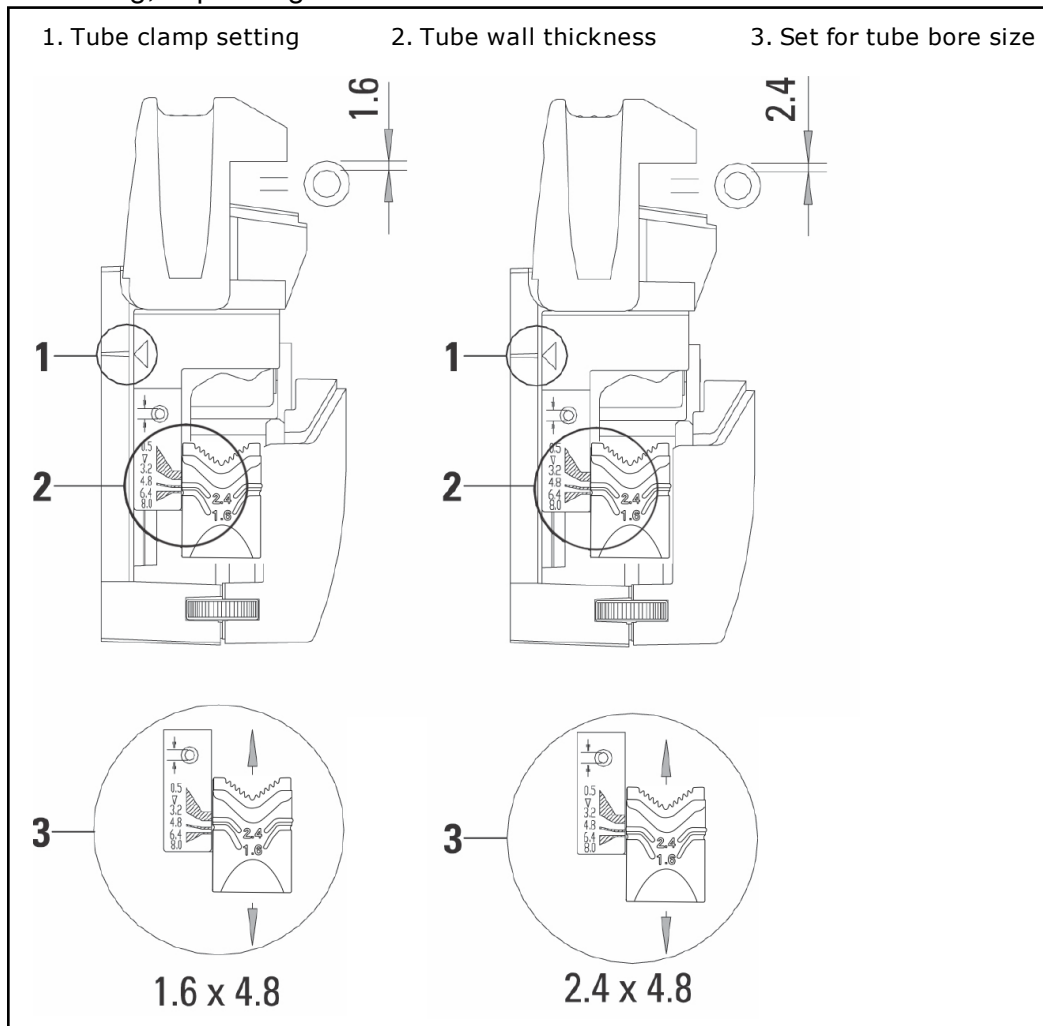

Tube loading for smaller pumps



Switch off the pump before tube loading.

Check that the tube holders on both sides of the pumphead are correctly set for the size of tube you are using.

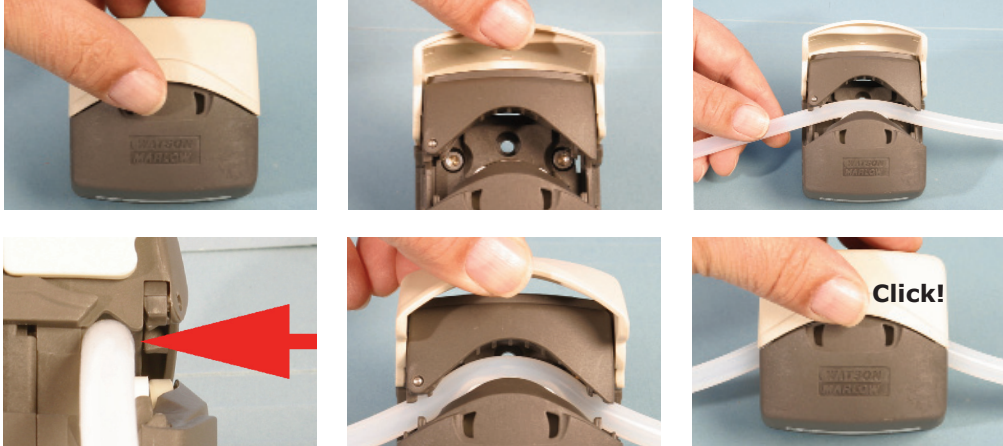

- Lift the flip top until fully open.
- Select enough tube length for the curve of the pump track. Place the tube between the rotor rollers and the track, pressed against the pumphead inner wall. The tube must not be twisted or stretched against the rollers.
- Lower the flip top until it clicks into its fully closed position. The track closes automatically and the tube is stretched correctly as it does so.

Tube loading for larger pumps

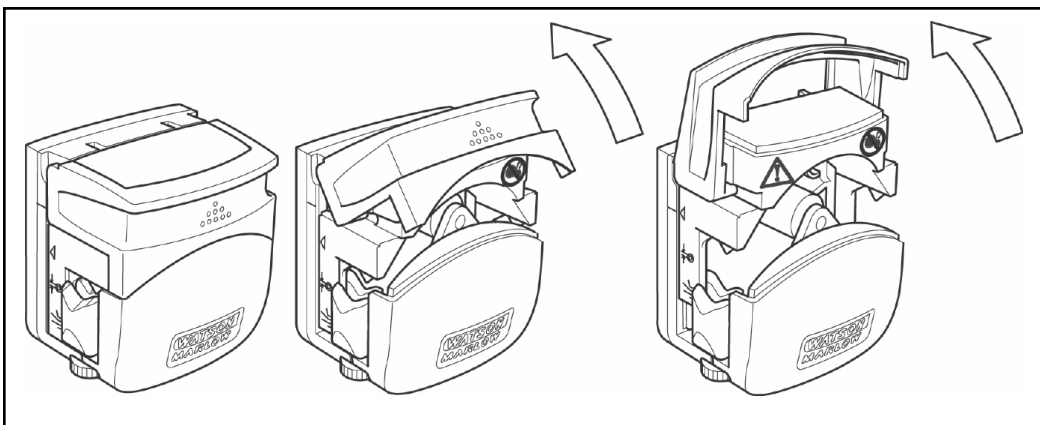

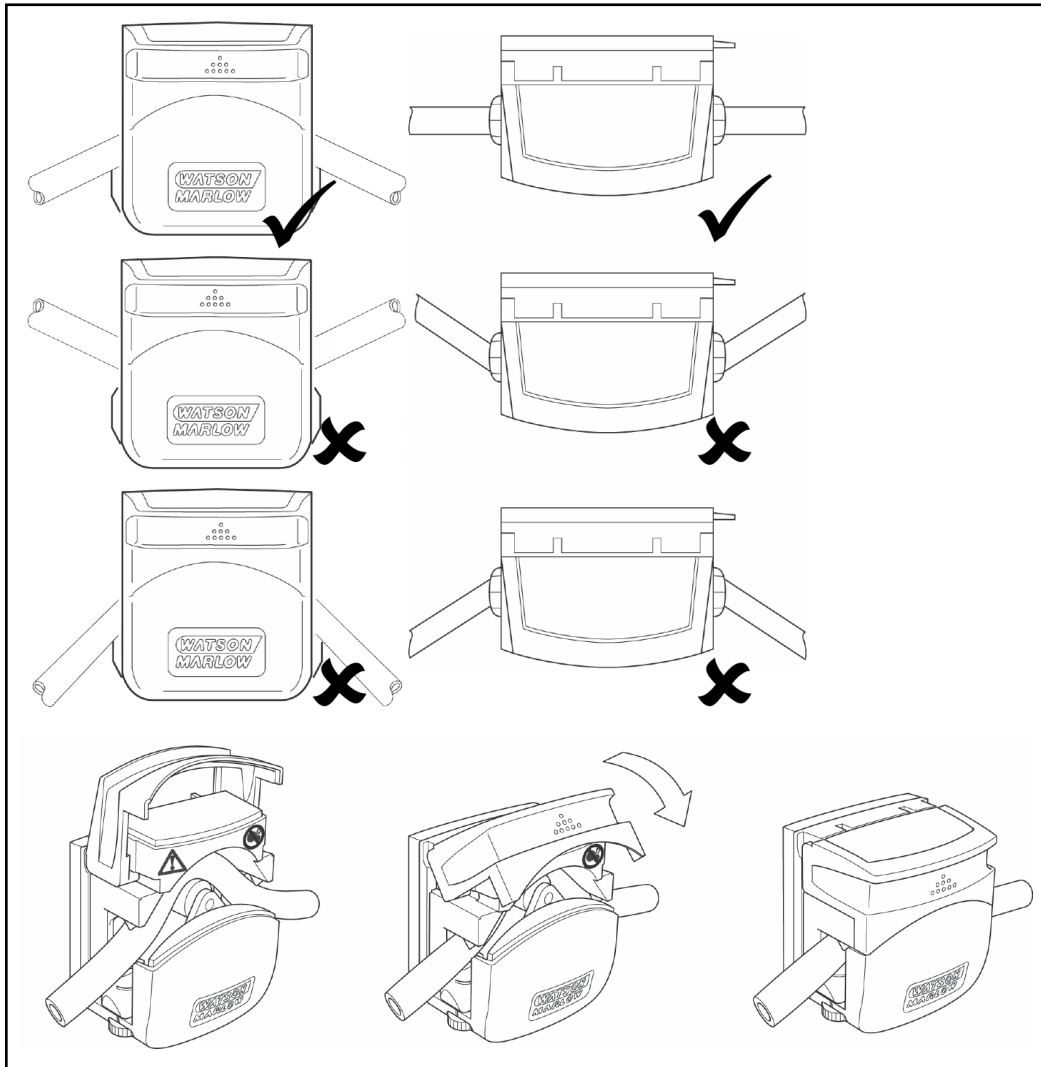

Using gravity

To avoid unnecessary wear on the silicone tubing, and exposing cells to unnecessary shear stress, use the pumps only to prime the tubing, and then use gravity for the rest of the liquid transfer when possible.

Accessing the Pumps menu

1. Log in to the Hello UI as a user with the “Controls” permission.
2. Navigate to the “Actions” tab.

3. Click “Control Pumps.”



Adding Medium

NOTICE If medium is in the bag and the level sensing line is disconnected and not clamped, medium will flow back through the line. Be sure to read the “Level sensing line” notice on page 21. If the harvest line is not clamped, medium will flow past the harvest valve and into the harvest line.

To add medium:

1. Check for creases in the bag. If any need to be fixed, open the door, rearrange the bag, and close the door. Pressurize the bag by repeating the integrity test (see “Integrity Test” on page 92), and confirm the creases have been fixed. Repeat as necessary.
2. Navigate to the Pumps menu (see “Accessing the Pumps menu” on page 104).
3. If the media pump is on, click the slider to turn it off.

4. Form a sterile connection between an unused medium addition line (one orange band) and the medium bottle/bag source, by welding the tubing or using the connectors.
5. Install the silicone section of the tubing in the media pump so the arrow points toward the tubing between the pump and bag (see “Using the Pumps” on page 99).
6. Adjust the media pump RPM using the up and down arrows.
7. Click the slider to turn the media pump on.
8. Click the slider to turn the media pump off after adding desired amount of medium.

Priming the Harvest Line

After adding medium, the air in the harvest line should be displaced with medium. This prevents a vacuum effect from taking place as the harvest valve moves through settled cells and micro carriers, which would cause them to enter the harvest line.

1. Confirm the harvest line is clamped.
2. Stop Agitation.
3. Partially engage the harvest valve (see “Harvesting a Run” on page 119 and follow the relevant instructions). Medium will enter the harvest line and displace the air inside.
4. Return the harvest valve to its fully disengaged starting position (see “Check Harvest Valve Alignment with Harvest Mode” on page 89 and follow the relevant instructions).

Level ‘Span’ Calibration

Level ‘Span’ Calibration with the Hello UI:

Note: This should only be performed if the Level reading reported by the software is significantly different from the actual volume in the bag.

1. Confirm the level sensing line and pressure sensing line are connected to the PBS-15/80 and are not clamped or kinked.
2. Confirm the Vertical-Wheel® Impeller is at least half-covered by medium, the bag is completely depressurized, no gases are flowing, agitation is off, and the pressure PV is 0 (re-calibrate the pressure sensor, if necessary).
3. Navigate to the “Actions” tab.
4. Click “Calibrate.”

5. Click “Level.”
6. Click “Span.”

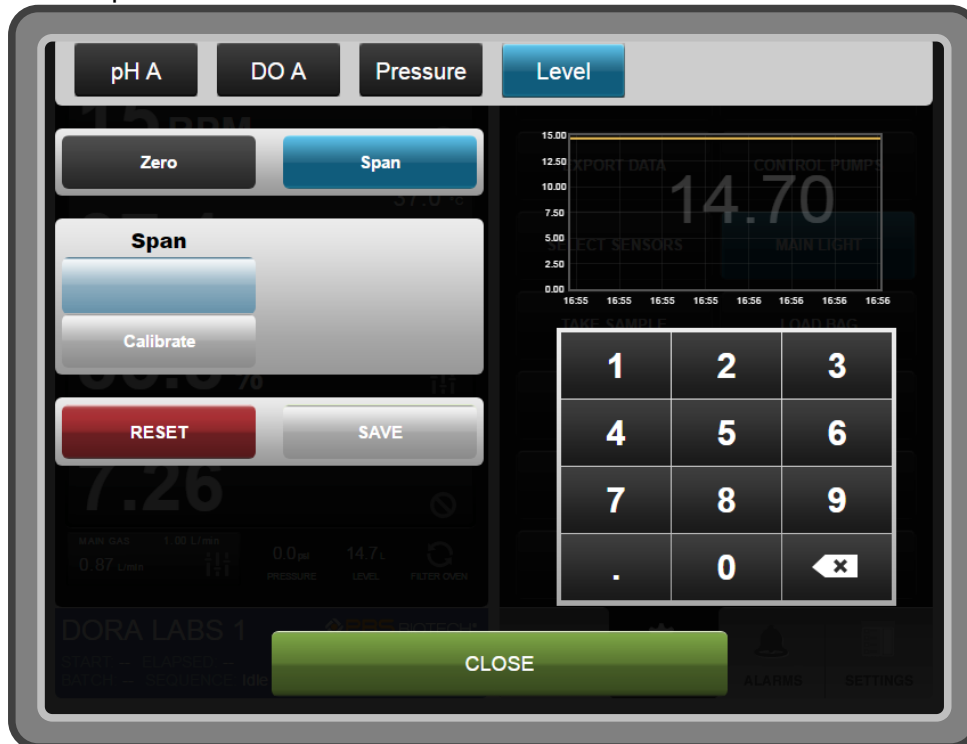

7. Enter the actual level.
8. Click the “Calibrate” button.
9. Click “Save.”
10. Click “Close.”

Note: A ‘Span’ calibration cannot be performed if the Vertical-Wheel® impeller is less than half covered.

Turning Controls On

After filling the bag with medium, the controls need to be turned on, to condition the medium. This accomplishes 3 things: (1) it allows the DO and pH sensors to polarize and equilibrate, so ‘span’/‘one-point’ calibrations can be performed, (2) it brings the PVs to within the appropriate ranges for the cell process, and (3) it acts as a sterility hold, so operators have the opportunity to determine whether the medium has been contaminated before inoculating.

First, the agitation, temperature, and main gas controllers must be turned on. Then, the DO and pH controllers can be set to Manual mode, to achieve the desired process parameters you intend to use before inoculating. For an explanation why it is recommended to use DO and pH in Manual mode rather



than Auto mode before the ‘span’/‘one-point’ calibrations are performed, see “Pre-Calibration Medium Conditioning Strategy” on page 159.

To control the DO in Manual mode, first remember that the DO is scaled so 100% equals atmospheric O₂ conditions. The amount of air entering the bag and therefore saturating the medium can be displaced with either CO₂ or N₂. For example, to control to a DO PV of 50% with pH set to 5% CO₂, set N₂ to 45% and O₂ to 0%.

To control the pH in Manual mode, set Base to 0% and CO₂% to the value that will provide the desired pH, using the “NaHCO₃, CO₂%, and pH at 37 °C” chart on page 149.

Using controls:

1. Click one of the dashboard buttons (“Agitation,” “Temperature,” “Dissolved Oxygen,” “pH,” or “Main Gas”).
2. Select a mode (Auto, Manual, or Off).

Mode Symbols	
Auto	
Manual	
Off	

3. If Auto mode, enter a set point using the on-screen keypad.

Auto Mode Variables and Set Point Units	
Agitation	Vertical-Wheel® Impeller Revolutions Per Minute
Temperature	Degrees Celsius (°C)
Main Gas	N/A - only Manual mode available
Dissolved Oxygen	% Air Saturation
pH	pH units

Recommended Auto Mode Set Points	
Agitation	15 – 35 RPM if Vertical-Wheel® impeller is fully submerged. 15 – 25 RPM if not.
Temperature	37 °C
Main Gas	N/A - only Manual mode available
Dissolved Oxygen Set Point	25 – 100% Dissolved Oxygen
Dissolved Oxygen Deadband	0 – 5% Dissolved Oxygen
pH Set Point*	6.8 – 7.4 pH units
pH Deadband	0 – 0.05 pH units
Filter Oven	38 °C

*The user must select a base pump from the “Control Pumps” menu for the pH base controller to operate. For more information, see “Selecting a Base Pump” on page 113.

Note: The dissolved oxygen and pH deadbands can be changed in the “Settings” tab. For more information, see “Settings/System Variables” on page 134.

4. If Manual mode, enter a controller output using the on-screen keypad.

Note: Other than setting DO and pH to Manual mode before the first ‘span’/‘one-point’ calibrations can be performed, Manual mode is for advanced users ONLY. It is rarely necessary to operate outside of Auto mode, except in the case of the main gas controller, as it has no Auto mode. A broken sensor may also necessitate using manual mode until the issue can be resolved, potentially after the cell culture run. Contact

PBS Biotech Technical Support for assistance.

Manual Mode Variables and Controller Output Units	
Agitation	Motor % power
Temperature	Main heater % duty
Main Gas	Total gas liters per minute
Dissolved Oxygen – N₂	Total gas % N ₂ composition
Dissolved Oxygen – O₂	Total gas % O ₂ composition
pH – CO₂	Total gas % CO ₂ composition
pH – Base	Base pump % duty

Note: When switching from Manual mode to Auto mode, the controller output will gradually increase or decrease to transition from the user-selected output in Manual mode to the PID-calculated output.

5. Click “Save.”
6. Observe that the dashboard button shows the selected mode and set point or controller output.

‘Span’/‘One-Point’ Calibrations After Equilibration

After the medium has been conditioned and the temperature, DO, and pH have equilibrated, PBS Biotech recommends performing ‘span’/‘one-point’ calibrations on the DO and pH sensors. It is recommended to calibrate the DO sensor first, because calibrating the pH sensor requires taking a sample, and clearing the sample line with air can temporarily change the DO PV.

‘One-point’/‘Span’ DO calibration:

The following is recommended for DO calibrations:

- Only perform a ‘one-point’/‘span’ DO calibration before inoculating with cells
- Perform the ‘one-point’/‘span’ DO calibration using the headspace gas composition as the reference, rather than the measured DO of a sample
- Do not perform additional DO calibrations of any type during a cell culture run

For an explanation, see “Dissolved Oxygen” on page 162.

1. Confirm sensor is fully polarized.
2. Confirm DO present value has stabilized.
Note: If the medium is 100% air saturated, the DO PV should be between 80% and 120% before performing 'one-point'/'span' calibration.
3. Navigate to the "Actions" tab.
4. Click "Calibrate."
5. Click "DO A."
6. Click "One-point."



7. Enter the correct DO PV in the 'Span' field. If the only gas flowing into the bioreactor was air, then the medium is 100% air saturated. Otherwise, before inoculating, the DO PV should equal $100 - \text{CO}_2\% - \text{N}_2\%$.
8. Click the "Calibrate 1" button.
9. Click "Save."
10. Click "Close."
11. Set DO to Auto mode, if desired (see "Turning Controls On" on page 107).

'One-point' pH calibration:

It is recommended to do this before inoculating with cells, and regularly throughout a cell culture run to counteract the pH sensor drift.

1. Take a sample (see “Take Sample” on page 116, “Take Sample” on page 171, and “Sampling for pH Measurement” on page 172). Note pH present value when taking sample.
2. Measure the pH of the sample (see “Sampling for pH Measurement” on page 172).
3. Navigate back to the “Actions” tab.
4. Click “Calibrate.”
5. Click “One-point” if it is not already selected.



6. Click “Get Vessel Temp.”
7. Enter [(pH PV) – (pH PV when taking sample) + (actual pH of sample)] in the ‘Zero’ field.
8. Click the “Calibrate 1” button.
9. Click “Save.”
10. Click “Close.”
11. Set pH to Auto mode, if desired (see “Turning Controls On” on page 107 and “Selecting a Base Pump” on page 113).

Selecting a Base Pump

PBS Biotech Technical Support recommends configuring the base pump after performing a one-point calibration on the pH sensor and adding cells.

Because pH is usually regulated exclusively by CO₂, base should only be added if absolutely necessary.

The pH controller is configured to expect a solution of 0.5 M of NaHCO₃.

To select a base pump:

1. Set pH to “Off” mode.
2. Navigate to the Pumps menu (see “Accessing the Pumps menu” on page 104).
3. Click the drop-down menu beneath “Base Pump” and select “None.”
4. If the desired base pump (Addition A or Addition B) is on, turn it off.
5. Form a sterile connection between the Addition A (one brown band) or B (one gray band) line and the base bottle/bag source, by welding the tubing or using the connectors.
6. Install the silicone section of the addition line in the corresponding addition pump (A or B) to allow the base to flow into the bag as the pump rotates clockwise (see “Using the Pumps” on page 99).
7. Confirm that the tubing is not clamped.
8. Set the addition speed to “Slow.”
9. Turn the addition pump on to prime the line.
10. Turn the addition pump off when tubing is primed.
11. Click the drop-down menu beneath “Base Pump” and select the desired addition pump.
12. Select the desired pH mode and set point or controller outputs.

Adding Additional Fluids

It may be necessary to add other fluids throughout a run, such as antifoam solution to control the amount of foam in the bag. Users can either add additions all at once, or slowly titrate them over a period of time.

To add additional fluids:

1. Navigate to the Pumps menu (see “Accessing the Pumps menu” on page 104).

2. Confirm the desired addition pump is not set to be the base pump.
3. If the desired addition pump (A or B) is on, turn it off.
4. Form a sterile connection between the Addition A (one brown band) or B (one gray band) line and the addition bottle/bag source, by welding the tubing or using the connectors.
5. Install the silicone section of the addition line in the corresponding addition pump (A or B) to allow the fluid to flow into the bag as the pump rotates clockwise (see “Using the Pumps” on page 99).
6. Confirm that the tubing is not clamped.
7. Set the desired addition speed.
8. Click the slider to turn the addition pump on.
9. Click the slider to turn the addition pump off after desired amount has been added, or leave the slider in the “on” position to continue titrating.

Load the Alarms On.alm File

After sensors have been calibrated and the important variables are within the appropriate ranges for your cell line/process, it is important to activate alarm notification before inoculating.

Alarm notification is activated by loading a different Alarms.alm file. Until this point, the Alarms Off.alm file should have been loaded. This file ignores the alarms which would be triggered while setting up for a run, such as the PVs being too low or too high before turning on controls, or the pH PV changing too rapidly during a two-point calibration. Because these alarms should not be ignored during a run, the Alarms On.alm file, or another Active alarms file that a user has configured and saved for this purpose, should be loaded at this time.

1. Confirm the Process Alarms settings for your run. Note that if a setting is configured such that the PV is outside the appropriate range, an alarm will be generated immediately after loading the Alarms On.alm file. For more information, see “Settings/System Variables” on page 134.
2. Load the Alarms On.alm file, or other desired Active file a user has configured and saved for this purpose. For more information, see “Configuring Alarm Settings” on page 69.
3. For how to view and acknowledge alarms, see “Alarms” on page 133.

Inoculate with Cells

When sensors have been calibrated and important variables are within the appropriate ranges for your cell line, it is safe to add the cells.

To inoculate:

1. Navigate to the Pumps menu (see “Accessing the Pumps menu” on page 104).
2. If the media pump is on, click the slider to turn it off.
3. Form a sterile connection between an unused medium addition line (one orange band) and the cell bottle/bag source, by welding the tubing or using the connectors.
4. Install the silicone section of the tubing in the media pump so the arrow points toward the tubing between the pump and bag (see “Using the Pumps” on page 99).
5. Check that the tubing clamp is open, and its branched tubing clamp is closed, if applicable.
6. Click the slider to turn the media pump on.
7. Click slider to turn the media pump off after adding cells.

Entering Batch Name**To name a batch:**

1. Navigate to the “Actions” tab.
2. Click “Batch.”



3. If a batch is running, end it:
 - (a) Click “End Batch.”
 - (b) Confirm by clicking “End” in the overlay.
 - (c) Click “Batch.”
4. Use the on-screen keyboard, or an external keyboard, to enter a batch name 16 characters or less.
5. Click the on-screen keyboard’s “Hide” button.
6. Click “Start Batch.”
7. Confirm by clicking “Start” in the overlay.
8. Observe that the Information Bar now displays the entered batch name, the start time, and the elapsed time.

Take Sample

For information about concerns when taking a sample, handling the sample, and measuring a sample, see “Take Sample” on page 171.

The following sub-sections are not exhaustive, and there are likely many additional ways for operators to take a sample out of the bioreactor without compromising the sterility of the bag.

PBS-15/80 bag’s sample line

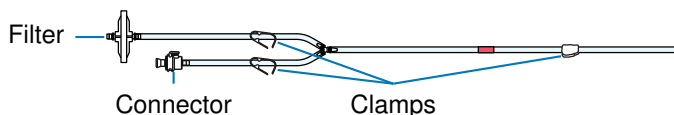

To take a sample with the bag’s sample line and a pump:

Using a pump to take a sample can decrease the sampling variability between operators. It can also, however, expose the sample to more shear stress.

Note: Proximity to a BSC is required for this procedure.

Note: This assumes the sample line is connected to a small (250 mL – 500 mL) transfer flask, i.e. one with a short dip tube.

1. Log in to the Hello UI.
2. Navigate to the “Actions” tab.

- Click “Take Sample.”

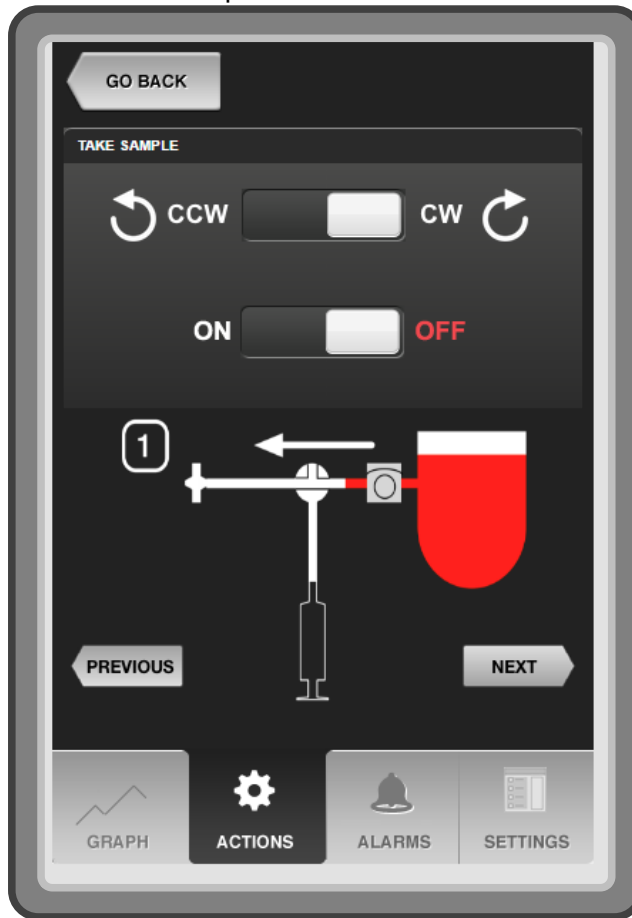

- Configure the sample pump to run clockwise (CW). Do not turn it on yet.
- Install the sample line's section of tubing between the filter and the Y-connector in the sample pump so the filter is to the left.
- Open the clamp on the sample line's section of tubing between the filter and the Y-connector.
- Put 2 50 mL conicals in the biosafety cabinet. Label one for 'Waste' and the other for 'Sample.'
- Put the transfer flask at the end of the sample line in the biosafety cabinet.
- Remove the transfer cap and hold its dip tube over the 'Waste' conical.
- Open the clamps on the sample line's section of tubing between the bag and the Y-connector, and the section of tubing between the transfer flask and the Y-connector. Liquid will flow due to gravity.
- After 5 mL or more has gone into the 'Waste' conical, re-clamp the sample line's section of tubing between the bag and the Y-connector, and

the section of tubing between the transfer flask and the Y-connector. This clears the line of settled microcarriers and excess media.

12. Hold the transfer cap's dip tube over the 'Sample' conical.
13. Open the clamp on the sample line's section of tubing between the transfer flask and the Y-connector.
14. Confirm the sample pump is configured to run clockwise, then start the pump to aliquot the sample.
15. Once the line is clear, stop the pump and clamp the section of tubing between the transfer flask and the Y-connector. The sample should be 20-30 mL, depending on the length of the sample tubing.
16. Install the transfer cap back in the transfer flask.
17. Open the clamp on the section of tubing between the bag and the Y-connector, and turn on the sample pump to clear the line.
18. Run the pump until bubbles come out of the sample port in the bag.
19. Once the line is clear, stop the pump, close all clamps, and remove the section of tubing from the sample pump.

Exchanging Medium

1. Form a sterile connection between the harvest line and the waste media bottle/bag destination by welding the tubing or using the sterile connectors.
2. Load the Alarms Off.alm file (see "Load the Alarms On.alm File" on page 114).
3. Turn temperature off, and wait 2 minutes before turning agitation off (below). This is to allow the heater plate(s) to cool before cells settle on it.
4. Change DO and pH from Auto mode to Manual mode, setting the requested N₂, O₂, and CO₂ flows to match what was called for while in Auto mode.

Users should continue to request gas flow while removing medium from the bag to maintain a reasonable amount of pressure within the bag. This will prevent the top corners of the bag from collapsing inward due to the sudden drop in pressure that may occur if medium is removed rapidly.

5. Turn agitation off.
6. Sparging gas will interfere with the cells settling to the bottom of the bag. Clamp the Micro-gas line and level sensing line as close to the bag as possible, then disconnect both the Micro-gas connector and level sensing connector from the bioreactor. Be sure to read the "Level sensing line" warning on page 21. Route O₂ through the headspace.

7. Align one of the open channels in the Vertical-Wheel[®] impeller with the harvest port at the bottom of the bag, and fully activate the harvest valve (see “Check Harvest Valve Alignment with Harvest Mode” on page 89 and follow the relevant instructions).
8. Tighten the harvest valve stabilizing block to the positioning shaft with the wing nut.
9. Wait for the cells to settle to the bottom of the bag.
10. Check that the harvest line tubing clamp is open, and its branched tubing clamp is closed, if applicable.
11. Remove the desired amount of spent medium, either by gravity or by installing the silicone section of the tubing in an external pump. Remove the tubing from the external pump when finished, if applicable.
12. Clamp the harvest line and loosen the stabilizing block from the positioning shaft using the wing nut.
13. Disengage the harvest valve and leave harvest mode (see “Check Harvest Valve Alignment with Harvest Mode” on page 89 and follow the relevant instructions).
14. Follow the instructions in the “Level sensing line” warning on page 21 to reattach the Micro-gas line and level sensing line and open the clamp.
15. Add fresh medium (see “Adding Medium” on page 105).
16. Turn agitation back on, and set DO and pH to the original desired modes.
17. When settled cells/aggregates/microcarriers are resuspended, turn temperature back on.
18. Load the Alarms On.alm file (see “Configuring Alarm Settings” on page 69 and follow the relevant instructions).

Note: If performing multiple medium exchanges, reposition tubing through the pump head if it starts to wear out in order to pump with a fresh section of tubing.

Harvesting a Run

To harvest:

1. Load the Alarms Off.alm file (see “Load the Alarms On.alm File” on page 114).
2. Set all control modes to Off.
3. Form a sterile connection between the harvest line and the harvest bottle/bag destination by welding the tubing or using the sterile connectors.

4. Loosen the stabilizing block from the positioning shaft, partially engage the harvest valve by raising it slightly above the harvest port (as shown below), and then tighten the stabilizing block to the positioning shaft.

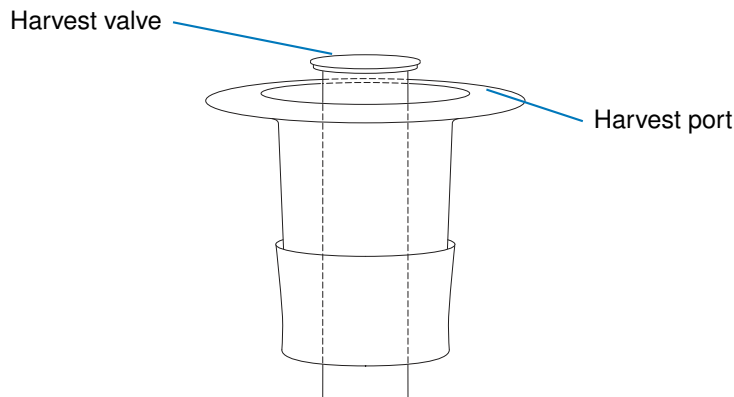

5. Check that the tubing clamp is open, and its branched tubing clamp is closed, if applicable.
6. Remove the entire bag contents, either by gravity or by installing the silicone section of the tubing in an external pump. Remove the tubing from the external pump when finished, if applicable.
7. Turn off all pumps.
8. Set base pump to “None.”
9. Turn off the light, if it is on.
10. End batch (see “Entering Batch Name” on page 115).
11. Go to the “Actions” tab and click “Unlock Door.”
12. Remove the bag.

NOTICE When removing the DO and pH sensors from the bag, be sure to retrieve the black o-rings necessary for sealing and keep them with the sensors (they can slide off and remain in the sensor ports and be accidentally disposed of).

13. Turn the filter oven off, if desired (see “Filter Oven” on page 121).
14. Clean/decontaminate the PBS-15/80 (see “Cleaning and Decontamination” on page 48).

Note: No door interlocks may be in place after harvesting if the user wishes to open the door (see “Interlocks” on page 159).

Other Features

Filter Oven

The Filter Oven heats the exhaust filter on the bag, preventing moisture from accumulating in it and clogging it. The PBS-15/80 is designed to always have the Filter Oven in Auto mode, at 38 °C. If users still want to turn it off between runs, they need to make sure to turn it on before adding medium. PBS Biotech Technical Support does not recommend this, as there is no software alert or interlock to alert users that the Filter Oven is Off.

To change the filter oven mode:

1. Log in to the Desktop UI and select the “Graph” button.

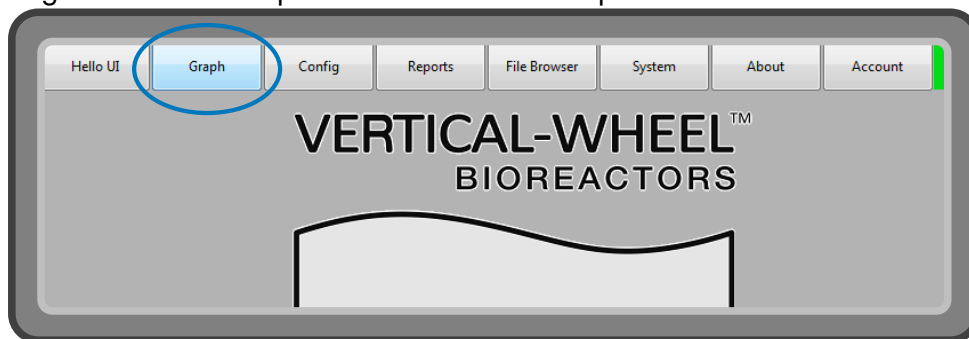

2. Click the “FiltOven” button to navigate to the Filter Oven graph page.

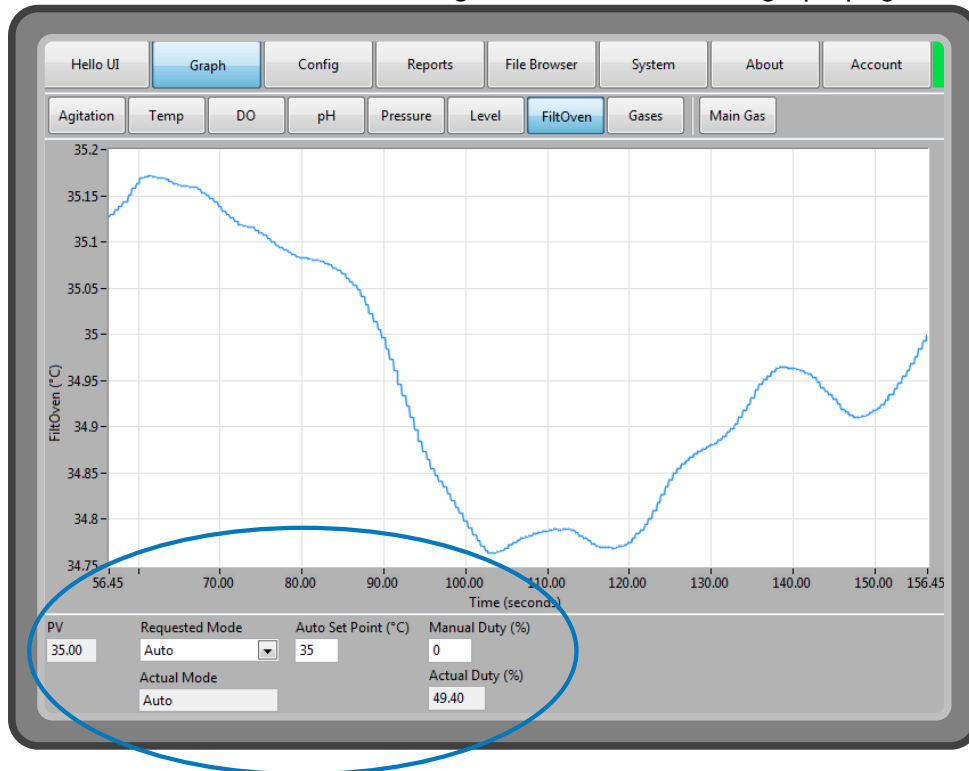

3. Select the desired mode from the ‘Requested Mode’ field.

4. To change the set point for the Filter Oven, select the 'Auto Set Point (C)' field. In the number pad that appears, enter an acceptable set point.

Recipes

NOTICE Do NOT edit the "Integrity Test" recipe without consulting PBS Biotech Technical Support.

Creating or editing recipes

1. Log in to the Desktop UI with a user account with the "Recipe Editor" permission (for more information on user permissions, see "User Group Permissions" on page 176).
2. Select the "Config" tab, then select "Recipe."

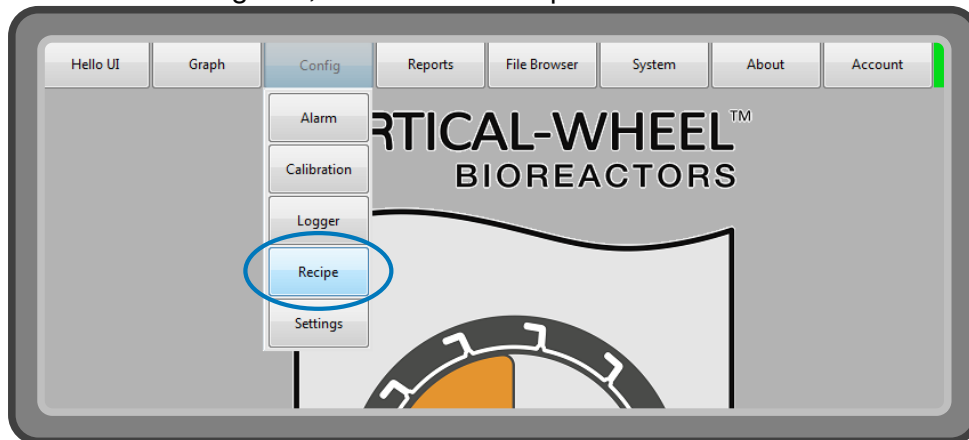

3. To edit an existing recipe, click on the recipe in the "Recipe List." To add a new recipe, click "Add."

- The on-screen keyboard will appear, allowing you to name your new recipe. (Please note that the use of capital letters in the recipe name will not be reflected in the Hello UI). An existing recipe name may be edited at any time by selecting the recipe and clicking the "New Recipe Name" field.

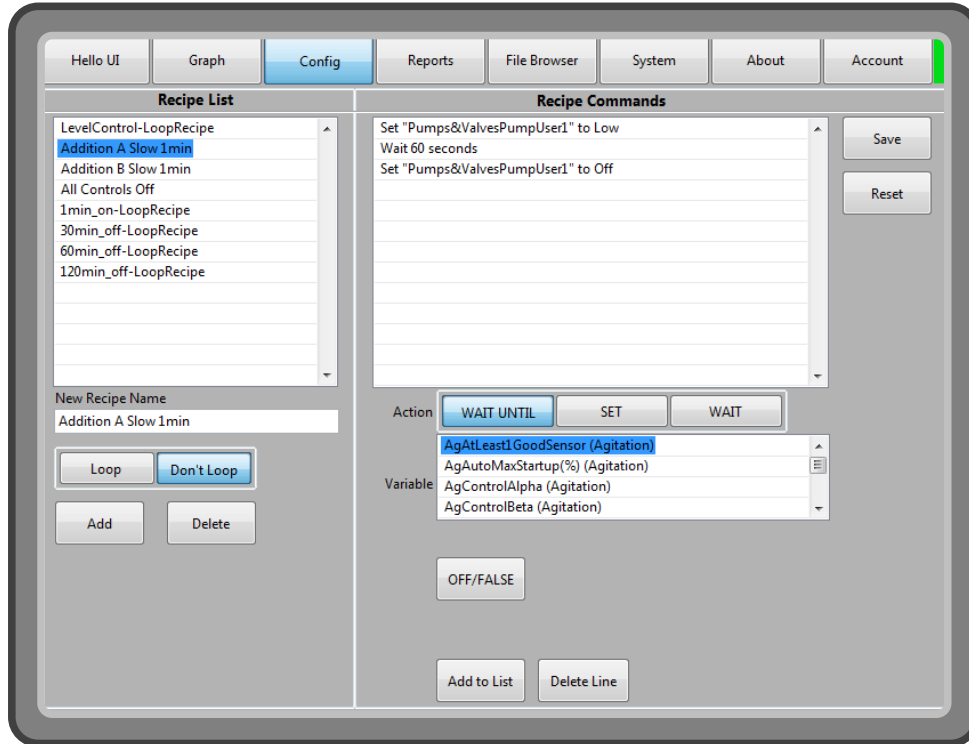

Configuring recipes

- Select a recipe in the "Recipe List" field.
- Recipe steps will be listed in order of operation in the "Recipe Commands" field. In a new recipe, this field will be blank.
- To add a recipe step, select a variable in the "Variable" field, then select one of the buttons in the "Action" field (for more information on the variables listed, see Appendix 4 on page 224).
- Select or enter the relevant data for the step, then click "Add to List."
- To delete a step, click "Delete Line."
- To rearrange steps, click and drag them.
- To revert a recipe, click "Reset."
- When you are finished configuring your recipe, click "Save."

Running recipes

- Log in to the Hello UI.

2. Navigate to the “Actions” tab.
3. Click “Auto Pilot.”
4. Click “SELECT RECIPE” and select the desired recipe.
5. Click the green “Start” button.

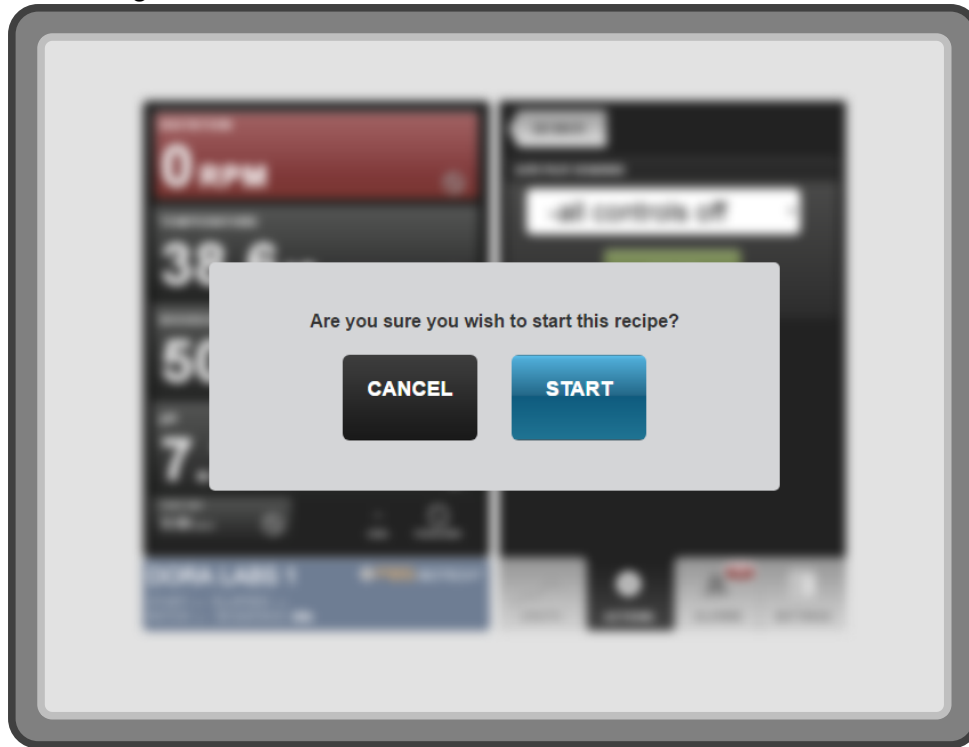

6. Click “Start” to confirm.

Note: If the Auto Pilot menu was open when a new recipe was created, close and re-open the menu by clicking “Go Back” and then “Auto Pilot.”

For more on recipes, see “Recipes” on page 167.

Manually Archiving DBs

The PBS Software automatically archives the active database based on its size. It checks every hour, and when a user stops a batch. However, if users desire, they can manually archive the active database.

1. Log in to the Desktop UI with a user account with the “DB Management” permission.

2. Navigate to the File Browser menu.

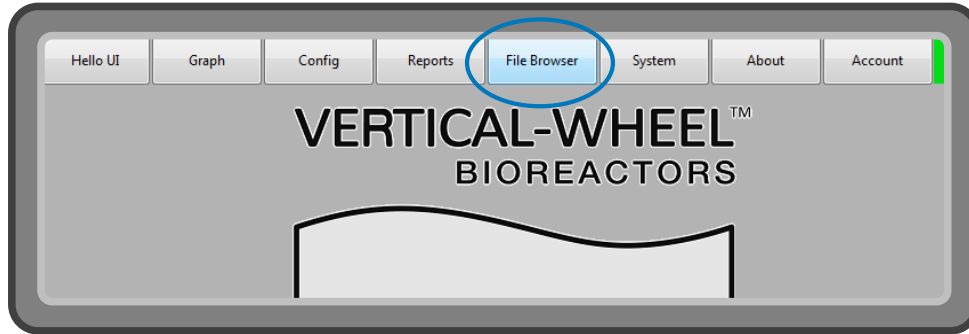

3. Click the "Archive DB" button.

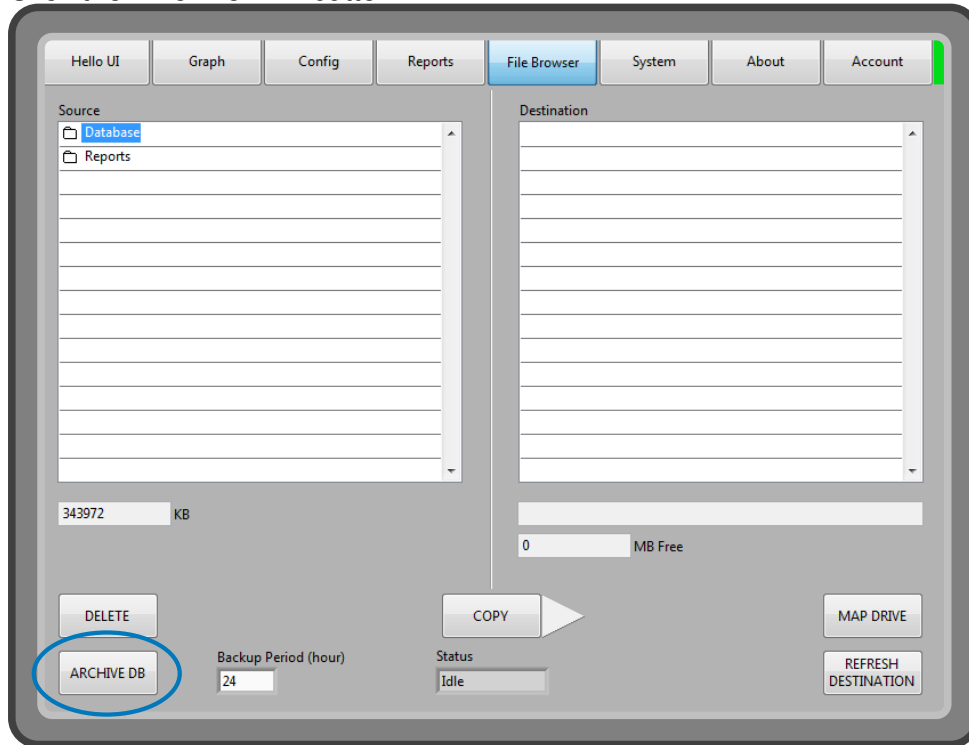

Note: During the archive process, data recording is paused, and restarts after the archive process is complete. The data generated during this time is not lost, but is temporarily stored in memory. Access to all features is also restored once the archive process is complete. For more information on the archive process, see "Database" on page 171.

Managing Files

To copy databases and reports to external drives, and delete reports and archived databases, see "Generating Reports" on page 126. Users should only have to delete archived databases yearly. DO NOT delete archived databases until they have been securely backed up.

Generating Reports

Reports can be generated in both the Desktop and Hello User Interfaces.

NOTICE The reports are generated in .csv format. Because many spreadsheet applications, such as Excel, have limited .csv functionality (they may not save the timestamp values properly in a .csv file, for example), once users open the .csv file in their preferred spreadsheet application, they should “Save As” an application-specific file type (e.g. .xls), and graph and analyze the data in that file rather than in the .csv file.

To generate reports from the active database with the Hello UI (preferred method):

1. Log in to the Hello UI and navigate to the “Actions” tab.
2. Click “Export Data.”
3. Choose a batch or time span:

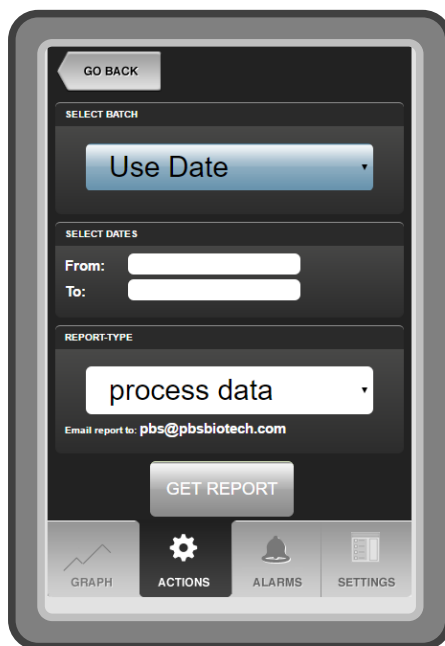

- (a) To select a batch by name, use the “Select Batch” dropdown menu.

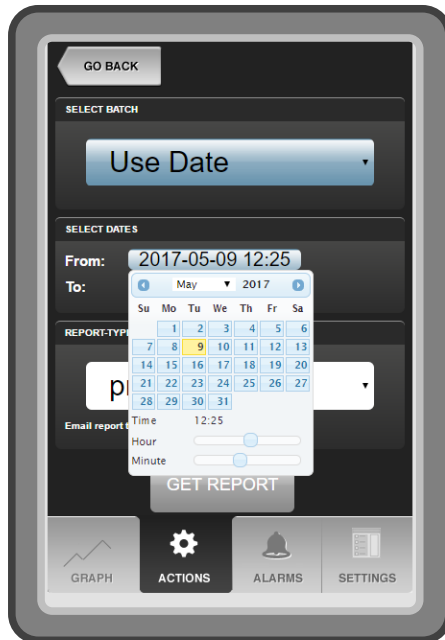

- (b) To select a time span, click the 'From' field, choose the dates in the calendar, and use the sliders to select the hours and minutes. Click back into the Export Data window.
- (c) Click the 'To' field, and choose a date and time.

4. Select "Report Type." For more information on Report Types, see "Types" on page 169.

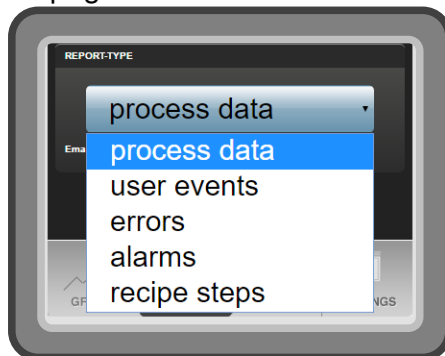

5. Verify that the email address listed is correct.



6. Click "Get Report."
7. You can click the "Open Report" button to preview the raw contents of the report.
8. To access the report file:
 - (a) If email is configured correctly, the report will be in your inbox.
 - (b) If you are accessing the PBS-15/80 from a remote client and would like to save the report directly to your computer, click the "Download Report" button to save the file. If the file's "Save As" prompt suggests .txt format, change it to .csv.

- (c) If you are working directly on the bioreactor, note the name of the report, and see the instructions below for using the Desktop UI to copy reports to external drives.

To generate reports with the Desktop UI (alternative method):

1. Log in to the Desktop UI and click the “Reports” button.

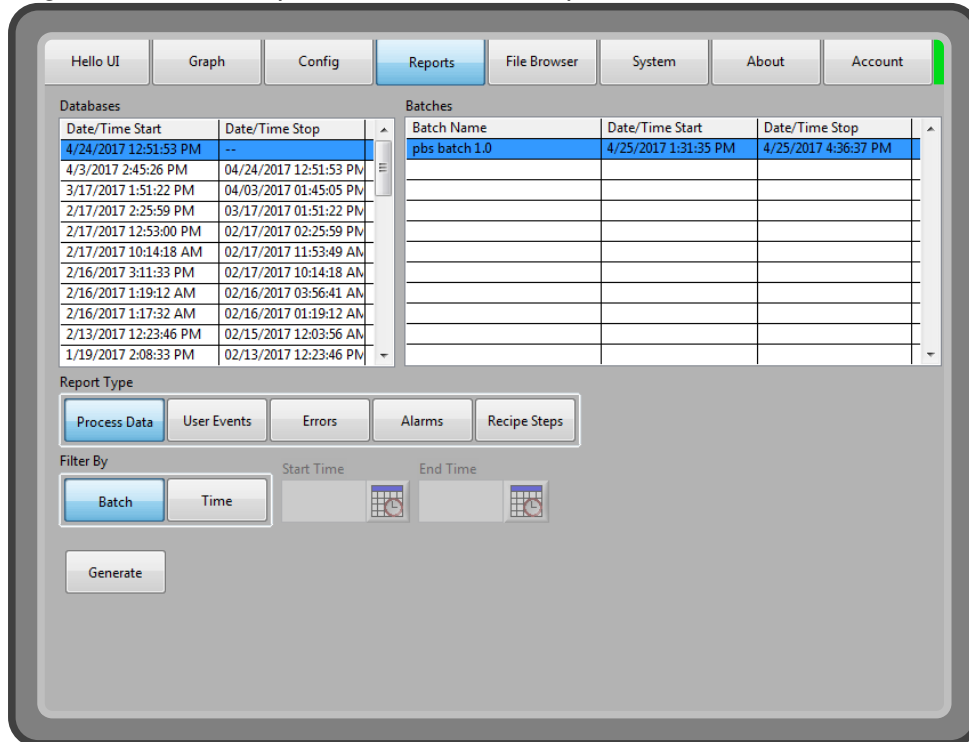

2. Select either the current database, which will be the first database listed in the “Databases” field, or an archived database listed below the current one.
3. Choose a “Report Type.”
4. Select whether you want to filter by “Batch,” or “Time.”
 - (a) If selecting “Batch,” then choose a batch from those listed in the “Batches” field.

- (b) If selecting “Time,” then select the calendar button beside the ‘Start Time’ field. In the menu that appears, select a time and date. Repeat with the ‘End Time’ field.

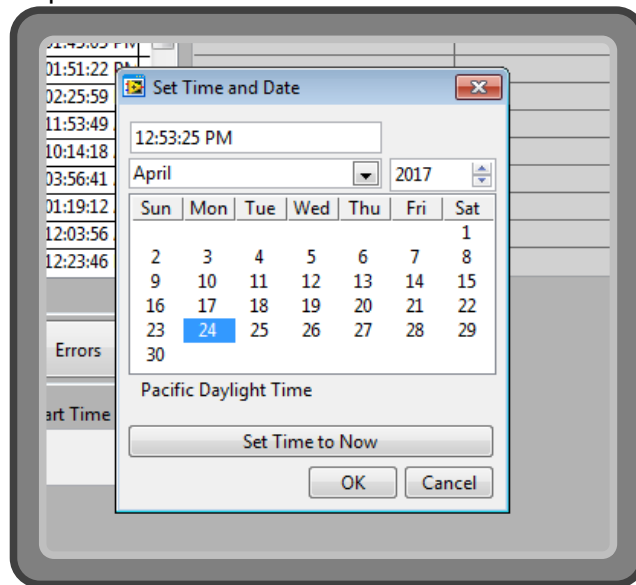

5. Click the “Generate” button.

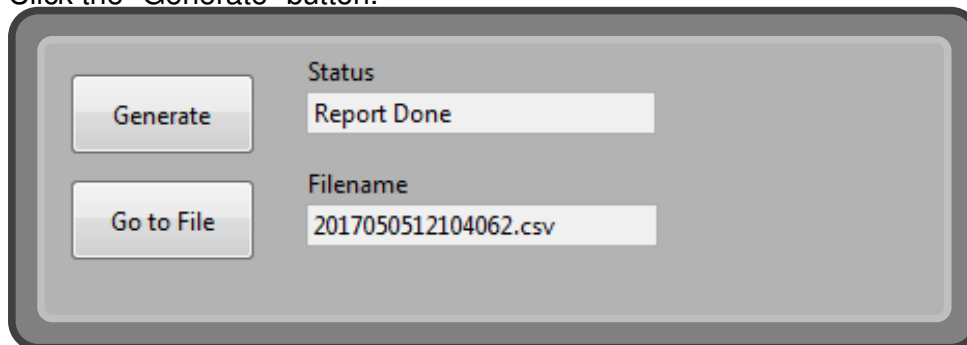

6. Wait until the 'Status' field reads 'Report Done,' then click the "Go to File" button to navigate to the "File Browser" page on the Desktop UI. Your report will appear in the 'Source' field of the File Browser page.

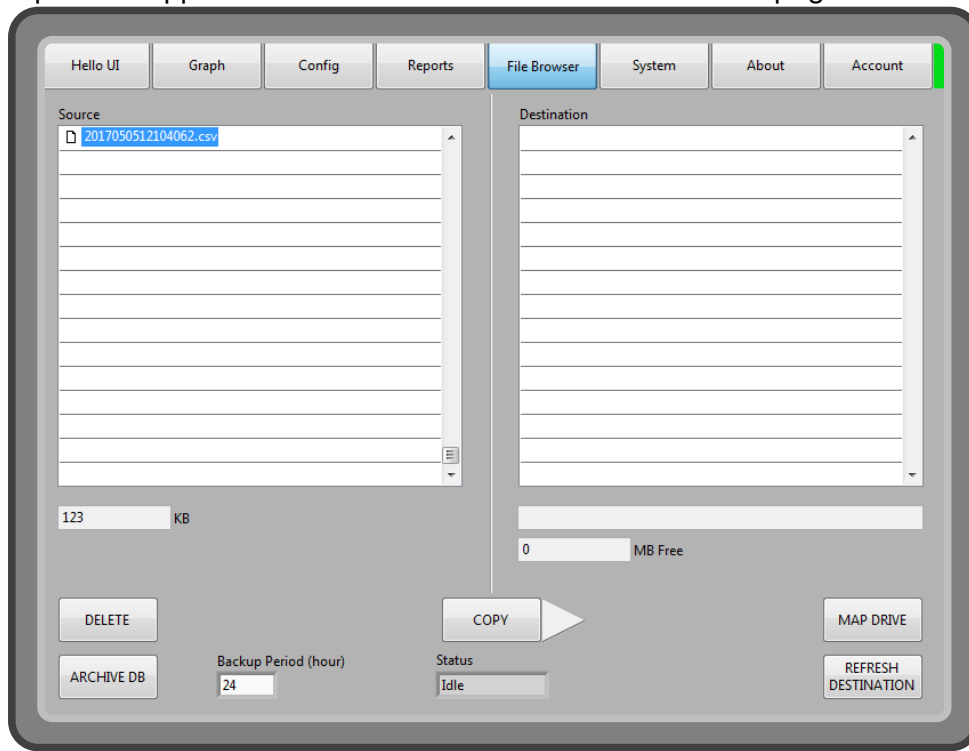

7. Any external drives, including mapped network drives, will be displayed under Destination. Navigate to the desired location, and click the "Copy" button to copy the file to it. Other reports, besides the last one generated, can also be copied to external media. After copying, reports can be deleted. Users may also navigate in the 'Source' field to the Database folder, where they may copy any of the contents, or delete databases which have been archived. Users should not delete archived databases until they have been securely backed up.

Light

To use the light with the Hello UI:

1. Navigate to the “Actions” tab.
2. Click “Main Light” to turn the light on. The button will change from black to blue.

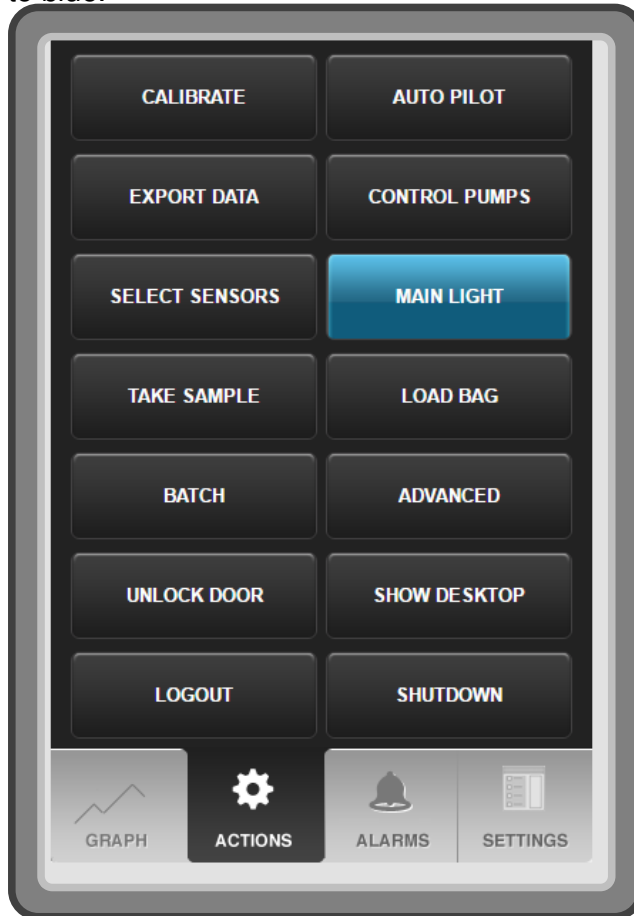

3. Click “Main Light” to turn the light off. The button will change from blue to black.

Advanced View

In addition to all the data displayed in the Dashboard and button functions, the Advanced View menu also displays the Controller Outputs for each controller, and the filter oven temperature. The Controller Output column shows the controller output being requested by the software for each controller. The actual flow rates for each MFC are reported in the row at the bottom of the menu. For example, if the user requests 50% N₂ flow but there is no source pressure to the N₂ MFC, the Dissolved Oxygen Controller Output will show 50% N₂, but the N₂ MFC flow will show 0 L/min.



	Mode	PV	Set Point	Controller Output	ALERT
Agitation	🔄	25 RPM	25 RPM	42.5 %	----
Temperature	🚫	35.5 °C	----	0.0 %	----
Dissolved Oxygen	📊	41.1 %	O2: 0.0 % N2: 60.0 %	O2: 0.0 % N2: 60.0 %	----
pH	🔄	0.00	7.20	BASE%: 0.0 % CO2: 6.3 %	BROKEN
Main Gas	📊	N/A	0.85 L/min	0.85 L/min	----
Filter Oven	🔄	38.1 °C	38.0 °C	50.0 %	----
Level	N/A	13.63 L	N/A	N/A	----
Pressure	N/A	0.0 psi	N/A	N/A	----
Gas Flow (L/min)	Air: 0.29	N2: 0.51	CO2: 0.05	O2: 0.00	

DORA LABS 1 ALARM

CLOSE

Show Desktop

This button can be used to navigate to the Desktop UI.

Shutdown

Users can shut down the HMI computer from the Hello UI or from the Desktop UI. Note that the RIO controller will continue running as long as the PBS-15/80 has power. Because there is no “On” switch on the PBS-15/80, it is recommended that the HMI is only shut down after turning off all controllers, and when the PBS-15/80 is going to be unplugged and stored. After performing a clean shutdown, the HMI can be restarted by reconnecting power to the bioreactor.

The following power-off procedure **MUST** be used when removing power:

1. Initiate Shutdown from the Shutdown menu in the Hello UI. If the PBS Software is not running, shutdown can be initiated from the Start Menu instead.
2. Wait for the software to shutdown and display “No Signal” (or similar) on the monitor.
3. Wait an additional 10 seconds (or longer).
4. Unplug the power cord.

NOTICE Unplugging the bioreactor without following the correct power-off procedure risks corrupting files that are critical for bioreactor system operation, including loss of historical data and user account information.

Alarms

To acknowledge alarms:

1. Navigate to the “Alarms” tab.
2. If you would like to acknowledge one alarm:

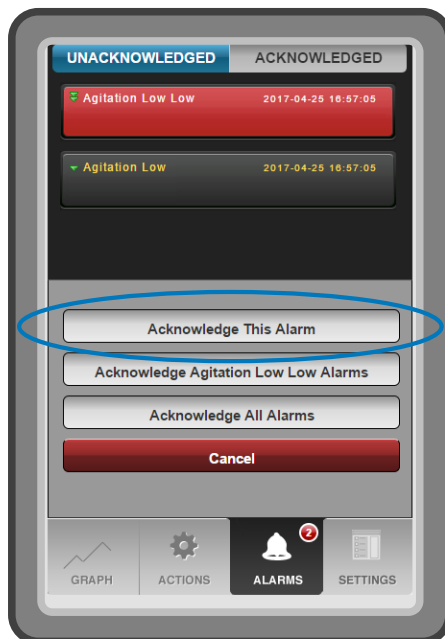

- (a) Click the alarm.
- (b) Click “Acknowledge This Alarm.”
- (c) The alarm disappears from the “Unacknowledged” list and appears in the “Acknowledged” list. The alarm now also includes which user acknowledged it and when.

3. If you would like to acknowledge all alarms of one type:



- (a) Click one alarm of that type.
- (b) Click “Acknowledge <Alarm Name> Alarms.”
- (c) All alarms of that type disappear from the “Unacknowledged” list and appear in the “Acknowledged” list. The alarms now also include which user acknowledged them and when.

4. If you would like to acknowledge all alarms:

- (a) Click any alarm.
- (b) Click “Acknowledge All Alarms.”
- (c) All alarms disappear from the “Unacknowledged” list and appear in the “Acknowledged” list. The alarms now also include which user acknowledged them and when.

For definitions of all alarms, see Appendix 2 on page 215.

Settings/System Variables

WARNING! There are many settings PBS Biotech Technical Support does not recommend users change. For a complete list of all settings, their definitions, and whether PBS Biotech Technical Support recommends changing them, see Appendix 1 on page 188.

To change settings with the Hello UI (preferred method):

1. Log in to the Hello UI as a user with the “Hello User Interface - Hello Settings” permission.

2. Navigate to the “Settings” tab.

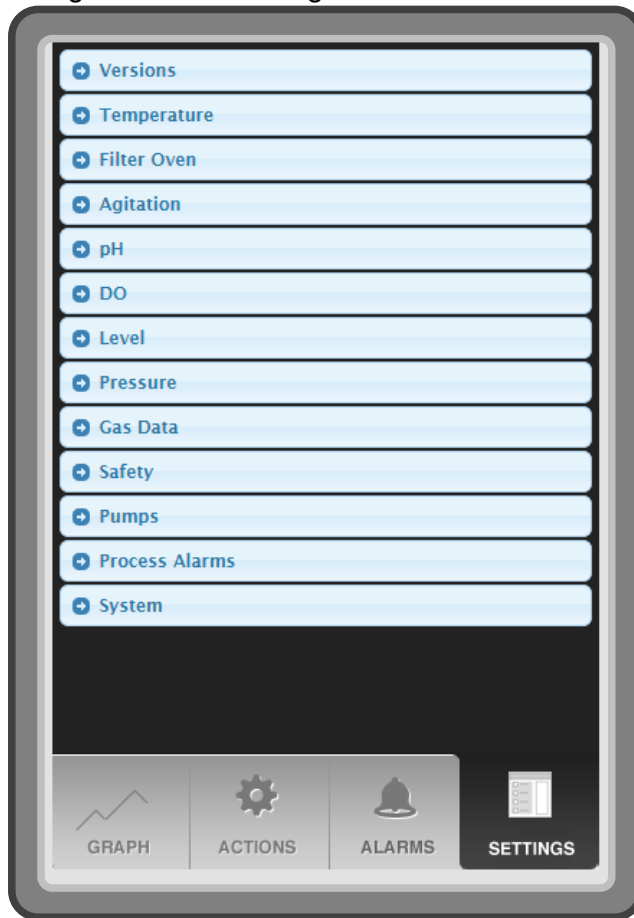

3. Click a submenu to expand it.
4. Scroll up or down and click a variable to change.
5. Use the keypad to enter a new value.
6. Click “OK.”

To change settings with the Desktop UI (alternative method):

1. Log in to the Desktop UI with an account with the “Desktop Settings – Settings Editor” permission.

2. Navigate to Config → Settings. The contents of the “active” file will be displayed, which match the file named System Variables.sys.

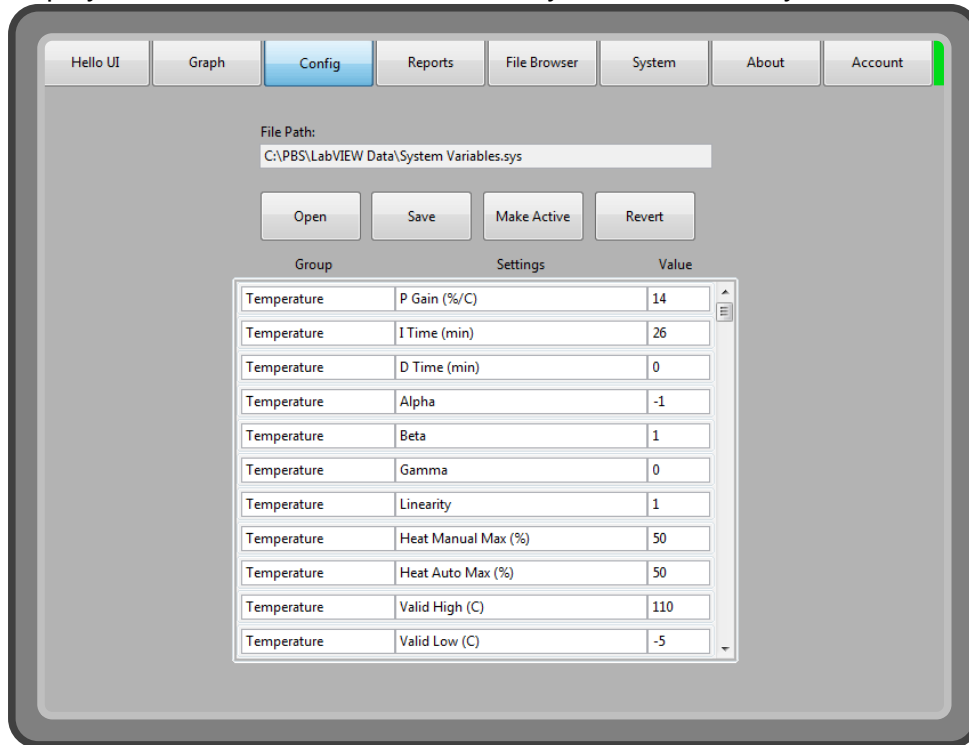

3. Click “Open” to edit an existing file, or simply begin making changes to the “active” file currently displayed.

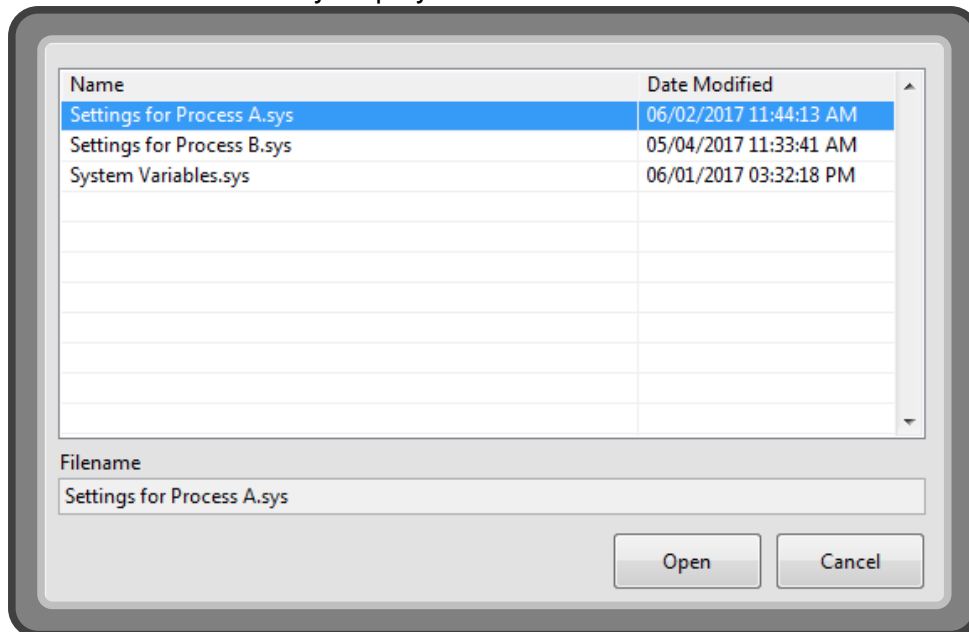

4. Select a file to edit, then click “Open.”
5. Scroll through the list and click a variable to change, then use the onscreen keyboard or an external keyboard to enter a new value.

time zone, and if they generate a report by time span, they will specify the time span in their own time zone. However, actions performed by that user and recorded to the database will be in the bioreactor's system time, as will generated reports.

Oxygen Flow Valve

For processes with high O₂ consumption rates, the O₂ transfer only through the overlay may not be enough at some point in the run. Switch to sparging O₂ when the DO controller is requesting the maximum possible O₂ flow, but the DO value is still less than the set point. To switch from flowing O₂ through the overlay to sparging:

1. Set the DO control to 'Off.'
2. Set the oxygen flow valve to "Sparger."
3. Set the DO "O2 P Gain (%/DO%)," "O2 I Time (min)," and "O2 D Time (min)" settings to the correct value for the configuration (see Appendix 1 "DO" section on page 199).
4. Set the DO control back to 'Auto' or 'Manual.'

For more information, see "Oxygen Flow Valve" on page 179.

Reboot RIO

Users should not have to reboot the RIO under normal circumstances. However, if advised to do so by PBS Biotech Technical Support or as a troubleshooting measure, the following steps should be performed:

1. Note the modes all controllers are in. For controllers in Auto mode, note the controller outputs.
2. Set all controllers to Off mode.
3. Log in to the Desktop UI as a user with the "System Management" permission.
4. Navigate to System → Tools.
5. Click the "Reboot" button under "Reboot RIO," then click "YES."
6. Wait for the RIO to finish rebooting (the "Reboot" button will no longer be grayed out).
7. When the RIO has finished rebooting, set all controllers which had been in Manual mode back to Manual mode. Set all controllers which had been in Auto mode to Manual mode, with the manual set point equal to the controller outputs noted in step 1.

8. Set all controllers which had been in Auto mode back to Auto mode.

Note: The controllers should be set to Manual mode before switching back to Auto to avoid the time lag in ramping up output.

Other Calibrations

The calibrations which users will have to perform before and during a batch run should all be performed in the Hello UI - instructions are in the sections under “Before Starting a Batch Run” on page 77, and “Starting a Run” on page 99. Additional calibration actions can be performed in the Desktop UI’s “Calibration” configuration page, but such calibrations should only be performed after consulting with PBS Biotech Technical Support. The “Advanced Calibration” user permission is required to access this page. For more information on calibrations, see “Calibrating/Configuring Sensors” on page 159.

Hello User Interface

The primary way of interacting with the PBS-15/80 is the Hello User Interface (Hello UI), which is automatically launched when the PBS-15/80 is turned on. It is served up as a website by the Hello UI server and is accessible through a web browser. Google Chrome and Safari for iOS are the only browsers supported. Because the Hello UI is a website, it can also be accessed by another computer or mobile device on the same network as the PBS-15/80.

Desktop User Interface

While the Hello UI is the primary way of interacting with the PBS-15/80, the Desktop User Interface (Desktop UI) provides supplemental functions.

Interlocks

To prevent unsafe conditions or conditions that would hinder the growth of cells, the software interlocks the controllers when certain conditions are met.

Conditions Causing Interlocks							
Interlocked Controls		Agitation	Temperature	Level	Pressure	Pressure Line Sensing	Comb Plate
	Agitation	Agitation is in Harvest Mode					Comb plate has popped
	Temperature	Agitation PV = 0 RPM and power output to the motor < "Min Ag Power (%)"	Temperature PV > "Max Temp (C)"	Level PV < "Min Level (L)" or Level PV > "Max Level (L)"			Comb plate has popped [†]
	Main Gas				Pressure PV > "Max Pressure (psi)"	Pressure sensing line is disconnected	Comb plate has popped [†]
	DO				Pressure PV > "Max Pressure (psi)"	Pressure sensing line is disconnected	Comb plate has popped [†]
	pH			Level PV > "Max Level (L)"	Pressure PV > "Max Pressure (psi)"	Pressure sensing line is disconnected	Comb plate has popped [†]
	Control Pumps			Level PV > "Max Level (L)"	Pressure PV > "Max Pressure (psi)"	Pressure sensing line is disconnected	Comb plate has popped [†]
	Door	Agitation PV > 0 RPM		Level PV > 0.001 L	Pressure PV > "Max Pressure (psi)"	Pressure sensing line is disconnected	Comb plate has popped [‡]

* The popped comb plate interlocks Agitation, which then interlocks Temperature.

† Power is cut to the MFCs and pumps, although software will not necessarily display "Interlock".

‡ This interlock is only available on bioreactors with sbRIO model 9641 or 9642 (as visible in the Desktop UI About tab).

Agitation

The agitation PV is determined by a Hall effect sensor which detects the passage of magnets on the Vertical-Wheel® impeller. The period between magnet passes is used to calculate a value in RPM. The calculation is averaged over a configurable number of samples to report an accurate, stable value.

The Vertical-Wheel® impeller is magnetically coupled to a motor in the bioreactor which controls agitation output.

The agitation controller has three user modes and one broken sensor mode:

- Off mode
- Manual mode
- Auto mode
- Lookup mode (broken sensor mode)

Off Mode

No power is supplied to the motor.

Manual Mode

User selects a power output as a percentage of the motor's maximum.

Auto Mode

User selects a set point in units of RPM. A PID controller adjusts the motor's power output to achieve a stable set point.

Lookup Mode

This is the broken agitation sensor mode. Lookup mode is triggered if too much time has passed in Auto Mode since the last magnet pass was detected. The controller assumes that the sensor has failed, and attempts to estimate the output required to achieve the set point.

The timeout can be adjusted by changing the "Lookup Mode Timeout (s)" setting, although the "Pulse Mode Timeout (s)" setting should also be modified. The power output estimation is calculated as: Set Point × "Lookup Factor (%/RPM)."

Harvest Mode

When the user clicks the “Harvest” button in the “Agitation” graph of the Desktop UI, the following events occur:

1. The Harvest Status is set to “Ramping down speed” while agitation is set to Auto mode with a set point of 0 RPM.
2. When the agitation PV is low enough, agitation is set to Manual mode at a very low output.
3. The Harvest Status is set to “Attempting to align wheel” while the software checks that a magnet passes the Hall Effect sensor.
4. If a magnet passes the Hall Effect sensor, the software continues outputting the low Manual output for the Harvest “Delay (s)” time. Otherwise, it reports that the Harvest timeout was reached.
5. The Harvest Status is set to “In Harvest Mode” while agitation is set to Off mode, and the Auto and Manual set points are restored to their original values (from when the user first clicked the “Harvest” button).

Any changes a user makes to the agitation mode or set point during this sequence of events could prevent it from completing successfully.

Output Ranges

For agitation control range, see “Agitation Control Range” on page 51.

Agitation motor power range is 0 - 100%.

Relevant Settings

See Appendix 1 on page 188 for each setting’s default value, definition, and whether users can safely change the value without consulting PBS Biotech Technical Support.

Agitation (page 191)

- P Gain (%/RPM)
- I Time (min)
- D Time (min)
- Alpha
- Beta
- Gamma
- Linearity
- Minimum (RPM)
- Pulse Mode Timeout (s)
- Lookup Mode Timeout (s)
- Lookup Factor (%/RPM)
- Power Auto Max (%)
- Power Auto Min (%)
- Auto Max Startup (%)
- Power Manual Max (%)
- Number of Magnets
- Samples to Average

Safety (page 208)

- Min Ag Power (%)

Process Alarms (page 210)

- Agitation Low Low (RPM)
- Agitation Low (RPM)
- Agitation High (RPM)
- Agitation High High (RPM)

Interlocks

The agitation motor will not turn on if the comb plate has popped.

The agitation motor will not turn on if it is in Harvest mode.

Temperature

The temperature PV, reported in degrees celsius ($^{\circ}\text{C}$), is determined by one of two temperature sensors positioned behind the bag at the back of the chamber. The software refers to them as temperature sensors "A" and "B."

The temperature controller has three user modes and one broken sensor mode:

- Off mode
- Manual mode
- Auto mode
- Broken sensor mode

Off Mode

The main heater is off.

Manual Mode

User selects a main heater duty as a percentage of its maximum power.

Auto Mode

User selects a set point in $^{\circ}\text{C}$. A PID controller adjusts the main heater duty to attempt to achieve the set point.

Broken Sensor Mode

When temperature is in Auto mode and the temperature sensor detects a PV outside the valid range, the software assumes the sensor is broken, and in its best attempt at maintaining control the software outputs the average of its

output values during the last 100 seconds before the software entered broken sensor mode.

Output Ranges

For temperature control range, see “Temperature Control Range” on page 52.

The recommended main heater duty output range is 0 – 50% for the PBS-15 and 0 – 100% for the PBS-80.

Relevant Settings

See Appendix 1 on page 188 for each setting’s default value, definition, and whether users can safely change the value without consulting PBS Biotech Technical Support.

Temperature (page 188)

- P Gain (%/C)
- I Time (min)
- D Time (min)
- Alpha
- Beta
- Gamma
- Linearity
- Heat Manual Max (%)
- Heat Auto Max (%)
- Valid High (C)
- Valid Low (C)
- Mismatch Thresh (C)

Safety (page 208)

- Min Ag Power (%)
- Max Temp (C)
- Min Level (L)
- Max Level (L)

Process Alarms (page 210)

- Temp Low Low (C)
- Temp Low (C)
- Temp High (C)
- Temp High High (C)

Interlocks

The main heater will not turn on if the agitation PV is below the Agitation “Minimum (RPM)” setting unless the power output to the agitation motor is greater than the Safety “Min Ag Power (%)” setting. This is to avoid overheating cells which settle at the bottom of the bag. The main heater will continue to heat as long as the agitation controller is outputting sufficient power, even if the Hall effect sensor fails.

The main heater will not turn on if the temperature PV is greater than or equal to the Safety “Max Temp (C)” setting. This protects the run against a broken

sensor or an improperly entered set point.

The main heater will not turn on if the level PV is below the Safety “Min Level (L)” setting. This prevents damage to the disposable or its contents when the bioreactor system cannot properly control temperature at low volumes.

The main heater will not turn on if the level PV is above the Safety “Max Level (L)” setting. This is to prevent the heater from burning any medium which would spill out of an overfull bag.

Main Gas

The main gas PV, reported in liters per minute (LPM), is determined by reading the feedback voltages from the four gas mass flow controllers (MFCs): Air, N₂, O₂, and CO₂. Main gas only has two modes: Off, where no gas flows, and Manual, where the gas flows at the rate requested by the user.

The gas flow rate ranges for the MFCs are defined in “Gas Flow Rate Range” on page 52. If the requested flow rate for an individual gas is less than the MFC’s minimum flow rate, the MFC will “pulse” its output to meet the request. The software prioritizes the gas composition to meet the pH and DO controller requests in the following order:

1. CO₂
2. O₂
3. N₂
4. Air (remainder of request)

Relevant Settings

See Appendix 1 on page 188 for each setting’s default value, definition, and whether users can safely change the value without consulting PBS Biotech Technical Support.

Gas Data (page 205)

- CO₂ Min (LPM)
- CO₂ Off (V)
- N₂ Min (LPM)
- N₂ Off (V)
- Air Min (LPM)
- Air Off (V)
- O₂ Min (LPM)
- O₂ Off (V)
- PWM On Time (s)
- PWM Max Period (s)
- Mismatch Thresh (V)
- Manual Max (LPM)

Safety (page 208)

- Max Pressure (psi)

Process Alarms (page 210)

- Main Gas Low Low (LPM)
- Main Gas Low (LPM)
- Main Gas High (LPM)
- Main Gas High High (LPM)

Interlocks

Gases will not flow if the pressure PV is above the Safety “Max Pressure (psi)” setting. This is to prevent the bag from becoming over pressurized.

Gases will not flow if the software detects that the pressure sensing line is disconnected. This is to prevent the bag from becoming over pressurized.

Dissolved Oxygen

The dissolved oxygen PV is reported as a percent of Air Saturation [(%) or (DO%)] and is determined by a DO sensor. The software refers to it as “DO sensor A.” A measurement of 100% DO does not mean the media is fully saturated with Oxygen, but instead that the media is fully saturated with Air.

The DO is controlled by varying the N₂ and O₂ gas flow as a percentage of main gas flow. The DO PV is lowered by increasing the % N₂ composition, and is raised by increasing the % O₂ composition. To understand how the software determines which gases to flow, see “Main Gas” on page 145.

The DO controller has three user modes and one broken sensor mode:

- Off mode
- Manual mode
- Auto mode
- Broken sensor mode

Off Mode

N₂ and O₂ are 0% of main gas flow.

Manual Mode

User selects N₂ and/or O₂ flow as a percentage of main gas flow.

Auto Mode

User selects a set point in units of % dissolved oxygen, which the software achieves by adjusting N₂ flow and O₂ flow. Each gas uses its own PID loop: the N₂ loop controls to the DO set point plus the DO “Deadband (DO%)” setting, and the O₂ loop controls to the DO set point minus the DO “Deadband (DO%)” setting.

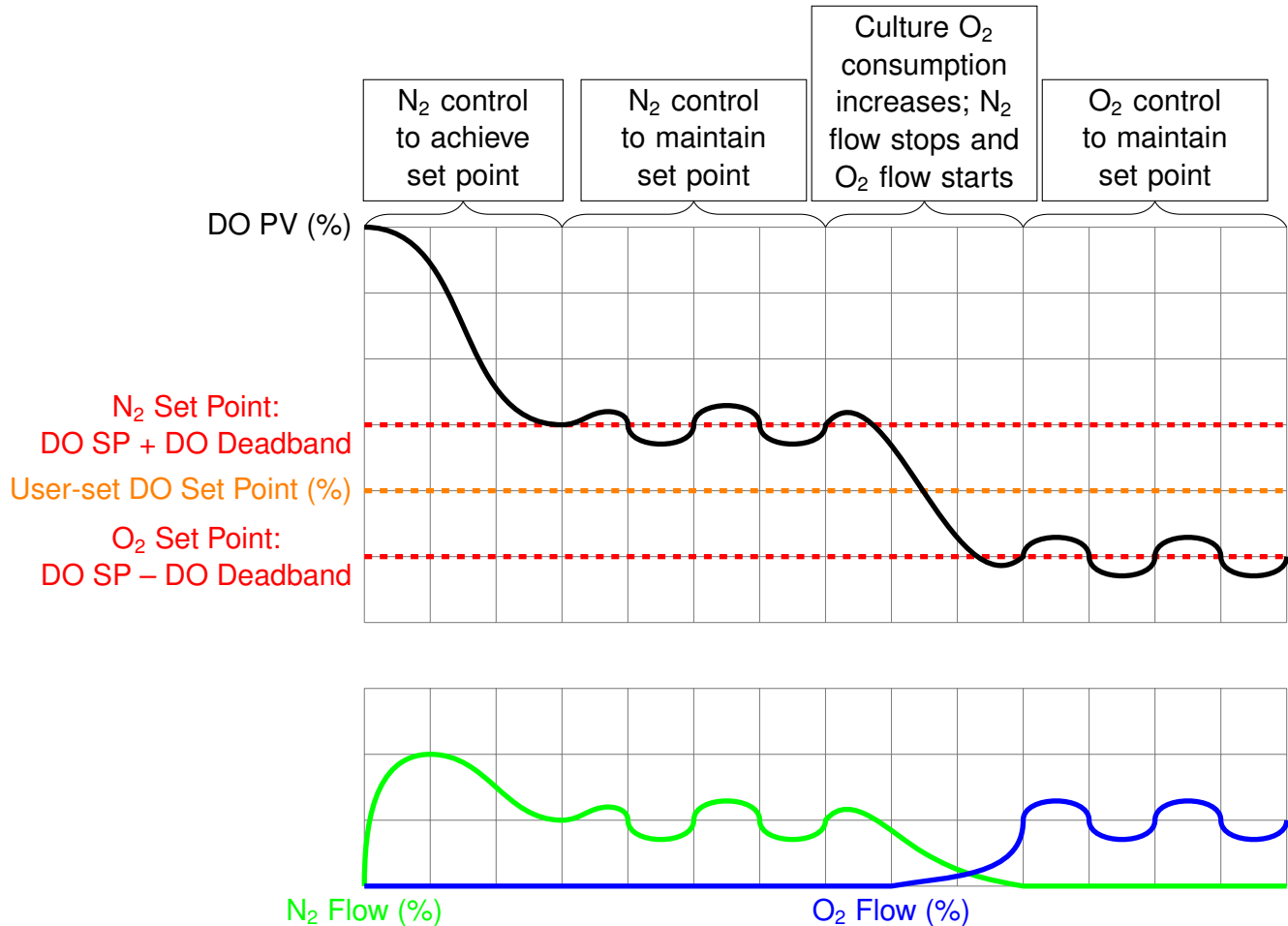

Broken Sensor Mode

When DO is in Auto mode and the DO sensor detects a PV outside the valid range, the software assumes the sensor is broken, and outputs the average of its N₂ and O₂ output values during the last 100 seconds before the software entered broken sensor mode. Note that this is only intended to preserve short term stability – users should still take appropriate action in the event of sensor failure.

Output Ranges

The recommended N₂ output is 0 - 100% of main gas flow. The N₂ MFC output is stated in “Gas Flow Rate Range” on page 52. N₂ “pulsing” at the minimum value takes effect if the N₂ % called for represents less than the MFC’s minimum flow rate.

The O₂ MFC output is stated in “Gas Flow Rate Range” on page 52. O₂ “pulsing” at the minimum value takes effect if the O₂ % called for represents less than the MFC’s minimum flow rate. The software will not request more than the O₂ MFC minimum flow until the net volume of O₂ output since turning DO on is greater than the Gas Data “O₂ Min Volume (L)” setting. This is known as the “O₂ Slow Start” feature, and is intended to prevent damage to the bag or accessories when O₂ is being sparged.

Relevant Settings

See Appendix 1 on page 188 for each setting’s default value, definition, and whether users can safely change the value without consulting PBS Biotech Technical Support.

DO (page 199)

- Valid High (DO%)
- Valid Low (DO%)
- O₂ P Gain (%/DO%)
- O₂ I Time (min)
- O₂ D Time (min)
- O₂ Alpha
- O₂ Beta
- O₂ Gamma
- O₂ Linearity
- O₂ Manual Max (%)
- O₂ Auto Max (%)
- N₂ P Gain (%/DO%)
- N₂ I Time (min)
- N₂ D Time (min)
- N₂ Alpha
- N₂ Beta
- N₂ Gamma
- N₂ Linearity
- N₂ Manual Max (%)
- N₂ Auto Max (%)
- Deadband (DO%)

Pressure (page 204)

- Disconnected Pressure (V)
- Reusable Sensor (0 or 1)

Gas Data (page 205)

- N₂ Min (LPM)
- N₂ Off (V)
- O₂ Min (LPM)
- O₂ Off (V)
- PWM On Time (s)
- PWM Max Period (s)
- Mismatch Thresh (V)
- O₂ Min Volume (L)

Process Alarms (page 210)

- DO Low Low (%)
- DO Low (%)
- DO High (%)
- DO High High (%)

Interlocks

Conditions which interlock the main gas will also prevent N₂ and O₂ from flowing. For more information, see the “Interlocks” subsection of “Main Gas” on page 146.

pH

The pH PV is determined by a pH sensor. The software uses temperature compensation to provide more accurate pH readings. The software refers to it as “pH sensor A.”

The pH is controlled by varying the CO₂ flow in % composition of main gas flow and varying the percent of time the base pump is on. Increasing CO₂ flow decreases pH PV, and increasing base pump duty increases pH PV. To understand how the software determines which gases to flow, see “Main Gas” on page 145.

Before inoculating (i.e. when there is no metabolic activity), the pH has a predictable relationship with the concentration of sodium bicarbonate (NaHCO₃) in the medium and the % CO₂ composition. Below the following chart is the equation to calculate the resulting pH from a known concentration of sodium bicarbonate and a known % CO₂ composition. However, the following chart can be simpler to use.

To find the pH that would result from a known concentration of sodium bicarbonate and a known % CO₂ composition, draw a straight line between the points on the sodium bicarbonate and CO₂ axes. The line will cross the pH axis at the pH value. In fact, the chart can be used to find the third variable if any of the other two are known.

For example, if the medium being used has a sodium bicarbonate concentration of 3.7 g/L and the desired pH is 7.4, draw a straight line between those points on the corresponding axes, and extend the line to the CO₂ axis. You can see that a % CO₂ composition of just over 9% will result in the desired pH.

You can also see that to get the same pH using sodium bicarbonate concentrations of 2.2 g/L and 1.5 g/L will require % CO₂ compositions of about 5.5% and 3.5%, respectively.

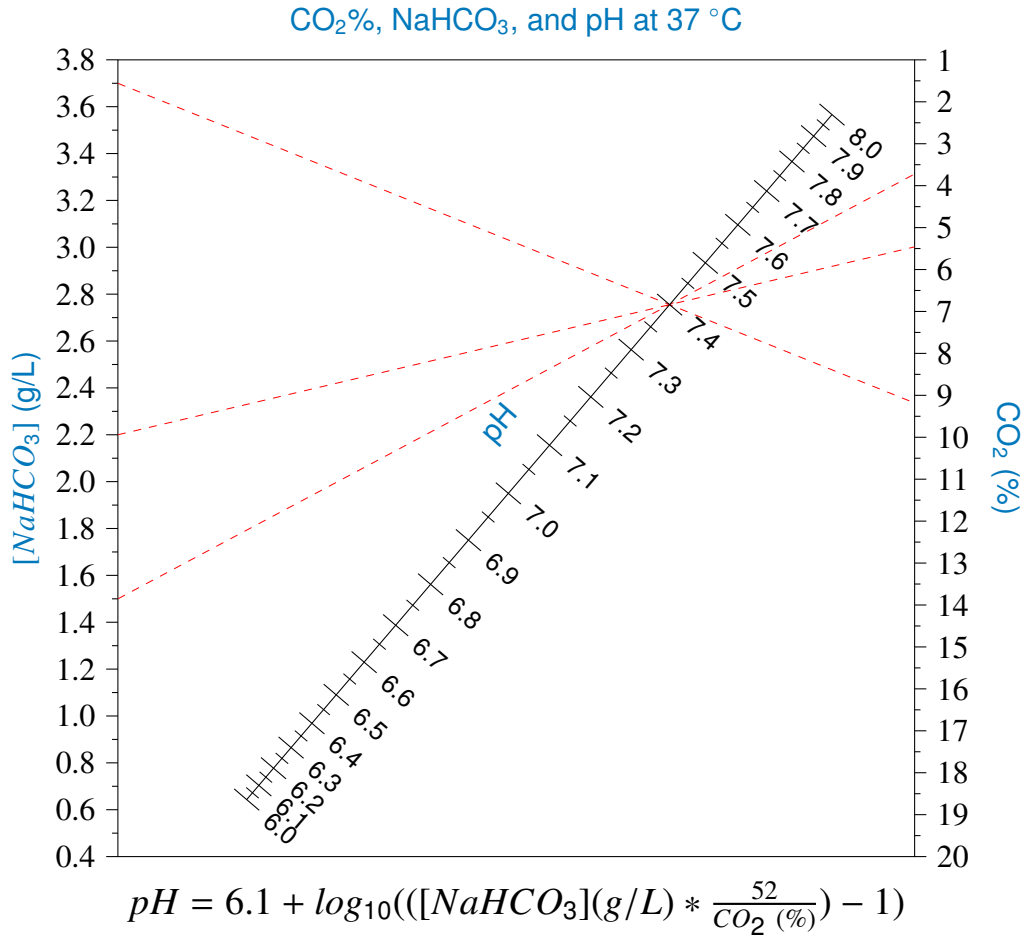

The pH controller has three user modes and one broken sensor mode:

- Off mode
- Manual mode
- Auto mode
- Broken sensor mode

Off Mode

CO₂ is 0% of main gas flow and base pump duty is 0%.

Manual Mode

User selects a CO₂ flow in % composition of main gas flow, and/or a base pump duty in % (the user must select the base pump as well).

Auto Mode

User selects a set point in pH units. If it will be necessary to use base, the user also selects a base pump. The software achieves the set point by adjusting CO₂ flow and base pump duty. Each has its own PID loop: while both the CO₂ loop and the base loop control to the pH set point, the CO₂ will only output if the pH PV is greater than the pH set point plus the pH “Deadband” setting, and the base will only output if the pH PV is less than the pH set point minus the pH “Deadband” setting.

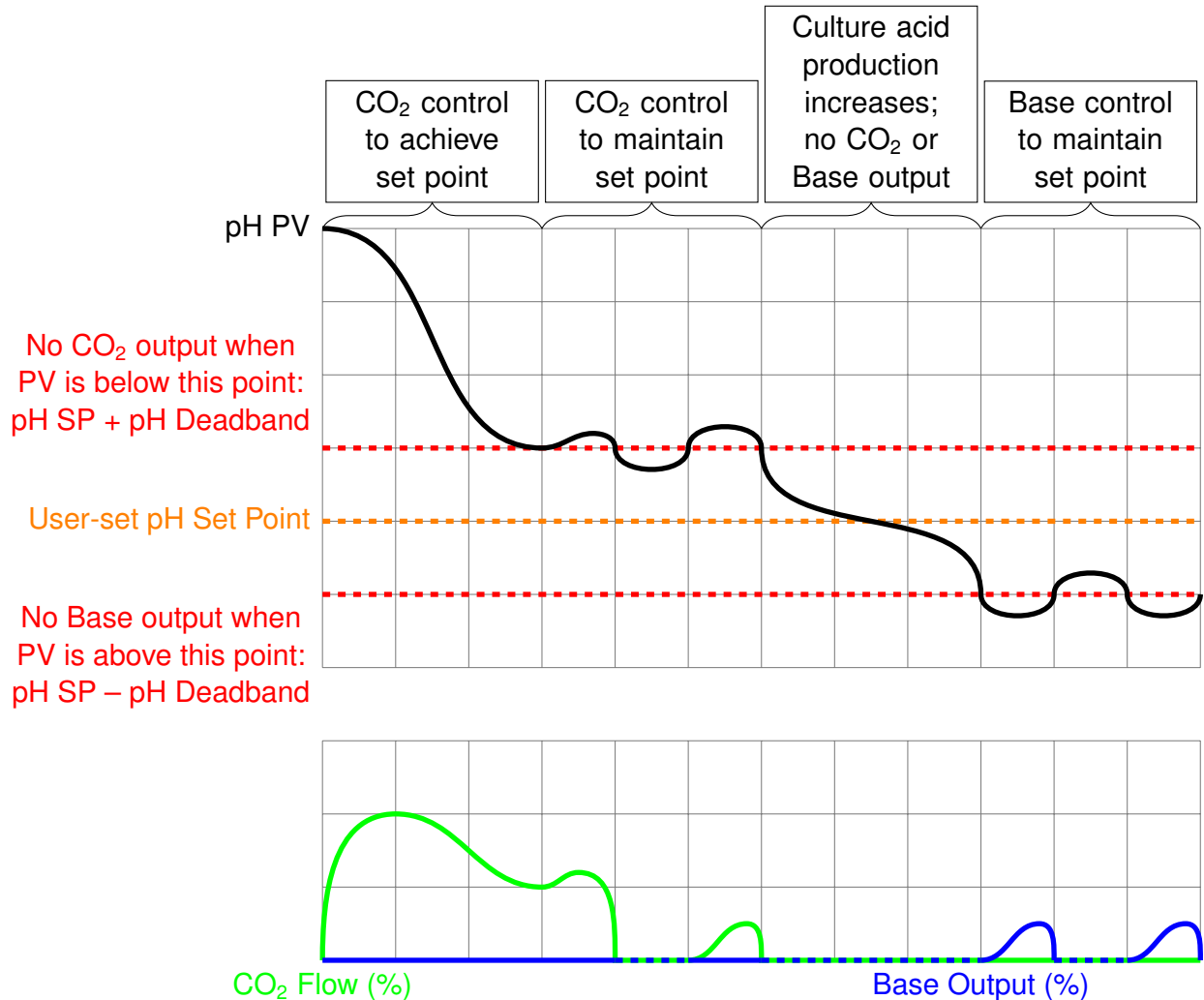

Broken Sensor Mode

When pH is in Auto mode and the pH sensor detects a PV outside the valid range, or the PV has changed by more than the “Rate Fail Delta PV” in the time “Rate Fail Delta Time (s),” the software assumes the sensor is broken, and outputs the average of its CO₂ and base pump output values during the last

100 seconds before the software entered broken sensor mode. Note that this is only intended to preserve short term stability – users should still take appropriate action in the event of sensor failure.

Output Ranges

The recommended CO₂ output is 0 - 100% CO₂ composition of main gas flow. The CO₂ MFC output is stated in “Gas Flow Rate Range” on page 52. CO₂ “pulsing” at the minimum value takes effect if the CO₂ % called for represents less than the MFC minimum flow rate.

The base pump output is technically 0 - 100% duty, however PBS Biotech Technical Support recommends using a range only up to your expected base consumption.

Relevant Settings

See Appendix 1 on page 188 for each setting’s default value, definition, and whether users can safely change the value without consulting PBS Biotech Technical Support.

pH (page 194)

- Rate Fail Delta PV
- Rate Fail Delta Time (s)
- CO₂ P Gain (%/pH)
- CO₂ I Time (min)
- CO₂ D Time (min)
- CO₂ Alpha
- CO₂ Beta
- CO₂ Gamma
- CO₂ Linearity
- CO₂ Manual Max (%)
- CO₂ Auto Max (%)
- Base P Gain (%/pH)
- Base I Time (min)
- Base D Time (min)
- Base Alpha
- Base Beta
- Base Gamma
- Base Linearity
- Base Manual Max (%)
- Base Auto Max (%)
- Base Wait Time (s)
- A Use Temp Comp?
- Deadband
- Valid High (pH)
- Valid Low (pH)

Pressure (page 204)

- Disconnected Pressure (V)
- Reusable Sensor (0 or 1)

Gas Data (page 205)

- CO₂ Min (LPM)
- CO₂ Off (V)
- PWM On Time (s)
- PWM Max Period (s)
- Mismatch Thresh (V)

Safety (page 208)

- Max Level (L)

Pumps (page 210)

- Base On Time (s)
- Base Max Period (s)

Process Alarms (page 210)

- pH Low Low
- pH Low
- pH High
- pH High High

Interlocks

Conditions which interlock the pumps will also prevent the Base Pump from turning on. See the “Interlocks” subsection of “Control Pumps” on page 158.

Conditions which interlock the Main Gas will also prevent CO₂ from flowing. See the “Interlocks” subsection of “Main Gas” on page 146.

Level Sensing

The PBS-15/80 has a built-in level sensor, which measures the difference in pressure between the top and bottom of the bag. Pressure at the top is measured through the pressure line, while pressure at the bottom is measured by a tubing line which slowly bubbles air into the bag. The software converts the net pressure to a height, and uses the geometry of the bag chamber to convert the height to a volume.

For the level sensor to work properly, the user must perform a ‘zero’ calibration at 0 L with an empty bag. After filling the bag with medium, before turning any controls on, the user should perform a ‘span’ calibration if the Level reading reported by the software is significantly different from the actual volume in the bag.

The working level range of the PBS-15 is 9 – 15 L, and for the PBS-80 it is 50 – 80 L. Below the minimum, the Vertical-Wheel® impeller is not fully covered and may not function optimally, but certain processing steps may be performed with volumes as low as 3 L for the PBS-15 and 16 L for the PBS-80. Above the maximum there is the danger of overfilling the bag, causing overflow.

Disconnecting the Level Sensing Line

This expands on the “Level sensing line” warning on page 21. The level sensing line cannot be allowed to fill with liquid, and the level sensing line

cannot be connected to the PBS-15/80 while gas flows through the Micro-gas line and the line is clamped.

When the bag is filled with liquid, and the level sensing line is not clamped and is then disconnected from the PBS-15/80, liquid will fill the level sensing line up to the check valve. When the level sensing line is then reconnected to the PBS-15/80, a small amount of air will again flow into the level sensing line.

Because there is now liquid on the 'bag' side of the check valve instead of air, more pressure is required to open the check valve, and the calculated level is then less accurate. Additionally, because there is only a small amount of air flowing in to the level sensing line, a critical mass of liquid flows back through the check valve, eventually wetting and clogging the filter in the line. The amount of air flow is too small to ever displace the liquid that settles in the line.

The other important consideration is the level sensor itself. If the line is clamped, and the level sensing connector and the Micro-gas connector are both connected to the PBS-15/80, and gas flows into the Micro-gas line, there is a risk of exposing the level sensor to a pressure high enough to damage it. The check valve in the level sensing line should not be relied on to prevent the level sensor from being exposed to this high pressure from gas flowing from the Micro-gas line.

To disconnect the level sensing line:

1. Prevent gas from flowing out of the Micro-gas connector on the PBS-15/80. The simplest way is to turn DO Off.
2. Clamp the level sensing line as close to the bag as possible.
3. Disconnect the level sensing line and Micro-gas line.

To reconnect the level sensing line:

1. Prevent gas from flowing out of the Micro-gas connector on the PBS-15/80.
2. Reconnect the level sensing line and Micro-gas line.
3. Wait 1 – 2 minutes.
4. Open the clamp on the level sensing line.
5. Allow gas to flow out of the Micro-gas connector on the PBS-15/80.

Waiting between reconnecting the level sensing line and opening the clamp allows air pressure to build up in the line. When the clamp is opened, the pressurized air then prevents liquid from entering the line.

Relevant Settings

See Appendix 1 on page 188 for each setting's default value, definition, and whether users can safely change the value without consulting PBS Biotech Technical Support.

Level (page 203)

- Radius (cm)
- Empty Level (V)
- Empty Level (L)
- cm/psi
- Vessel Depth (cm)
- Bottom Gap (cm)
- Enable Sensor (0 or 1)
- CalLevelSlopeMax(psi/V)
- CalLevelSlopeMin(psi/V)
- CalLevelInterceptMax(psi)
- CalLevelInterceptMin(psi)

Safety (page 208)

- Min Level (L)
- Max Level (L)

Process Alarms (page 210)

- Level Low Low (L)
- Level Low (L)
- Level High (L)
- Level High High (L)

Filter Oven

The filter oven keeps the exhaust filter at an elevated temperature to reduce moisture accumulation in the exhaust filter. The factory default is 38 °C.

The filter oven's temperature PV is determined by a temperature sensor positioned inside the filter oven.

NOTICE The filter oven should only be set to Off mode when the PBS-15/80 is not in use. Otherwise it should be in Auto mode.

Off Mode

The filter oven heater is off.

Manual Mode

User selects a filter oven heater duty as a percentage of its maximum power.

Auto Mode

User selects a set point in °C. A PID controller varies the filter oven heater duty to attempt to achieve the set point.

Broken Sensor Mode

When filter oven is in Auto mode and the filter oven temperature sensor detects a PV outside the valid temperature range, the software assumes the sensor is broken, and outputs the average of its output values during the last 100 seconds before the software entered broken sensor mode. Note that this is only intended to preserve short term stability – users should still take appropriate action in the event of sensor failure.

Output Ranges

The filter oven heater duty range is 0 - 100%.

Relevant Settings

See Appendix 1 on page 188 for each setting's default value, definition, and whether users can safely change the value without consulting PBS Biotech Technical Support.

Temperature (page 188)

- Valid High (C)
- Valid Low (C)

Filter Oven (page 190)

- P Gain (%/C)
- I Time (min)
- D Time (min)
- Alpha
- Beta
- Gamma
- Linearity
- Heat Manual Max (%)
- Heat Auto Max (%)

Process Alarms (page 210)

- Filter Oven Low Low (C)
- Filter Oven Low (C)
- Filter Oven High (C)
- Filter Oven High High (C)

Interlocks

The PBS-15/80 has no interlocks that prevent the filter oven heater from turning on.

Pressure Sensing

The PBS-15/80 has a built-in pressure sensor which monitors the pressure in the line between the bag and condenser bag. The pressure detected is displayed as the pressure PV in the software.

Relevant Settings

See Appendix 1 on page 188 for each setting's default value, definition, and whether users can safely change the value without consulting PBS Biotech Technical Support.

Pressure (page 204)

- Disconnected Pressure (V)
- CalPressureInterceptMax (psi)
- CalPressureInterceptMin (psi)
- CalPressureSlopeMax (psi/V)
- CalPressureSlopeMin (psi/V)
- Reusable Sensor (0 or 1)

Safety (page 208)

- Max Pressure (psi)
- Max Pressure Door (psi)

Process Alarms (page 210)

- Pressure Low Low (psi)
- Pressure Low (psi)
- Pressure High (psi)
- Pressure High High (psi)

Leak Sensing

The PBS-15/80 comes with a sensor to detect if a bag leaks based on the presence of liquid. It will stop reporting a leak once its contacts are dry.

Control Pumps

Types (Media and Additions A and B)

The media pump is meant for large scale additions of medium before or during a run.

The additions pumps are meant to be used throughout the run, for slow, medium, or fast titrations or quick one-time additions. Their pump speeds are adjustable. It is also an addition pump that the user must choose as the base pump if they desire base control – neither addition pump is automatically selected.

Relevant Settings

See Appendix 1 on page 188 for each setting's default value, definition, and whether users can safely change the value without consulting PBS Biotech Technical Support.

Level (page 203)

- Enable Sensor (0 or 1)

Pressure (page 204)

- Disconnected Pressure (V)
- Reusable Sensor (0 or 1)

Safety (page 208)

- Max Pressure (psi)
- Max Level (L)

Pumps (page 210)

- Aux Low Duty
- Aux Med Duty
- Base On Time (s)
- Base Max Period

Interlocks

The media and addition pumps will not turn on if the pressure PV is greater than the Safety “Max Pressure (psi)” setting, the software detects the pressure sensing line is disconnected, or the level PV is greater than the “Max Level (L).” This prevents medium or additions being added to the point of overfilling the bag or causing it to become over pressurized.

Main Light

The PBS-15/80 has a white LED light to illuminate the contents of the bag. It can be turned on and off through the software.

Door

The door on the PBS-15/80 only unlocks when it would be safe for the user to open it. There is no need for a user to open the door, other than to install an empty bag or to remove an empty bag.

Relevant Settings

See Appendix 1 on page 188 for each setting’s default value, definition, and whether users can safely change the value without consulting PBS Biotech Technical Support.

Level (page 203)

- Enable Sensor (0 or 1)

Pressure (page 204)

- Disconnected Pressure (V)
- Reusable Sensor (0 or 1)

Safety (page 208)

- Max Pressure Door (psi)

Interlocks

The door will not unlock if the pressure PV is above the Safety “Max Pressure Door (psi)” setting.

The door will not unlock if the software recognizes that the pressure sensing line is disconnected.

The door will not unlock if the level PV is greater than 0.00 L.

The door will not unlock if the agitation PV is greater than 0 RPM.

Calibrating/Configuring Sensors

Pre-Calibration Medium Conditioning Strategy

After adding cell culture medium but before inoculating with cells, the DO and pH sensors must be calibrated. This is because autoclaving the sensors affects their calibration. Before the DO and pH sensors are calibrated, their reported measurements should not be considered accurate or reliable. In order to calibrate these sensors, the cell culture medium first needs to be conditioned, and the reported sensor PVs need to equilibrate. The controls should be set so the medium is in the ideal condition for the cells being cultured.

One reason for this is that if the medium is already in the ideal condition for the cells being cultured, the operators will not have to wait any time between calibrating the DO and pH sensors and inoculating with the cells. For example, if the operator were to set pH in Auto mode before calibrating, with a set point of pH=7.4, the software will adjust the percent of CO₂ in the headspace until the pH sensor reports a measurement of 7.4. However, because the sensor has not been calibrated yet, and autoclaving affects sensor response (which is why calibrating them is necessary), the actual pH of the media in the bag is very unlikely to be 7.4. If it is actually 7.5 or 7.3, for example, then after performing a calibration, the operator will have to wait to inoculate until the software adjusts the percent of CO₂ in the headspace and the pH sensor again reports a measurement of 7.4. Otherwise the bioreactor wouldn't be an optimal environment for the cells. But if the operator knew that the cell culture medium will have a pH of 7.4 from running 5% CO₂ in the headspace, the operator could set pH to Manual mode at 5% CO₂ to equilibrate (see the “NaHCO₃, CO₂%, and pH at 37 °C” chart on page 149 for more information). After equilibration and before calibration, it would not matter if the pH sensor reports

7.3 or 7.5, because the operator would calibrate it to be 7.4 (after verifying by taking a sample and measuring its pH). The operator could then immediately inoculate because the bioreactor would already be an optimal environment for the cells.

A second reason is that the DO and pH sensors should be calibrated to a measurement that is as close as possible to the condition the software will be controlling to during the cell culture run. This will minimize inaccuracy in the reported sensor measurement. Calibrating to a measurement which will not actually be controlled to introduces unnecessary inaccuracy in the reported sensor measurement. While the software uses a straight line $y = mx + b$ as the relationship between the sensor's raw output and the calculated PV, no sensor is 100% perfect, and there are inaccuracies. In the above example, when the operator put pH in Auto mode with a set point of 7.4 before calibrating, let's say that the actual PV was 7.3. When the operator then calibrates the pH to read 7.3, the sensor's reading at that single point has less inaccuracy than it would for any other pH PV. But because the operator intends to control the pH at 7.4 during the cell culture run via Auto mode, it would be in their best interest to manually control pH to conditions that will result in the pH being 7.4 before that first calibration. This can be accomplished by using the "NaHCO₃, CO₂%, and pH at 37 °C" chart on page 149 and setting the CO₂% by putting pH in Manual mode. Then, the operator could calibrate the pH reading to equal 7.4, and the running condition will match the PV where sensor inaccuracy has been minimized.

The agitation and main gas controls need to be on, so the contents of the bag are mixed homogeneously, the Temperature is not interlocked, and the gases flowing through the headspace are able to efficiently diffuse into the medium. The agitation can be set to control to a higher RPM during this stage than when the bioreactor is inoculated, to speed up the process of conditioning the medium. Similarly, setting main gas flow to a higher flow rate during this stage than when the bioreactor is inoculated will also speed up the process of conditioning the medium. Or, operators could instead choose to set the main gas flow to a lower flow rate, to minimize gas use before inoculation. This may require additional time to condition the medium. The temperature control should be set to the temperature optimal for the cells. For most applications, this is 37 °C. This is important because the temperature of the medium has an effect on both the DO and pH of the medium.

It is recommended to condition the medium before these first calibrations by controlling DO and pH in Manual mode, rather than Auto mode. As explained above, this saves time and also minimizes calibration inaccuracy. Additionally, if DO is controlled in Auto mode, then the operator would be required to measure the DO of a sample to use as a reference when performing the

calibration. For both pH and DO, regardless of whether the controller is in Auto or Manual mode, care must be taken when taking the sample and measuring it to ensure accuracy, as off-gassing can result in the sample's gas composition changing to be different from that of the medium. This is especially difficult to avoid for the DO. For more information, see "Take Sample" on page 171. This off-gassing can lead to the measurement of the sample not being accurate, and calibrations being performed to inaccurate or non-representative reference measurements can result in the calibrated sensor measurements being less accurate.

While it is technically possible to use DO and/or pH in Auto mode when conditioning the medium before performing the 'span'/'one-point' calibrations, it is not recommended for the reasons explained above. Before inoculation, the gas composition of the headspace has a reliable and predictable effect on the gas composition of the medium. This means that putting DO and pH in Manual mode allows the operator to directly control the actual DO and pH of the medium. This allows the operator to use a very reliable and accurate reference when performing the 'span'/'one-point' calibrations after the medium is conditioned and the sensor readings equilibrate.

Selecting Sensors

Sensors fail by registering PVs outside a valid range. Additionally, pH sensors can fail by registering a rapid PV change. When a sensor is failed, it is considered "inactive" by the software, and appears in red in the Select Sensors menu. If the control is in Auto mode but there is no "active" sensor, the control will enter broken sensor mode.

If a sensor type has no duplicate sensor, when that sensor stops failing (it is back in valid range, or for pH its PV stabilizes), it is "active" again.

For duplicate sensors, a sensor which stops failing will remain "inactive" until the user reactivates it, or its sibling sensor fails. The software will use the PV of the user-preferred sensor if it is "active" or if both sensors are failing. Otherwise it will use the PV of the other sensor. Users can perform the following actions in the Select Sensors menu, which can affect which sensor PV the software will use:

- Tell the software which sensor they prefer (clicking the slider).
- Reactivate a sensor that has gone out of range and come back into range, and which the user knows is trustworthy (clicking the Do Not Enter symbol DNE - ☹).
- Lock out a sensor that is not in use or is not trustworthy (closing the lock).
- Choose to use a previously locked-out sensor (opening the lock).

Which Sensors Can Be Calibrated

It is possible to perform calibrations on the following sensors. Their calibration slope and intercept (m and b) values can also be manually entered; however, this should not be done without consulting PBS Biotech Technical Support.

Dissolved Oxygen

For a reusable DO sensor, the user should perform a 'two-point' calibration before autoclaving it, and an additional 'one-point'/'span' calibration before inoculation. It is generally not recommended that users perform additional 'one-point'/'span' calibrations during a run. Users should not perform additional 'two-point' calibrations during a run, or manually enter calibration slope and intercept (m and b) values, without consulting PBS Biotech Technical Support.

This is because before inoculating with cells, the gas composition of the headspace has a reliable and predictable effect on the actual DO of the medium, so the operator can directly control the DO by putting pH and DO in Manual mode. This is the best reference to use when calibrating the DO sensor.

After inoculating with cells, the cells' oxygen consumption additionally affects the actual DO of the medium, and so it can no longer be determined only based on the gas composition of the headspace. This means that a reference sample will have to be taken and measured, and the DO would have to be calibrated to that reference measurement. Taking the sample and handling it afterwards can introduce additional air to the sample and result in off-gassing, so the sample's gas composition no longer matches that of the media in the bag, and the measured DO of the sample is not representative of the DO of the media in the bag. For more information, see "Sampling for DO Measurement" on page 173. Calibrating to an inaccurate or non-representative reference measurement can result in the calibrated sensor measurements being less accurate.

Additionally, for most applications, the DO sensor drift is minimal throughout a cell culture run. If sensor drift is suspected to be an issue for a process, it needs to be confirmed by isolating as many variables as possible when taking reference samples. Contact Applications Engineering at app.eng@pbsbiotech.com for additional information. If sensor drift is confirmed to be an issue for a process, the methods of collecting a sample and measuring it need to be confirmed to change the DO of the sample as little as possible for the reference measurement to be reliable. For more information, see "Sampling for DO Measurement" on page 173.

pH

For a reusable pH sensor, the user should perform a 'two-point' calibration before autoclaving it. Users should perform 'one-point' calibrations throughout a run if the measured pH of a sample shows that the sensor has drifted. Users should not perform additional 'two-point' calibrations during a run, or manually enter calibration slope and intercept (m and b) values without consulting PBS Biotech Technical Support.

Level

Users should perform a 'zero' calibration on an empty bag at the beginning of a run. After filling the bag with medium, before turning any controls on, the user should perform a 'span' calibration if the Level reading reported by the software is significantly different from the actual volume in the bag. Level calibrations cannot be performed from the Hello UI while the agitation, main gas, or dissolved oxygen controls are on.

Temperature

The PBS-15/80 is shipped with its temperature sensors already calibrated. Users should not calibrate the temperature sensor without consulting PBS Biotech Technical Support.

Filter Oven Temperature

The PBS-15/80 is shipped with its filter oven temperature sensor already calibrated. Users should not calibrate the filter oven temperature sensor without consulting PBS Biotech Technical Support.

Pressure

Users should perform a 'zero' calibration on the pressure sensor before starting a run. No other calibrations should be performed on this sensor without consulting PBS Biotech Technical Support.

Temperature Compensation

The temperature of the pH sensor has a predictable effect on the sensor's response. If the temperature PV differs from the temperature of the pH sensor when it was calibrated, the software is able to compensate for this, using the Nernst equation.

Calibration Types

The PBS software supports multiple calibration types for each sensor. However, not all calibration types are appropriate for all sensors or all situations.

All the calibrations rely on there being a linear relationship between the sensor's raw voltage signal and the reported Present Value. This means the calibration curves take the form of

$$y = mx + b$$

where y is the final calculated Present Value (PV) (% for DO, L for Level, etc.), m is the calibration slope, x is the sensor's raw voltage signal, and b is the intercept. All calibration operations involve changing the slope and/or intercept so when the sensor reports a particular raw voltage value, the calculated Present Value is different than it would have been when the original calibration values were in use.

In all the examples below, the calibration slope and intercept values do not correspond to the expected calibration values for any actual sensors on the PBS-15/80.

Zero

A 'zero' calibration involves keeping the original calibration's slope, and adjusting the intercept so the PV equals zero at the calibration condition. This requires being able to reliably create conditions where the PV for that sensor type should equal 0.

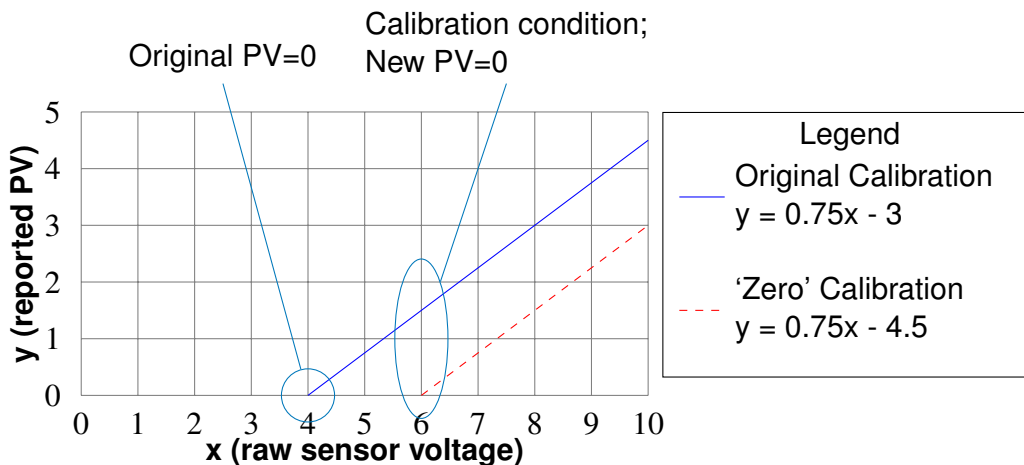

In the above example, the calibration would have been performed when the raw sensor voltage was 6. With the original calibration values, the PV would have been 1.5, but the operator knew that the actual PV should be 0 under that condition. The slope stayed at 0.75, but the intercept changed from -3 to -4.5.

This calibration type is applicable to sensors whose PV=0 condition is relevant and easily and reliably achieved:

- When an empty bag is installed, the Level PV should be 0.
- For the pressure sensor, PV=0 is achieved when the bag is not under any pressure and no gas is flowing.

Two-point

A 'two-point' calibration involves quickly changing between two created calibration conditions, where the operator reliably knows what the PV should be at each condition. Usually, both the slope and intercept change as a result of performing a 'two-point' calibration.

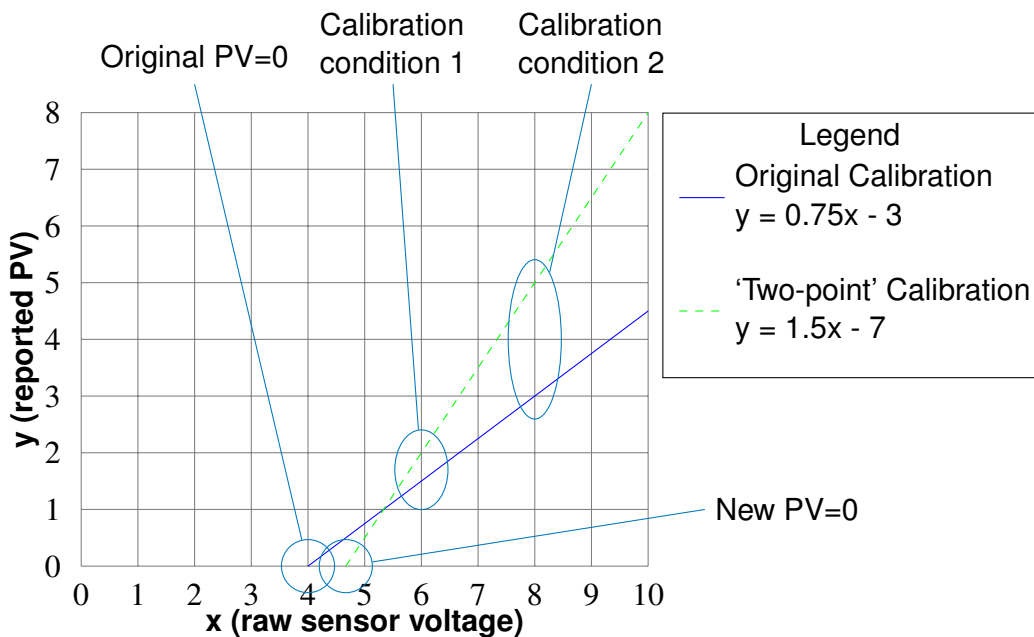

In the above example, the calibration would have been performed when the raw sensor voltage was 6 for the first point and 8 for the second point. With the original calibration values, the PV would have been 1.5 at the first point and 3 at the second point, but the operator knew that the actual PVs should be 2 under the first condition, and 5 under the second condition. This calibration type resulted in the slope, intercept, and PV=0 all changing.

This calibration type is applicable to sensors for which 2 conditions can be quickly and reliably created:

- For the pH sensor, this calibration is performed by using 2 different calibration buffer solutions, before autoclaving the sensor.
- For the DO sensor, this calibration is performed by keeping the DO sensor connected and exposed to a known gas composition for one of the points, and disconnecting the DO sensor to mimic the PV=0 condition for the other point.

Span and Offset

Both 'span' and 'offset' calibrations take a single new PV from the operator under a specific condition. A 'span' calibration preserves the PV=0 condition from the original calibration by changing the slope and intercept, whereas an 'offset' calibration preserves the slope from the original calibration, and the intercept and PV=0 condition change. The software refers to 'offset' calibrations as 'one-point' calibrations, except what the software refers to as a 'one-point' DO calibration is actually a 'span' calibration.

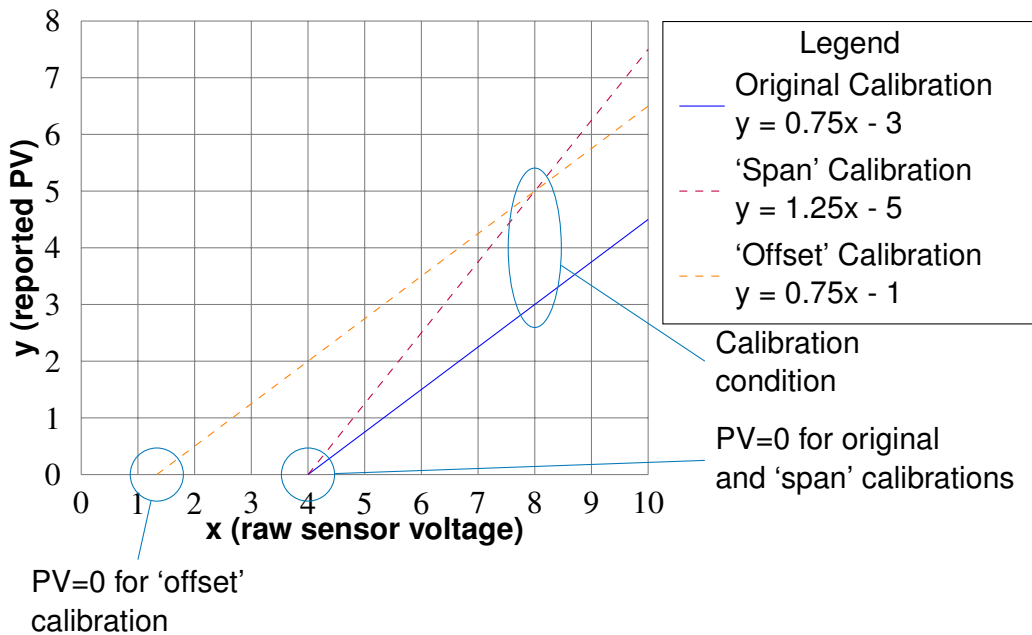

In the above example, the calibration would have been performed when the raw sensor voltage was 8. With the original calibration values, the PV would have been 3, but the operator knew that the actual PV should be 5 under that condition. If the operator had chosen to perform a 'span' calibration, the PV=0 condition would have been preserved, and the slope and intercept would have changed. If the operator instead had chosen to perform an 'offset'/'one-point' calibration, the original slope of 0.75 would have been preserved, and the intercept and PV=0 condition would have changed.

Whether it is more important to preserve the original calibration's slope by performing an 'offset'/'one-point' calibration, or it is more important to preserve the original calibration's PV=0 condition by performing a 'span' calibration, depends on the sensor, and how relevant the PV=0 condition is:

- For the pH sensor, pH=0 is not a relevant condition, and therefore 'offset'/'one-point' calibrations, and not 'span' calibrations, should be performed.
- For the DO sensor, DO=0% is a relevant condition, and therefore 'span' calibrations, and not 'offset'/'one-point' calibrations, should be performed. While the button is labeled "One-point," the software performs a 'span' calibration.
- For the Level sensor, Level=0 L is a relevant condition, and should have been set by performing a 'zero' calibration on the empty bag. Therefore after filling a bag, a 'span' calibration is appropriate to perform.

Manual

Calibration slope and intercept values can also be manually entered; however, this should not be done without consulting PBS Biotech Technical Support.

Recipes

Recipes are configured in the Desktop UI and run in the Hello UI. The engine uses a simple interpreter which reads and writes directly to the bioreactor's internal state.

Actions and Looping

“Set” – Select this action when you want to set a variable to a specific value. For example, selecting the variable “AgModeUser (Agitation)” and then selecting the “Auto” button would result in the recipe changing the agitation mode to “Auto.”

“Wait” – Select this action when you want the recipe to wait for a specified period of time before moving on to the next step. For example, selecting

this action and then entering “10” in the ‘ValNum’ field would result in the recipe waiting for 10 seconds before moving on to the next step.

“Wait Until” – Select this action when you want a variable to reach a specific value or state before the recipe moves on to the next step. For example, selecting the variable “AgPV(RPM) (Agitation),” selecting “>= (greater than or equal to)” in the ‘Compare’ field, and then entering “10” in the ‘ValNum’ field would result in the recipe waiting until the agitation present value equaled 10 RPM before moving on to the next step.

“Loop” – Select this action when you want the entire recipe to loop until the user stops the recipe. To configure a recipe to loop, select the recipe in the ‘Recipe List’ field and click the “Loop” button. The recipe name will now have “–LoopRecipe” after it. To set a looping recipe to not loop, select the looping recipe and click the “Don’t Loop” button.

Which Variable Types Recipes Can Change

For a complete list of variables the software uses, see Appendix 4 on page 224.

User Source

All variables which are “User” Source can be changed using a recipe. This includes variables such as modes, set points, and pump speeds. Changing these variables with a recipe works the same as changing them through the Hello UI or the Desktop UI.

System Source

All variables which are “System” Source can be changed using a recipe. Changing calibration slopes and intercepts with a recipe is the same as changing them by performing a calibration, and changing “System” Source variables with a corresponding System Variable are the same as changing a setting in the Hello UI’s Settings tab or in the Settings editor of the Desktop UI. However, changing other “System” Source variables via recipe should be treated as temporary; if the RIO is rebooted or loses power, the changes will be reverted when it is booted up again.

Sensor and Calculated Sources

All other variables can also be changed using a recipe, but may be immediately overridden by the software. These variables include calculated values such as PVs and raw sensor values.

Other Information About Recipes

Recipes can only be run one at a time, and cannot refer to other recipes.

Ending a recipe prematurely causes the recipe to end at the current step, and does not reset anything. Consider the following recipe:

1. Set “Pumps&ValvesPumpUser1” to Low
2. Wait 60 seconds
3. Set “Pumps&ValvesPumpUser1” to Off

If the above recipe were stopped after only 30 seconds, the pump would continue to run, until a user stopped the pump themselves in the “Control Pumps” menu. Similarly, after a user starts that recipe, the pump can still be stopped in the “Control Pumps” menu.

Use caution with “Wait Until” steps involving PV, particularly when using the “equal to” comparison, as present values are often calculated as being very slightly above or below the set point. For example, a recipe with a step reading ‘Wait Until “TempPV(C)” = 37’ could stall on that step indefinitely if the temperature PV is 37.001. The step would be better written as ‘Wait until TempPV(C)” >= 37’ to avoid this problem.

Users should also remain conscious of any user-selectable parameters that may interfere with a recipe step.

Reports

Reports contain data from a specified time span or from an individual batch. They are generated as .csv files with their creation time as their name. If generated through the Hello UI, these reports are automatically emailed to the user who generated them, if the user has a registered email address. If generated through the Hello UI on a remote computer, these reports can be downloaded using the generated link. All reports that are generated can be copied onto an external drive using the File Browser menu in the Desktop UI.

Types

Process Data – Contain process data logged for variables specified in the Logger Settings.log file. See below for more information.

User Events – Contains all actions a user takes, with the following exceptions: screen navigation, saving an Alarm file without making it active, saving a Logger file without making it active, saving a System Variables file that is not named System Variables.sys without making it active. When a config file is made active, a user event is generated and includes the contents of the file.

Errors – Contains information used for debugging, and is not necessary for users under ordinary circumstances.

Alarms – Contains information about alarms that are generated, when they are acknowledged, and which user acknowledged them.

Recipe Steps – Contains all recipe steps executed by the software, and at what time they were started.

Process Data Recording

The Logger Settings.log file determines which variables' process data will be recorded. In addition to selecting what data to record, each variable has a “deadband” that says its value will be recorded if it changes by the deadband amount. The System “Max Data Log Interval (min)” setting determines how frequently the data will be recorded if it is changing less than the deadband.

For example, if the agitation PV is set to be recorded with a deadband of 1 RPM, and the “Max Data Log Interval” is 15 seconds, the following chart shows when the PV will be recorded:

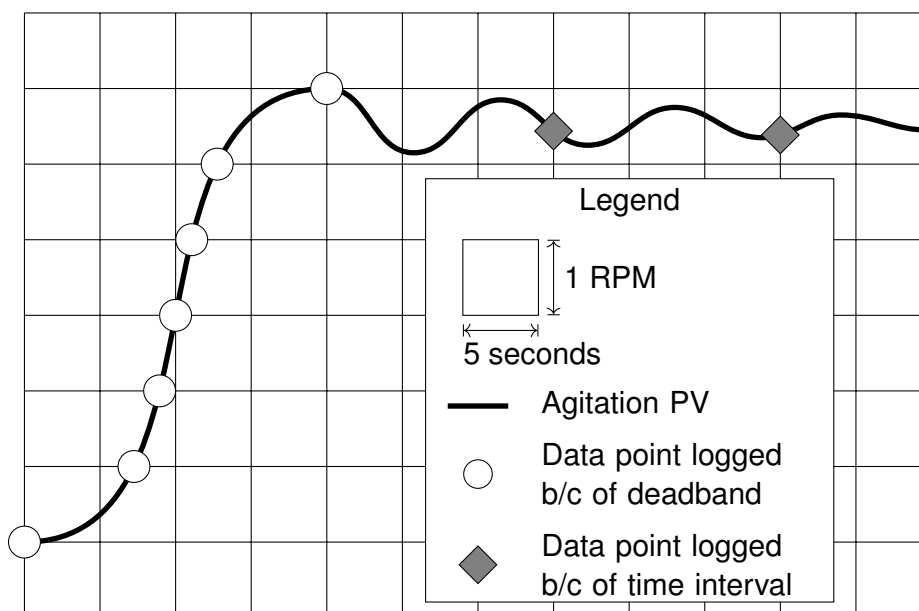

The combination of time-dependent data recording and change-related data recording can be used to ensure that useful data is recorded without flooding the database.

For definitions of all logger variables and default deadbands, see Appendix 4 on page 224.

Database

The active database is called PBSBioreactorDatabase.mdb and contains all data recorded by the system. Its contents are compatible with any application that can read MDB format.

The database will be automatically archived by the PBS Software when it reaches a certain size. It can also be manually archived by users (see “Manually Archiving DBs” on page 124). When the database is archived, a new .mdb file named “Archive000.mdb” will appear, where “000” is the next sequential number of archived databases that have been created. The Database History File.csv contains records of all the archived databases. The included information is: the database name, the Start Time, the End Time, the MD5 Checksum, the Time Deleted (if applicable), and the User who deleted the archived database (if applicable).

The MD5 Checksum is a unique text string generated at the time the database was archived. To confirm that a copy of a database has not been compromised, third-party software can be used to determine the MD5 Checksum of the copy, and compare the result to the MD5 Checksum of the original listed in the database history file (refer to your IT department for further assistance). The Database History File can be viewed in the Desktop UI’s “About” tab, or it can be copied from the Database folder to an external drive.

Take Sample

For instructions to take a sample manually, see “Take Sample” on page 116.

The sequence illustrated in the Hello UI’s “Take Sample” menu is not applicable to the PBS-15/80. This is because the bag does not come with a syringe, and because gravity causes liquid to flow into the sample line on the PBS-15/80, so the pump is not necessary for all steps.

Do not attempt to combine samples for different types of analyses, for example measuring the pH of a sample that is going to be processed for cell counts. This will introduce more variability and error into the cell count. Each sample should be unique.

When validating any sampling and measurement method, multiple samples should be taken and compared to understand the inherent variation.

Sampling for Cell Counting

Sample should be representative of the culture – A representative sample should have the same proportion of healthy cells as in the bag. If the

cells are growing in aggregates or microcarrier clumps, those amounts and morphologies should be reflected in the sample as well.

Volume – A sample of 10 mL or larger is recommended for cell counts.

Sample Method – Factors which impact how representative a sample is are the shear force the sample is subjected to as it is taken, the speed at which the sample is taken, and the location in the bag from which the sample is taken. Passing a sample through a pump or small connectors can subject the sample to shear force and affect cell health/viability, and affect the size/shape of aggregates or microcarrier clumps. Sampling speed and location can impact the number of total cells contained in a sample.

Handling Sample – For viability counts, the sample should be handled and processed as quickly and gently as possible to avoid artificially increasing the percent of dead or unhealthy cells.

Counting Cells in Sample – Users should validate their cell count method by taking multiple samples and comparing them, to understand the inherent variation.

Sampling for pH Measurement

Concerns – As a sample is removed and manipulated, CO₂ in the cell culture medium can be stripped out and replaced with air, which will increase the pH. A sample which is left to sit in ambient conditions will also experience off-gassing, which will have the same effect as actively stripping out the CO₂. The reverse can also happen; cellular metabolic activity may continue in the sample, causing the CO₂ and/or lactic acid to be higher than the concentration in the bag.

Volume – A sample of sufficient size for the offline pH meter to read it should be taken.

Sample Method – Minimize turbulence and air exposure while taking the sample. The bioreactor tubing is gas permeable, so as soon as liquid leaves the bag environment it is changing from its in situ conditions.

Handling Sample – Minimize turbulence and air exposure while handling the sample - perform the measurement as quickly as possible.

Measuring Sample – Getting a measurement as quickly as possible should be the priority. A dedicated benchtop pH meter will give a measurement more quickly than a metabolite analyzer, for example. The sampling and pH measurement methods can also be validated. Before inoculating with cells, when the % CO₂ composition is manually set and the pH PV has stabilized, the measured pH should match the expected pH from the “NaHCO₃, CO₂%, and pH at 37 °C” chart on page 149, given the % CO₂

composition and sodium bicarbonate concentration of the medium. Taking a sample can introduce air and strip out CO₂, causing the sample's measured pH to be higher than that in the actual bioreactor. Comparing the sample's measured pH to the theoretical pH based on the % CO₂ composition and sodium bicarbonate concentration of the medium is a good way to verify that the samples are being taken and handled appropriately.

Sampling for DO Measurement

Sampling for measuring the DO can be done regularly, but DO calibration should only be performed if DO sensor drift has been confirmed to be a significant issue. It's possible to introduce significant error by measuring the DO of a sample, and this concern should be weighed against concerns about sensor drift.

Concerns – As a sample is removed and manipulated, it will be rapidly equilibrating to the gas composition of atmospheric air, which will result in the DO of the sample rapidly approaching 100%. A sample which is left to sit in ambient conditions will also experience off-gassing, which will have the same effects as actively stripping out the other gases. Cellular metabolic activity might also continue in the sample, causing the O₂ to be lower than that of the media in the bag.

Volume – A sample of sufficient size for the offline gas analyzer to read it should be taken.

Sample Method – Minimize turbulence and air exposure while taking the sample. The bioreactor tubing is gas permeable, so as soon as liquid leaves the bag environment it is changing from its in situ conditions.

Handling Sample – Minimize turbulence and air exposure while handling the sample - perform the measurement as quickly as possible.

Measuring Sample – Getting a measurement as quickly as possible should be the priority. A blood gas analyzer will give a measurement more quickly than a metabolite analyzer, for example. The sampling and DO measurement methods can also be validated. Before inoculating with cells, when the % composition of the CO₂ and N₂ in the headspace is manually set and the DO PV has stabilized, the measured DO should match the percent of air entering the headspace. Comparing the sample's measured DO to the theoretical DO is a good way to verify that the samples are being taken and handled appropriately.

Load Bag

The Load Bag feature allows the database to store the bag expiration date, part number, and serial number used for particular batches.

Batch

Rather than manually recording the start and end dates of various runs, users can start a new batch when they start a new run and end it after harvest. This makes it easier to access the relevant data for generating a report.

Advanced View

The “Advanced” menu allows the user to see more detailed information than is displayed in the Dashboard.

Windows/HMI Log Off

Users can log out of the HMI computer from the Desktop UI. This feature is used when a customer’s IT department requires access to their Admin account on the Windows/HMI computer. Internal protocols must be followed to ensure that nobody with access to the Windows Admin account modifies or deletes any data.

Restart

Users can restart the HMI computer from the Hello UI or from the Desktop UI. Because of the unique architecture combining the RIO controller and HMI, the user is able to reboot the HMI without interrupting run control. If the HMI stops responding or a software update requires a restart, the user can reboot the HMI without losing crucial functionality. For instructions to restart the HMI, see “Restarting the HMI Computer” on page 78.

Alarms

The Alarms configuration file (Alarms.alm) is configured in the Desktop UI. Alarm monitoring is handled by the RIO, while user alerts are displayed in the Hello UI, and emails about alarms are sent by the HMI computer.

There are two types of alarms on the PBS-15/80:

Process Alarms – Triggered when the PV deviates outside the user-defined High and Low range, or High High and Low Low range, for each variable. These ranges are defined in the Process Alarms submenu of the “Settings” tab in Hello UI, or the “Settings” submenu of the “Config” tab in the Desktop UI.

Failure Alarms – Triggered when parameters fall outside pre-defined ranges, which indicates that sensors or other hardware have failed. For definitions of all alarms, see Appendix 2 on page 215.

All alarms can be configured in the “Alarms” configuration page on the Desktop UI. There are three settings for alarms on the PBS-15/80: Notify, Audible, and Email. Users can select all three alarm settings for all alarm variables.

Notify – If the selected alarm is triggered, an alert will appear in the “Alarms” tab of the Hello UI.

Audible – If the selected alarm is triggered and is also set to ‘Notify,’ the software will alert users to a failure by sounding the built-in buzzer. The sound of the buzzer can be adjusted by changing the “Buzzer Period” setting in the “Settings” tab of the Hello UI, or the “Settings” configuration page of the Desktop UI.

Email – If the selected alarm is triggered and is also set to ‘Notify,’ a notification email will be sent to the list of entered email addresses in the ‘Email List’ field of the “Alarms” configuration page of the Desktop UI. For more information on how to configure email settings, see the “Configure email notifications” step of “Creating and Editing Alarm Files” on page 72.

Users may acknowledge an alarm while the condition which triggered it is still being met. The alarm will regenerate once the amount of time specified in the Alarm “Snooze Time” setting has elapsed.

When a user clicks “Acknowledge All” to acknowledge all alarms, alarms of all types will be snoozed until the amount of time specified in the Alarm “Snooze Time” setting has elapsed. This also applies to alarm types which were not previously triggered.

For more information on acknowledging alarms, see “Alarms” on page 133. For information on changing the Alarm “Snooze Time,” see “Settings/System Variables” on page 134. For default alarms configurations, see Appendix 3 on page 220.

Settings

The System Variables configuration file (System Variables.sys) can be configured in the Desktop UI, or in the Hello UI's "Settings" tab. You can navigate to the "Settings" page in the Desktop UI by clicking the "Config" tab, and then selecting the "Settings" button. While some settings are meant to be user-configurable, it is possible to severely impair functionality of the PBS-15/80 by changing certain settings. For a complete list of all settings, their definitions, and whether PBS Biotech Technical Support recommends changing them, see Appendix 1 on page 188.

User Accounts

Users are required to log in with an individual user name and password to access both the Hello UI and the Desktop UI. Using remote clients, multiple users can log in to the Hello UI at the same time, and one user can be logged in to the Hello UI from multiple locations. Users can choose to log out of the Hello UI, and are logged out automatically after ten (10) minutes of inactivity. Only one user can log in to the Desktop UI at a time, and if they do not log out when they finish, they will be logged out after ten minutes of inactivity. Changes a user makes while they are logged in to either interface are recorded in the database and can be exported in a User Events report.

Use of shared or generic accounts is not recommended in regulated environments or when traceability of user actions is desired. Users in regulated environments are responsible for ensuring that any such use of accounts is managed appropriately.

Users have user names, passwords, user groups, and optional email addresses to receive emailed reports. For information on configuring users and user groups, see "Configuring Users and Groups" on page 57.

User Group Permissions

Permission groups can be configured to have a combination of the following permission options:

Desktop User Interface Permissions

These control access to the features in the Desktop UI. They do not affect permissions in the Hello UI.

Alarms Editor – Allows users to configure alarms to be set to Notify, Audible, and/or Email, as well as advanced email settings. When this permission is not granted, the "Alarm" option under the "Config" button in the

Desktop UI is grayed out and cannot be selected. Alarms permissions in the Hello UI are not affected.

Logger Editor – Allows users to configure what data is recorded and how often. When this permission is not granted, the “Logger” option under the “Config” button in the Desktop UI is grayed out and cannot be selected.

Settings Editor – Allows users to edit the values of system variables. When this permission is not granted, the “Settings” button under the “Config” option is grayed out and cannot be selected. It should be noted that settings can still be edited through the Hello UI if the user has the “Hello Access” and “Hello Settings” permissions under the Hello User Interface permissions.

Recipe Editor – Allows users to add and edit recipes. When this permission is not granted, the “Recipe” button under “Config” is grayed out and cannot be selected. The ability to start or stop recipes in the Hello UI is not affected.

Advanced Calibration – Allows users to calibrate the pH, DO, temperature, filter oven, pressure, level, and MFCs. It also allows users to enter calibration slope and intercept values manually, but this should not be done without consulting PBS Biotech Technical Support. When this permission is not granted, the “Calibration” button under “Config” is grayed out and cannot be selected.

DB Management – Allows users to archive the current database, copy databases onto external drives, delete archived databases, and map networked drives.

Account Management – Allows users to configure Users and User Groups settings, including permissions, password expiration periods, emails, assigned User Groups, and names. When this permission is not granted, the user only has access to “Edit User” under Account → Manage, and can only change the password and email address associated with their own account.

Hello User Interface Permissions

These permissions control access to the Hello UI:

Hello Access – Allows users to log in to the Hello UI. When this permission is not granted, the users assigned to the group do not appear on the Login menu of the Hello UI.

Remote Access – Allows users to log in to the Hello UI using a remote client. When this permission is not granted, the users assigned to the group do not appear on the Login list in the remote client, but do appear on the bioreactor and on LogMeIn.

Door – Allows users to unlock the door. When this permission is not granted, the “Unlock Door” button under the “Actions” tab is grayed out and cannot be selected.

Light – Allows the user to turn the Main Light on and off. When this permission is not granted, the “Main Light” button under the “Actions” tab is grayed out and cannot be selected.

Batch – Allows users to start and end batches. When this permission is not granted, the “Batch” button under the “Actions” tab is grayed out and cannot be selected.

Recipe Start – Allows the user to start a recipe. When this permission is not granted, the “Auto Pilot” button under the “Actions” tab is grayed out and cannot be selected.

Recipe End – Allows the user to end a recipe that is currently running. When this permission is not granted, the “End” button in the “Auto Pilot” menu is grayed out and cannot be selected while a recipe is running.

Pumps – Allows the user to turn the pumps on and off, and change their direction and speed (if applicable).

Acknowledge Alarms – Allows the user to acknowledge alarms. When this permission is not granted, the user is unable to select any of the unacknowledged alarms under the “Alarms” tab.

Sensors – Allows users to perform applicable ‘one-point,’ ‘two-point,’ ‘zero,’ and ‘span’ calibrations on the DO, pH, and level sensors, ‘zero’ calibrations on the pressure sensor, and to use the Load Bag menu. When this permission is not granted, the “Calibrate” button under the “Actions” tab, and the “Load Bag” button in the “Load Bag” menu are grayed out and cannot be selected.

Hello Settings – Allows users to change the values of system variables. When this permission is not granted, users are unable to select the individual system variables to change them under the “Settings” tab, although they are able to view them.

Common Permissions

These permissions are shared by both the Desktop UI and the Hello UI.

Reports – Allows users to create and export reports. When this permission is not granted, the “Export Data” button in the Hello UI is grayed out and cannot be selected, as is the “Reports” button in the Desktop UI.

Controls – Allows users to set agitation, temperature, DO, pH, main gas, filter oven, and base pump. When this permission is not granted, the user is unable to select the corresponding buttons in the Dashboard and

“Pumps” menu of the Hello UI, and the “Requested Mode,” “Auto Set Point (°C),” and “Manual Duty (%)” options under “FiltOven” in the “Graph” tab in the Desktop UI are grayed out and cannot be selected.

System Management – In the Desktop UI, this allows users to rename the bioreactor, reboot the RIO, sync the RIO time, test the alarm buzzer, and restart the RIO. It also allows the user to shutdown, reboot, and log off of the Windows/HMI computer. In the Hello UI, it allows the user to shutdown or restart the Windows/HMI computer. When this permission is not granted, the “Shutdown” button under the Actions tab in the Hello UI is grayed out and cannot be selected, as is the “System” button in the Desktop UI.

Oxygen Flow Valve

The oxygen flow valve allows users to change the method of delivering O₂ to the bag by switching between the Main-gas line or the Micro-gas line. When the valve is set to “Overlay,” O₂ is mixed with the other gases that enter the bag through the Main-gas line into the overlay, and setting it to “Sparger” sparges pure O₂ through the Micro-gas line at the bottom of the bag.

While sparging O₂ is more efficient and allows higher rates of gas transfer due to the higher surface area to volume ratio of the sparged bubbles compared to the overlay, it may also cause foaming in the bag, which can damage cells. To reduce cell damage, PBS Biotech generally recommends that users only set the valve to “Sparger” when O₂ delivery through the overlay is insufficient to meet oxygen demand. This condition is reached when the O₂ flow has reached maximum output and the DO PV begins to drop. For information on O₂ output, see “Output Ranges” on page 148.

As there are no sensors to inform the software of the O₂ valve setting, users must always turn DO off before changing from “Overlay” to “Sparger” in order to activate the ‘slow start’ gas flow feature. This prevents a sudden surge of pressure within the Micro-gas line that may damage the sparger.

When changing from overlay O₂ to sparging, or vice versa, it is necessary to change the DO “O₂ P Gain (%/DO%),” “O₂ I Time (min),” and “O₂ D Time (min)” settings to account for the differences in the rate and mechanism of O₂ delivery.

This chapter contains information a customer's IT department may need to install or maintain the PBS-15/80.

Bioreactor Computer Architecture

- The control system of the PBS-15/80 Vertical-Wheel® Bioreactor System (PBS-15/80) is accessed through a touchscreen HMI located on the front of the bioreactor housing. Internally, an industrial process computer (IPC) controls UI, data, and configuration, while equipment control and monitoring is performed by an industrial automation controller (RIO)
- The IPC operates PBS Biotech's Hello UI software. This software is responsible for:
 - User Interfaces, including control panel, readouts, and configuration
 - Data and event logging
 - Enforcing data integrity and security, including access controls and audit trails
 - Sending emails
 - Sending user commands to the RIO controller
- The RIO controller is in charge of:
 - Sensing and control functions
 - Process monitoring, including interlocks and equipment failures
 - Generating the data and event records logged by the PBS Software
 - Running the Recipe engine

Operating System

The IPC runs on Windows Embedded Standard 7. Access to the operating system is granted to provide access to specific functions not implemented in the Hello UI application:

- Date/Time configuration
- NTP server configuration
- Manual import/export of configuration files
- Database archiving
- Static IP configuration

Access to the OS may also be used for configuration and security auditing.

NOTICE PBS Bioreactors are provided with a fully configured, embedded software package. PBS Biotech can only support system modifications made through the Hello UI or performed by PBS Biotech. Installation of any third-party software to the system may void the warranty and cause unexpected failures and data loss.

BIOS

The IPC's BIOS is configured at the factory to prevent booting from any media other than the hard drive installed on the PBS-15/80. The BIOS must not be configured to allow booting from any other media. This is to prevent a malicious user from gaining access to the database files and modifying or deleting records, thus violating GMP standards for data integrity.

Reconfiguring the BIOS may result in loss of functionality and compromise data integrity.

The BIOS is provided with a secure, factory default password. It may be changed for security purposes, but this is unnecessary for general use and must be done with extreme caution.

NOTICE To maintain data integrity, internal access to the bioreactor housing must be restricted to authorized personnel only. The BIOS security configuration does not protect against intentional misuse by a person with physical access to the IPC's motherboard or SSD.

Email

- The PBS software can send emails for the following reasons:
 - To notify users about alarms
 - * The active Alarm file must be configured for the alarm to be 'Notify'
 - * The email settings file must be configured for the alarm to be 'Email'
 - * Either the Alarm Emailing Snooze Time is 0, or more time has passed since the last alarm of that type was emailed
 - * An email is sent to every address in the "Email List" in the Desktop UI → Config → Alarm menu
 - To notify users about failed login attempts
 - * The user account will receive an email if it has an associated email address
 - * All user accounts with the "Account Management" permission and which have an associated email address will receive an email
 - To send report files to users
 - * A user who generates a report in the Hello UI will receive an email if their account has an associated email address

- The network must allow access to an SMTP relay configured in the bioreactor's Alarms editor.

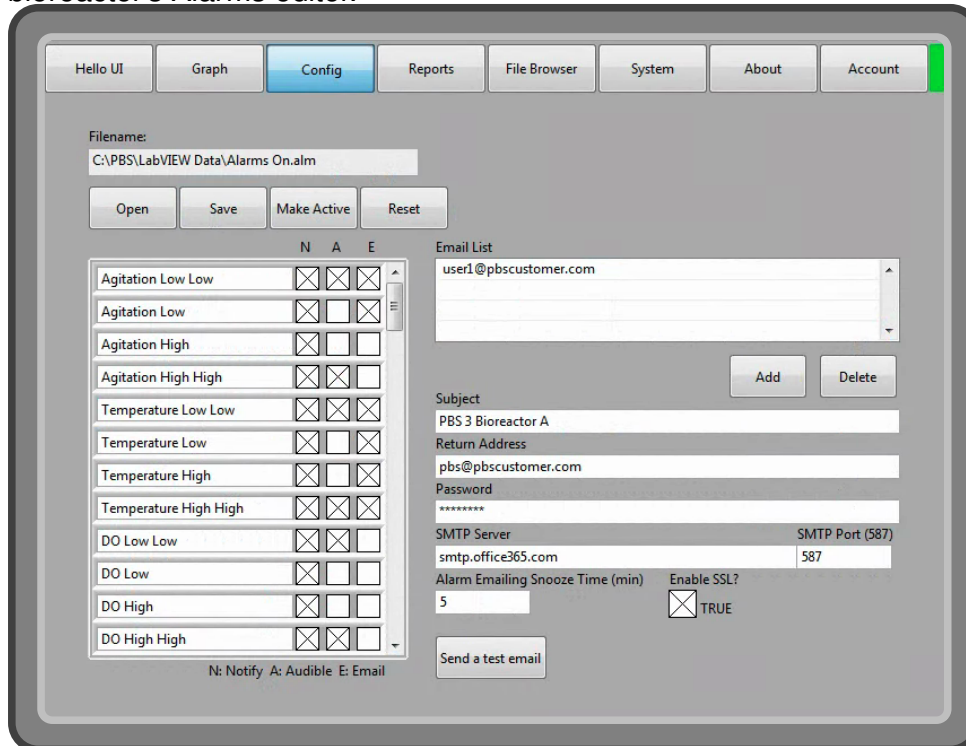

- Troubleshooting:
 - The PBS Error log may contain additional information regarding errors encountered when configuring SMTP settings.
 - Additional network-level configurations may be necessary to ensure email can be sent.
- Bioreactors are shipped with a default SMTP server configuration using an @pbscustomer.com email specific to the customer.
 - There is an attachment size limit of 35 MB for the default sending email address. Process data reports may be too large to be emailed, depending on the date range.
- SMS and MMS Gateways:
 - Users can receive alarm notifications as text messages, if the configured SMTP server supports SMS or MMS Gateway.
 - NOTICE** The default SMTP relay provided by PBS Biotech is not guaranteed to support SMS or MMS.
 - This requires entering the user's mobile phone number as an email address using the SMS gateway domain or MMS gateway domain of their mobile carrier. For example, 8055557272@txt.att.net would

be used to send a message to an AT&T mobile with number +1 805-555-7272.

- The Wikipedia “SMS gateway” page has more information, including a list of gateway domains for US and Canadian carriers:
https://en.wikipedia.org/wiki/SMS_gateway#Email_clients

Remote Access (not LogMeIn)

- Computers on the same LAN as the bioreactor can access the Hello User Interface by pointing Google Chrome at
<https://<IP Address>/webservice/hello.html>
 - Configuring the bioreactor’s IPC to have a static IP on the LAN is recommended for this reason (see “Network Connections” on page 182)
- Because the certificate is self-signed by the Server on the IPC, Google Chrome will likely show a security alert, but this can be ignored.
- If users wish to access the Hello User Interface even when they are not on the same LAN, the IT department can either set up a VPN or port forwarding.
- If users do not wish for the Hello User Interface to be accessible remotely, they can simply remove the “Hello User Interface – Remote Access” permission from all user groups. The Hello User Interface will still load on Google Chrome on a computer on the same LAN as the bioreactor, but users will not be able to log in or perform any actions.

Backups

- The PBS software automatically backs up the Database folders to the root of the Z: drive. The PBS software offers an interface to users to map a network location to the Z: drive, which should be used instead of configuring “net use” directly.
- Backing up to a physical drive:
 - If users desire to back up to a physical drive, configure Disk Management to recognize the physical drive as the Z: drive.
- Backing up to a network location:
 - If users desire to back up to a network location, the interface in the PBS Desktop UI should be used, by a user account with the “DB Access” permission. Log in and click “File Browser” → “Map Drive.”

- The “DELETE ALL” button in the “Map Drive” menu will remove all mapped network drives (including those configured with “net use” or some other method), not just those mapped using PBS software.
- The network configuration may need to be changed to successfully map a network drive - see “Network Connections” on page 182.
- The bioreactor ships with its “Backup Period (hour)” field in the “File Browser” menu set to 0, which disables automatic backups. Be sure to change this number after a Z: drive is made available.

McAfee Application and Change Control

- This is the security software used by the PBS-15/80
- It prevents non-whitelisted software from modifying the contents of the write-protected locations
 - For the GMP configuration, these are:
 - * C:\Database
 - * C:\PBS
 - * C:\Reports
 - For the R&D configuration, these are:
 - * C:\Database
 - * C:\PBS\builds
 - * C:\PBS\LabVIEW Data\System Variables.sys
 - * C:\Reports
- It is configured to allow Windows Updates, Google Chrome, and LogMeIn to update their own software
- Contact PBS Biotech Technical Support for the password. GMP users of the bioreactor should not have access to this password.
- Commands
 - To install new software, or make modifications to the write-protected locations (these are listed above, although **modifying anything in write-protected locations is a violation of GMP compliance**):
 - * Take the computer offline
 - * Enter **sadmin bu** in the command line editor (begin update)
 - * Install the desired software with an offline method
 - * Enter **sadmin eu** in the command line editor (end update)
 - * Put the computer back online

- To allow software to update itself:
 - * Enter **sadmin updaters add <application>** in the command line editor, replacing <application> with either the path to the application, or the name of the .exe.
- To see a list of software allowed to perform updates:
 - * Enter **sadmin updaters list** in the command line editor.
- To change the password:
 - * Enter **sadmin passwd -d** in the command line editor to remove the current password.
 - * Enter **sadmin passwd** to add a new password
- For more information, see McAfee Support for McAfee Application and Change Control.

Automatic Updates

- LogMeIn
 - As stated in “McAfee Application and Change Control” on page 186, McAfee is configured to allow LogMeIn to automatically update itself, provided it has access to the internet.
 - Preventing these automatic updates is not recommended.
- Windows
 - Windows is configured to automatically install updates.
 - If desired, this can be changed in the control panel.
- Google Chrome
 - Google Chrome is able to update itself automatically, provided it has access to the internet.
 - Preventing these automatic updates will require collaborating with PBS Biotech Technical Support to determine the best course of action.

While all system variable settings can technically be changed by the user, many should remain in their default values unless advised by PBS Biotech Technical Support, or unless the user is confident they know what they are doing. Consult the “User May Change” column to determine which of the following categories each system variable falls into:

- X = Should always remain in default value. Do not change unless specifically instructed by PBS Biotech Technical Support.
- ✓ = User may change from default value.
- ! = Use caution. User must be familiar with bioreactor operations. If in doubt, consult PBS Biotech Technical Support.
- N/A = Not applicable for this bioreactor model.

TEMPERATURE

Setting Name	Default Value		Definition	User May Change	Corresponding Global Variable
	PBS-15	PBS-80			
P Gain (%/C)	70.000	60.000	Proportional Gain for the temperature controller.	!	TempHeatDutyControl.PGain (min)
I Time (min)	15.000	20.000	Integral Time for the temperature controller.	!	TempHeatDutyControl.ITime (min)
D Time (min)	0.000	0.000	Derivative Time for the temperature controller.	!	TempHeatDutyControl.DTime (min)
Alpha	-1.000	-1.000	Specifies the derivative filter time constant. Increasing this value increases damping of derivative action. It can be a value between 0 and 1, or less than 0, which specifies that no derivative filter is applied.	X	TempHeatDutyControlAlpha
Beta	0.000	0.000	Specifies the relative emphasis of set point tracking to disturbance rejection.	X	TempHeatDutyControlBeta

TEMPERATURE (continued)

Setting Name	Default Value		Definition	User May Change	Corresponding Global Variable
	PBS-15	PBS-80			
Gamma	0.000	0.000	Specifies an amount by which to weight the error applied to derivative action. A value of 0 avoids derivative kick, which is the sudden change in controller output that can occur after a change in the set point value.	X	TempHeatDutyControlGamma
Linearity	1.000	1.000	Specifies the linearity of the error response. The valid range is 0 to 1.	X	TempHeatDutyControlLinearity
Heat Manual Max (%)	50.000	100.000	The maximum main heater duty allowed in Manual mode.	!	TempHeatManMax(%)
Heat Auto Max (%)	50.000	100.000	The maximum main heater duty allowed in Auto mode.	!	TempHeatDutyAutoMax(%)
Valid High (C)	110.000	110.000	If a temperature sensor registers a measurement above this value, the software assumes the temperature sensor is broken, and triggers a Temperature Sensor Failure (range) Alarm.	!	TempValidMax(C)
Valid Low (C)	-5.000	-5.000	If a temperature sensor registers a measurement below this value, the software assumes the temperature sensor is broken, and triggers a Temperature Sensor Failure (range) Alarm.	!	TempValidMin(C)

TEMPERATURE (continued)

Setting Name	Default Value		Definition	User May Change	Corresponding Global Variable
	PBS-15	PBS-80			
Mismatch Thresh (C)	0.400	0.400	For Vertical-Wheel® Bioreactors with dual temperature sensors, if the sensors register measurements that differ by more than this amount, it triggers a Temperature Mismatch Alarm.	!	TempMismatch Thresh(C)

FILTER OVEN

Setting Name	Default Value		Definition	User May Change	Corresponding Global Variable
	PBS-15	PBS-80			
P Gain (%/C)	100.000	100.000	Proportional Gain for the filter oven controller.	X	FilterOvenDuty Control.Gain (%/C)
I Time (min)	0.030	0.030	Integral Time for the filter oven controller.	X	FilterOvenDuty Control.ITime (min)
D Time (min)	0.000	0.000	Derivative Time for the filter oven controller.	X	FilterOvenDuty Control.DTime (min)
Alpha	-1.000	-1.000	Specifies the derivative filter time constant. Increasing this value increases damping of derivative action. It can be a value between 0 and 1, or less than 0, which specifies that no derivative filter is applied.	X	FilterOvenDuty ControlAlpha
Beta	1.000	1.000	Specifies the relative emphasis of set point tracking to disturbance rejection.	X	FilterOvenDuty ControlBeta

FILTER OVEN (continued)

Setting Name	Default Value		Definition	User May Change	Corresponding Global Variable
	PBS-15	PBS-80			
Gamma	0.000	0.000	Specifies an amount by which to weight the error applied to derivative action. A value of 0 avoids derivative kick, which is the sudden change in controller output that can occur after a change in the set point value.	X	FilterOvenDutyControlGamma
Linearity	1.000	1.000	Specifies the linearity of the error response. The valid range is 0 to 1.	X	FilterOvenDutyControlLinearity
Heat Manual Max (%)	50.000	50.000	The maximum filter oven heater duty allowed in Manual mode.	X	FilterOvenDutyRangeManMax (%)
Heat Auto Max (%)	80.000	50.000	The maximum filter oven heater duty allowed in Auto mode.	X	FilterOvenDutyRangeAutoMax (%)

AGITATION

Setting Name	Default Value		Definition	User May Change	Corresponding Global Variable
	PBS-15	PBS-80			
P Gain (%/RPM)	0.060	0.100	Proportional Gain for the agitation controller.	!	AgPowerControl.PGain (%/RPM)
I Time (min)	0.010	0.010	Integral Time for the agitation controller.	!	AgPowerControl.ITime (min)
D Time (min)	0.000	0.000	Derivative Time for the agitation controller.	!	AgPowerControl.DTime (min)

AGITATION (continued)

Setting Name	Default Value		Definition	User May Change	Corresponding Global Variable
	PBS-15	PBS-80			
Alpha	-1.000	-1.000	Specifies the derivative filter time constant. Increasing this value increases damping of derivative action. It can be a value between 0 and 1, or less than 0, which specifies that no derivative filter is applied.	X	AgControlAlpha
Beta	0.000	0.000	Specifies the relative emphasis of set point tracking to disturbance rejection.	X	AgControlBeta
Gamma	0.000	0.000	Specifies an amount by which to weight the error applied to derivative action. A value of 0 avoids derivative kick, which is the sudden change in controller output that can occur after a change in the set point value.	X	AgControlGamma
Linearity	1.000	1.000	Specifies the linearity of the error response. The valid range is 0 to 1.	X	AgControlLinearity
Minimum (RPM)	3.000	3.000	If the agitation rate is below this value the software will consider the agitation PV = 0.	!	AgMin(RPM)

AGITATION (continued)

Setting Name	Default Value		Definition	User May Change	Corresponding Global Variable
	PBS-15	PBS-80			
Pulse Mode Timeout (s)	60.000	60.000	If the software fails to detect agitation in Auto mode for this length of time, it goes into Pulse mode. Should be set equal to the Agitation “Lookup Mode Timeout (s)” setting, to disable Pulse Mode.	✓	AgPulseMode Timeout(ms)
Lookup Mode Timeout (s)	60.000	60.000	If the software fails to detect agitation in Auto mode for this length of time, it goes into Lookup mode. Should be set equal to the Agitation “Pulse Mode Timeout (s)” setting, to disable Pulse Mode.	✓	AgLookupMode Timeout (ms)
Lookup Factor (%/RPM)	1.799	2.924	In Lookup mode, the agitation set point is multiplied by this factor to determine the power output to be used.	✓	AgPwrLookup Factor(%/RPM)
Power Auto Max (%)	100.000	100.000	The maximum power output allowed in Auto mode while the PV is above 0.	✓	AgPowerRange Auto(%).Max
Power Auto Min (%)	3.500	3.500	The minimum power output allowed in Auto mode.	!	AgPowerRange Auto(%).Min
Auto Max Startup (%)	10.000	20.000	The maximum power output allowed in Auto mode until the PV is above 0.	!	AgAutoMax Startup(%)
Power Manual Max (%)	100.000	100.000	The maximum power output allowed in Manual mode.	✓	AgPowerRange ManMax(%)

AGITATION (continued)

Setting Name	Default Value		Definition	User May Change	Corresponding Global Variable
	PBS-15	PBS-80			
Number of Magnets	2.000	2.000	The number of magnets on the Vertical-Wheel® impeller.	!	AgWheelMagnet Count
Samples To Average	3.000	3.000	The number of time periods averaged when calculating the agitation.	X	AgWheelSamples ToAverage

pH

Setting Name	Default Value		Definition	User May Change	Corresponding Global Variable
	PBS-15	PBS-80			
Mismatch Thresh	N/A	N/A	For Vertical-Wheel® Bioreactors with dual pH sensors, if the sensors register measurements that differ by more than this amount, it triggers a pH Mismatch Alarm.	N/A	pHMismatch Thresh
Rate Fail Delta PV	1.000	1.000	If the pH changes by more than this value in the pH “Rate Fail Delta Time (s)” time, the software assumes the pH sensor is broken, and triggers a “pH Sensor Failure (rate)” alarm.	✓	pHRateFailDelta PV
Rate Fail Delta Time (s)	60.000	60.000	If the pH changes by more than the pH “Rate Fail Delta PV” value in this time, the software assumes the pH sensor is broken, and triggers a “pH Sensor Failure (rate)” alarm.	✓	pHRateFailDelta Time(ms)
CO2 P Gain (%/pH)	-200.000	-200.000	Proportional Gain for the pH CO ₂ controller.	!	pHCO ₂ Control.PGain(%)

pH (continued)

Setting Name	Default Value		Definition	User May Change	Corresponding Global Variable
	PBS-15	PBS-80			
CO2 I Time (min)	10.000	10.000	Integral Time for the pH CO ₂ controller.	!	pHCO ₂ Control.ITime (min)
CO2 D Time (min)	0.000	0.000	Derivative Time for the pH CO ₂ controller.	!	pHCO ₂ Control.DTime (min)
CO2 Alpha	-1.000	-1.000	Specifies the derivative filter time constant. Increasing this value increases damping of derivative action. It can be a value between 0 and 1, or less than 0, which specifies that no derivative filter is applied.	X	pHCO ₂ Control Alpha
CO2 Beta	1.000	1.000	Specifies the relative emphasis of set point tracking to disturbance rejection.	X	pHCO ₂ Control Beta
CO2 Gamma	0.000	0.000	Specifies an amount by which to weight the error applied to derivative action. A value of 0 avoids derivative kick, which is the sudden change in controller output that can occur after a change in the set point value.	X	pHCO ₂ Control Gamma
CO2 Linearity	1.000	1.000	Specifies the linearity of the error response. The valid range is 0 to 1.	X	pHCO ₂ Control Linearity
CO2 Manual Max (%)	100.000	100.000	The maximum CO ₂ composition in the main gas flow allowed in Manual mode.	✓	pHCO ₂ ManMax (%)

pH (continued)

Setting Name	Default Value		Definition	User May Change	Corresponding Global Variable
	PBS-15	PBS-80			
CO2 Auto Max (%)	30.000	30.000	The maximum CO ₂ composition in the main gas flow allowed in Auto mode.	✓	pHCO2AutoMax (%)
Base P Gain (%/pH)	10.000	10.000	Proportional Gain for the pH base controller.	!	pHBaseDuty Control.PGain(%)
Base I Time (min)	50.000	50.000	Integral Time for the pH base controller.	!	pHBaseDuty Control.ITime (min)
Base D Time (min)	0.000	0.000	Derivative Time for the pH base controller.	!	pHBaseDuty Control.DTime (min)
Base Alpha	-1.000	-1.000	Specifies the derivative filter time constant. Increasing this value increases damping of derivative action. It can be a value between 0 and 1, or less than 0, which specifies that no derivative filter is applied.	X	pHBaseDuty Control.Alpha
Base Beta	1.000	1.000	Specifies the relative emphasis of set point tracking to disturbance rejection.	X	pHBaseDuty Control.Beta
Base Gamma	0.000	0.000	Specifies an amount by which to weight the error applied to derivative action. A value of 0 avoids derivative kick, which is the sudden change in controller output that can occur after a change in the set point value.	X	pHBaseDuty Control.Gamma

pH (continued)

Setting Name	Default Value		Definition	User May Change	Corresponding Global Variable
	PBS-15	PBS-80			
Base Linearity	1.000	1.000	Specifies the linearity of the error response. The valid range is 0 to 1.	X	pHBaseDuty ControlLinearity
Base Manual Max (%)	100.000	100.000	The maximum base pump duty allowed in Manual mode.	✓	pHBaseDutyMan Max(%)
Base Auto Max (%)	50.000	50.000	The maximum base pump duty allowed in Auto mode.	✓	pHBaseAutoMax
A Use Temp Comp?	1.000	1.000	Use (1) or do not use (0) a temperature compensation factor for pH sensor A. Must be used for reusable pH sensors, and must not be used for single-use pH sensors.	X	pHAUseTemp Comp
B Use Temp Comp?	N/A	N/A	Use (1) or do not use (0) a temperature compensation factor for pH sensor B. Must be used for reusable pH sensors, and must not be used for single-use pH sensors.	N/A	pHBUseTemp Comp
Deadband	0.020	0.020	The internal deadband of the pH controller. CO ₂ only flows when the pH PV is greater than the pH set point + deadband. Base only flows when the pH PV is less than the pH set point - deadband.	✓	pHDeadband

pH (continued)

Setting Name	Default Value		Definition	User May Change	Corresponding Global Variable
	PBS-15	PBS-80			
Valid High (pH)	14.000	14.000	If a pH sensor registers a measurement above this value, the software assumes the pH sensor is broken, and triggers a pH Sensor Failure (range) Alarm.	!	pHValidMax
Valid Low (pH)	0.000	0.000	If a pH sensor registers a measurement below this value, the software assumes the pH sensor is broken, and triggers a pH Sensor Failure (range) Alarm.	!	pHValidMin

pH (continued)

Setting Name	Default Value		Definition	User May Change	Corresponding Global Variable
	PBS-15	PBS-80			
Samples To Average	10.000	10.000	The number of samples used to calculate a moving average of the pH signal. pH is sampled once per second, meaning a value of 10 Samples To Average corresponds to 10 seconds of data. Note: The corresponding global variable for this value is coerced between 1 and 3600 samples (inclusive). Note: Sampling data is reset when this setting is changed. Allow one second per sample (e.g. 10 seconds for 10 Samples To Average) for the setting to fully take effect. Note: This setting does not apply to data displayed in the Desktop UI's or Hello UI's calibration menu.	!	pHSensor SamplesTo Average

DO

Setting Name	Default Value		Definition	User May Change	Corresponding Global Variable
	PBS-15	PBS-80			
Mismatch Thresh (DO%)	N/A	N/A	For Vertical-Wheel® Bioreactors with dual DO sensors, if the sensors register measurements that differ by more than this amount, it triggers a DO Mismatch Alarm.	N/A	DOMismatch Thresh(%)

DO (continued)

Setting Name	Default Value		Definition	User May Change	Corresponding Global Variable
	PBS-15	PBS-80			
Valid High (DO%)	200.000	200.000	If a DO sensor registers a measurement above this value, the software assumes the DO sensor is broken, and triggers a DO Sensor Failure (range) Alarm.	!	DOValidMax(%)
Valid Low (DO%)	-10.000	-10.000	If a DO sensor registers a measurement below this value, the software assumes the DO sensor is broken, and triggers a DO Sensor Failure (range) Alarm.	!	DOValidMin(%)
O2 P Gain (%/DO%)			Proportional Gain for the DO O ₂ controller.	!	DOO2Control Mag.PGain(%/%)
Overlay:	7.000	3.000			
Sparger:	TBD	TBD			
O2 I Time (min)			Integral Time for the DO O ₂ controller.	!	DOO2Control Mag.ITime(min)
Overlay:	50.000	70.000			
Sparger:	TBD	TBD			
O2 D Time (min)			Derivative Time for the DO O ₂ controller.	!	DOO2Control Mag.DTime(min)
Overlay:	0.000	0.000			
Sparger:	TBD	TBD			

DO (continued)

Setting Name	Default Value		Definition	User May Change	Corresponding Global Variable
	PBS-15	PBS-80			
O2 Alpha	-1.000	-1.000	Specifies the derivative filter time constant. Increasing this value increases damping of derivative action. It can be a value between 0 and 1, or less than 0, which specifies that no derivative filter is applied.	X	DOO2Control Alpha
O2 Beta	0.000	0.000	Specifies the relative emphasis of set point tracking to disturbance rejection.	X	DOO2Control Beta
O2 Gamma	0.000	0.000	Specifies an amount by which to weight the error applied to derivative action. A value of 0 avoids derivative kick, which is the sudden change in controller output that can occur after a change in the set point value.	X	DOO2Control Gamma
O2 Linearity	1.000	1.000	Specifies the linearity of the error response. The valid range is 0 to 1.	X	DOO2Control Linearity
O2 Manual Max (%)	100.000	100.000	The maximum O ₂ composition in the main gas flow allowed in Manual mode.	✓	DOO2RangeMan Max(%)
O2 Auto Max (%)	100.000	100.000	The maximum O ₂ composition in the main gas flow allowed in Auto mode.	✓	DOO2RangeAuto Max(%)
N2 P Gain (%/DO%)	-6.000	-3.000	Proportional Gain for the DO N ₂ controller.	!	DON2 Control.PGain (%/%)

DO (continued)

Setting Name	Default Value		Definition	User May Change	Corresponding Global Variable
	PBS-15	PBS-80			
N2 I Time (min)	90.000	70.000	Integral Time for the DO N ₂ controller.	!	DON2Control.ITime (min)
N2 D Time (min)	0.000	0.000	Derivative Time for the DO N ₂ controller.	!	DON2Control.DTime (min)
N2 Alpha	-1.000	-1.000	Specifies the derivative filter time constant. Increasing this value increases damping of derivative action. It can be a value between 0 and 1, or less than 0, which specifies that no derivative filter is applied.	X	DON2Control Alpha
N2 Beta	0.000	0.000	Specifies the relative emphasis of set point tracking to disturbance rejection.	X	DON2Control Beta
N2 Gamma	0.000	0.000	Specifies an amount by which to weight the error applied to derivative action. A value of 0 avoids derivative kick, which is the sudden change in controller output that can occur after a change in the set point value.	X	DON2Control Gamma
N2 Linearity	1.000	1.000	Specifies the linearity of the error response. The valid range is 0 to 1.	X	DON2Control Linearity
N2 Manual Max (%)	100.000	100.000	The maximum N ₂ composition in the main gas flow allowed in Manual mode.	✓	DON2RangeMan Max(%)

DO (continued)

Setting Name	Default Value		Definition	User May Change	Corresponding Global Variable
	PBS-15	PBS-80			
N2 Auto Max (%)	100.000	100.000	The maximum N ₂ composition in the main gas flow allowed in Auto mode.	✓	DON2RangeAuto Max(%)
Deadband (DO%)	1.000	1.000	The internal deadband of the DO controller. N ₂ set point is DO set point + deadband, and O ₂ set point is DO set point - deadband.	✓	DODeadband(%)

LEVEL

Setting Name	Default Value		Definition	User May Change	Corresponding Global Variable
	PBS-15	PBS-80			
Radius (cm)	13.750	24.500	The radius of the base of the chamber. This is used in the nonlinear level calculation.	X	LevelCal Cluster.Radius (cm)
Empty Level (V)	0.000	0.000	If the level sensor is below this voltage, the system recognizes the level PV = 0.	!	LevelCal Cluster.Level Empty(V)
Empty Level (L)	1.500	8.000	If the level PV is below this value, the software recognizes the level PV = 0.	!	LevelCal Cluster.Level Empty(L)
cm/psi	70.358	70.358	The conversion from the pressure the level sensor reports to the height of the liquid. This is used in the nonlinear level calculation.	!	LevelCal Cluster.Cm/psi
Vessel Depth (cm)	15.300	26.000	The distance from the back of the chamber to the door. This is used in the nonlinear level calculation.	X	LevelCal Cluster.Depth

LEVEL (continued)

Setting Name	Default Value		Definition	User May Change	Corresponding Global Variable
	PBS-15	PBS-80			
Bottom Gap (cm)	0.000	0.000	Gap at the bottom of the chamber unaccounted for by the level sensor.	X	LevelCal Cluster.Bottom Gap (cm)
Enable Sensor (0 or 1)	1.000	1.000	If the level sensor is enabled (1), the "Level" box is displayed in the dashboard and all level-related interlocks are in place. Disabled (0), there is no "Level" box in the dashboard, and no level-related interlocks.	✓	LevelSensor Enable
CalLevelSlope Max(psi/V)	10000	10000	The maximum level slope value allowed during calibration.	!	CalLimits Level.CallLevel SlopeMax(psi/V)
CalLevelSlope Min(psi/V)	-10000	-10000	The minimum level slope value allowed during calibration.	!	CalLimits Level.CallLevel SlopeMin(psi/V)
CalLevel InterceptMax (psi)	10000	10000	The maximum level intercept value allowed during calibration.	!	CalLimits Level.CallLevel InterceptMax(psi)
CalLevel InterceptMin (psi)	-10000	-10000	The minimum level intercept value allowed during calibration.	!	CalLimits Level.CallLevel InterceptMin(psi)

PRESSURE

Setting Name	Default Value		Definition	User May Change	Corresponding Global Variable
	PBS-15	PBS-80			
Disconnected Pressure (V)	1.000	1.000	If the absolute value of the voltage associated with pressure PV is greater than the disconnected pressure voltage, the software recognizes the pressure sensor is disconnected.	X	Pressure Disconnected(V)
CalPressure InterceptMax (psi)	1.500	1.500	The maximum pressure intercept value allowed during calibration.	!	Callimits Pressure.Cal PressureIntercept Max(psi)
CalPressure InterceptMin (psi)	-1.500	-1.500	The minimum pressure intercept value allowed during calibration.	!	Callimits Pressure.Cal PressureIntercept Min(psi)
CalPressure SlopeMax (psi/V)	250.000	250.000	The maximum pressure slope value allowed during calibration.	!	Callimits Pressure.Cal PressureSlope Max(psi/V)
CalPressure SlopeMin (psi/V)	150.000	150.000	The minimum pressure slope value allowed during calibration.	!	Callimits Pressure.Cal PressureSlope Min(psi/V)
Reusable Sensor (0 or 1)	1.000	1.000	Tells the software what kind of pressure sensor is used on the bioreactor.	X	Reusable Sensor (0 or 1)

GAS DATA

Setting Name	Default Value		Definition	User May Change	Corresponding Global Variable
	PBS-15	PBS-80			
CO2 Min (LPM)	0.030	0.080	This corresponds to the shutoff flowrate of the CO ₂ MFC - the MFC cannot flow reliably below this rate. Any requested flows below this will be delivered by the software as time metered pulses at this flow rate.	X	MFCCO2Min (LPM)
CO2 Off (V)	0.000	0.000	This is the voltage sent to the CO ₂ MFC when no gas flow is being requested.	X	MFCCO2Off(V)
N2 Min (LPM)	0.100	0.250	This corresponds to the shutoff flowrate of the N ₂ MFC - the MFC cannot flow reliably below this rate. Any requested flows below this will be delivered by the software as time metered pulses at this flow rate.	X	MFCN2Min(LPM)
N2 Off (V)	0.000	0.000	This is the voltage sent to the N ₂ MFC when no gas flow is being requested.	X	MFCN2Off(V)
Air Min (LPM)	0.100	0.250	This corresponds to the shutoff flowrate of the Air MFC - the MFC cannot flow reliably below this rate. Any requested flows below this will be delivered by the software as time metered pulses at this flow rate.	X	MFCAirMin(LPM)

GAS DATA (continued)

Setting Name	Default Value		Definition	User May Change	Corresponding Global Variable
	PBS-15	PBS-80			
Air Off (V)	0.000	0.000	This is the voltage sent to the Air MFC when no gas flow is being requested.	X	MFCAirOff(V)
O2 Min (LPM)	0.030	0.300	This corresponds to the shutoff flowrate of the O ₂ MFC - the MFC cannot flow reliably below this rate. Any requested flows below this will be delivered by the software as time metered pulses at this flow rate.	X	MFCO2Min(LPM)
O2 Off (V)	0.000	0.000	This is the voltage sent to the O ₂ MFC when no gas flow is being requested.	X	MFCO2Off(V)
PWM On Time (s)	10.000	10.000	Pulse Width Modulation On Time of the MFCs.	!	MFCOnTime(s)
PWM Max Period (s)	200.000	500.000	Maximum Pulse Width Modulation Period of the MFCs (period may be smaller, depending on pulsing called for and Gas Data "PWM On Time (s)" setting.	!	MFCMaxPeriod (s)
Mismatch Thresh (V)	0.100	0.100	If the voltage the software requests the MFC to deliver is different from the actual voltage the MFC delivers by this value or more, it triggers a Source Pressure Error Alarm.	✓	MFCMismatch Thresh(V)

GAS DATA (continued)

Setting Name	Default Value		Definition	User May Change	Corresponding Global Variable
	PBS-15	PBS-80			
O2 Min Volume (L)	0.010	0.060	O ₂ cannot flow above the MFC's minimum until at least this much net volume of O ₂ has flowed since turning DO on. This is known as the "O ₂ Slow Start" feature.	!	O2 Min Volume (L)
Manual Max (LPM)	2.000	10.000	The maximum main gas flow allowed in Manual mode.	✓	MainGasRange ManMax(LPM)

SAFETY

Setting Name	Default Value		Definition	User May Change	Corresponding Global Variable
	PBS-15	PBS-80			
Min Ag Power (%)	10.000	10.000	If the agitation PV = 0 but the power output to the agitation motor is greater than this value, the software will assume the agitation sensor is broken, and will not interlock the main heater.	X	AgMinPower(%)
Max Temp (C)	45.000	45.000	The main heater will be interlocked if temperature PV exceeds this temperature.	✓	InterlockTemp Max(C)
Max Pressure (psi)	0.500	0.500	The software will stop gas flow and pump activity if the pressure PV exceeds this pressure.	X	InterlockPressure Max(psi)
Max Pressure Door (psi)	0.100	0.100	The software will not allow the door to be unlocked if pressure PV exceeds this pressure.	X	InterlockDoor PressureMax(psi)

SAFETY (continued)

Setting Name	Default Value		Definition	User May Change	Corresponding Global Variable
	PBS-15	PBS-80			
Min Level (L)	4.000	10.000	The minimum level below which the temperature controller will be interlocked to avoid heating an empty bag or heating in the absence of a bag.	X	LevelMin(L)
Max Level (L)	17.000	85.000	The maximum level, above which the temperature controller will be interlocked to avoid heating an overfilled bag. Additionally, pumps will be interlocked to avoid overfilling.	X	LevelMax(L)
Buzzer Period (ms)	100.000	100.000	This value affects the quality of sound of the alarm buzzer.	✓	AlarmBuzzer Period(Cycle)
DoorPressure Sensor (0 or 1)	0.000	0.000	Tells the software the bioreactor has a door pressure sensor.	X	DoorPressure Sensor

PUMPS

Setting Name	Default Value		Definition	User May Change	Corresponding Global Variable
	PBS-15	PBS-80			
Aux Low Duty			At “Slow” speed, a small addition pump will give this many “on” pulses out of 2^{16} , or 65,536 pulses in total.	✓	Pumps&Valves PumpLowAux Speed
sbRIO* 9641 or 9642:	20000	20000			
sbRIO* 9603:	30000	30000			
Aux Med Duty			At “Medium” speed, a small addition pump will give this many “on” pulses out of 2^{16} , or 65,536 pulses in total.	✓	Pumps&Valves PumpMedAux Speed
sbRIO* 9641 or 9642:	30000	30000			
sbRIO* 9603:	52000	52000			
Base On Time (s)	0.100	0.100	The base pump turns on in increments of this number.	!	Pumps&Valves BaseOnTime(s)
Base Max Period (s)	240.000	240.000	Maximum base pump period (period may be smaller, depending on base pump duty called for and Pumps “Base On Time (s)” setting.	!	Pumps&Valves BaseMaxPeriod (s)
Analog Base Speed (RPM)	N/A	N/A	For models with analog Additions pumps, when the base pump turns on, it is set to this RPM value. A higher Pumps “Base On Time (s)” setting makes it more likely the pump can reach a higher RPM.	N/A	Pumps&Valves AnalogBase Speed(RPM)
Sample Reverse CW and CCW (0 or 1)	0.000	0.000	This value affects the rotation direction of the sample motor.	X	Pumps&Valves ReverseCCand CW

* The sbRIO model is displayed in the Desktop UI About tab.

PROCESS ALARMS

These values are meant to be user configurable and used as process deviation alarms. If the PVs exceed the values, alarm events will be triggered.

Setting Name	Default Value		Definition	User May Change	Corresponding Global Variable
	PBS-15	PBS-80			
Agitation Low Low (RPM)	3.000	7.000	If the PV is below this value, the alarm state is "error."	✓	Limits.Agitation Low Low (RPM)
Agitation Low (RPM)	10.000	9.000	If the PV is below this value, the alarm state is "warning."	✓	Limits.Agitation Low (RPM)
Agitation High (RPM)	35.000	18.000	If the PV is above this value, the alarm state is "warning."	✓	Limits.Agitation High (RPM)
Agitation High High (RPM)	38.000	20.000	If the PV is above this value, the alarm state is "warning."	✓	Limits.Agitation High High (RPM)
Temp Low Low (C)	35.000	35.000	If the PV is below this value, the alarm state is "error."	✓	Limits.Temp Low Low (C)
Temp Low (C)	36.000	36.000	If the PV is below this value, the alarm state is "warning."	✓	Limits.Temp Low (C)
Temp High (C)	38.000	38.000	If the PV is above this value, the alarm state is "warning."	✓	Limits.Temp High (C)
Temp High High (C)	39.000	39.000	If the PV is above this value, the alarm state is "warning."	✓	Limits.Temp High High (C)
DO Low Low (%)	30.000	30.000	If the PV is below this value, the alarm state is "error."	✓	Limits.DO Low Low (%)
DO Low (%)	40.000	40.000	If the PV is below this value, the alarm state is "warning."	✓	Limits.DO Low (%)
DO High (%)	60.000	60.000	If the PV is above this value, the alarm state is "warning."	✓	Limits.DO High (%)
DO High High (%)	70.000	70.000	If the PV is above this value, the alarm state is "warning."	✓	Limits.DO High High (%)

PROCESS ALARMS (continued)

Setting Name	Default Value		Definition	User May Change	Corresponding Global Variable
	PBS-15	PBS-80			
pH Low Low	7.100	7.100	If the PV is below this value, the alarm state is "error."	✓	Limits.pH Low Low
pH Low	7.150	7.150	If the PV is below this value, the alarm state is "warning."	✓	Limits.pH Low
pH High	7.250	7.250	If the PV is above this value, the alarm state is "warning."	✓	Limits.pH High
pH High High	7.300	7.300	If the PV is above this value, the alarm state is "warning."	✓	Limits.pH High High
Pressure Low Low (psi)	-1.000	-1.000	If the PV is below this value, the alarm state is "error."	✓	Limits.Pressure Low Low (psi)
Pressure Low (psi)	-0.500	-0.500	If the PV is below this value, the alarm state is "warning."	✓	Limits.Pressure Low (psi)
Pressure High (psi)	0.200	0.200	If the PV is above this value, the alarm state is "warning."	✓	Limits.Pressure High (psi)
Pressure High High (psi)	0.300	0.300	If the PV is above this value, the alarm state is "warning."	✓	Limits.Pressure High High (psi)
Level Low Low (L)	4.000	10.000	If the PV is below this value, the alarm state is "error."	✓	Limits.Level Low Low (L)
Level Low (L)	7.000	35.000	If the PV is below this value, the alarm state is "warning."	✓	Limits.Level Low (L)
Level High (L)	15.000	80.000	If the PV is above this value, the alarm state is "warning."	✓	Limits.Level High (L)
Level High High (L)	17.000	85.000	If the PV is above this value, the alarm state is "warning."	✓	Limits.Level High High (L)
Filter Oven Low Low (C)	33.000	33.000	If the PV is below this value, the alarm state is "error."	✓	Limits.Filter Oven Low Low (C)

PROCESS ALARMS (continued)

Setting Name	Default Value		Definition	User May Change	Corresponding Global Variable
	PBS-15	PBS-80			
Filter Oven Low (C)	35.000	35.000	If the PV is below this value, the alarm state is "warning."	✓	Limits.Filter Oven Low (C)
Filter Oven High (C)	41.000	41.000	If the PV is above this value, the alarm state is "warning."	✓	Limits.Filter Oven High (C)
Filter Oven High High (C)	43.000	43.000	If the PV is above this value, the alarm state is "warning."	✓	Limits.Filter Oven High High (C)
Main Gas Low Low (LPM)	0.200	1.000	If the PV is below this value, the alarm state is "error."	✓	Limits.Main Gas Low Low (LPM)
Main Gas Low (LPM)	0.400	2.000	If the PV is below this value, the alarm state is "warning."	✓	Limits.Main Gas Low (LPM)
Main Gas High (LPM)	1.600	8.000	If the PV is above this value, the alarm state is "warning."	✓	Limits.Main Gas High (LPM)
Main Gas High High (LPM)	1.800	9.000	If the PV is above this value, the alarm state is "warning."	✓	Limits.Main Gas High High (LPM)

SYSTEM

Setting Name	Default Value		Definition	User May Change	Corresponding Global Variable
	PBS-15	PBS-80			
Max Data Log Interval (min)	60.000	60.000	This is the maximum time that will elapse between the logging of two subsequent timepoints of a logged variable. This is in addition to the logging by deadband as configured in the logger settings file.	✓	LoggerMaxLog Interval(ms)

SYSTEM (continued)

Setting Name	Default Value		Definition	User May Change	Corresponding Global Variable
	PBS-15	PBS-80			
Alarm Snooze Time (s)	300.000	300.000	If a Process Alarm is audible, acknowledging the alarm will silence the buzzer for the given period of time.	✓	AlarmSnooze Time(ms)
Available Mem Limit (KB)	2000	2000	If available memory on the RIO computer is less than this value, the "RT Mem Nearly Full" alarm is triggered.	X	SysAvailableMem Limit(KB)
LCB Mem Limit (KB)	2000	2000	If available LCB on the RIO is less than this value, the "RT Mem Fragmented" alarm is triggered.	X	SysLCBMemLimit (KB)

Alarms Definitions

Alarm Name	Alarm is Triggered When:
Agitation Low Low	Agitation PV drops below this value.
Agitation Low	Agitation PV drops below this value.
Agitation High	Agitation PV rises above this value.
Agitation High High	Agitation PV rises above this value.
Temperature Low Low	Temperature PV drops below this value.
Temperature Low	Temperature PV drops below this value.
Temperature High	Temperature PV rises above this value.
Temperature High High	Temperature PV rises above this value.
DO Low Low	DO PV drops below this value.
DO Low	DO PV drops below this value.
DO High	DO PV rises above this value.
DO High High	DO PV rises above this value.
pH Low Low	pH PV drops below this value.
pH Low	pH PV drops below this value.
pH High	pH PV rises above this value.
pH High High	pH PV rises above this value.
Pressure Low Low	Pressure PV drops below this value.
Pressure Low	Pressure PV drops below this value.
Pressure High	Pressure PV rises above this value.
Pressure High High	Pressure PV rises above this value.
Level Low Low	Level PV drops below this value.
Level Low	Level PV drops below this value.
Level High	Level PV rises above this value.
Level High High	Level PV rises above this value.
Filter Oven Low Low	Filter oven temperature PV drops below this value.
Filter Oven Low	Filter oven temperature PV drops below this value.
Filter Oven High	Filter oven temperature PV rises above this value.
Filter Oven High High	Filter oven temperature PV rises above this value.
Main Gas Low Low	Main gas flow drops below this value.
Main Gas Low	Main gas flow drops below this value.
Main Gas High	Main gas flow rises above this value.
Main Gas High High	Main gas flow rises above this value.

Alarm Name	Alarm is Triggered When:
Leak Detected	The leak sensor detects a leak.
Sequence Resumed	The RIO lost power while a recipe was running, and attempted to restart the recipe when it booted up.
Temperature Sensor Mismatch	The temperature sensors register measurements that differ by more than the Temperature “Mismatch Thresh (C)” setting.
DO Sensor Mismatch	(N/A on PBS-15/80) The DO sensors register measurements that differ by more than the DO “Mismatch Thresh (DO%)” setting.
pH Sensor Mismatch	(N/A on PBS-15/80) The pH sensors register measurements that differ by more than the pH “Mismatch Thresh” setting.
Air Source Pressure Error	The voltage corresponding to the flow rate being delivered by the Air MFC differs from the voltage corresponding to the flow rate being requested of the Air MFC by the Gas Data “Mismatch Thresh (V)” setting. Usually caused by a tank being empty, but could also be from the source pressure being too high.
CO2 Source Pressure Error	The voltage corresponding to the flow rate being delivered by the CO ₂ MFC differs from the voltage corresponding to the flow rate being requested of the CO ₂ MFC by the Gas Data “Mismatch Thresh (V)” setting. Usually caused by a tank being empty, but could also be from the source pressure being too high.
N2 Source Pressure Error	The voltage corresponding to the flow rate being delivered by the N ₂ MFC differs from the voltage corresponding to the flow rate being requested of the N ₂ MFC by the Gas Data “Mismatch Thresh (V)” setting. Usually caused by a tank being empty, but could also be from the source pressure being too high.
O2 Source Pressure Error	The voltage corresponding to the flow rate being delivered by the O ₂ MFC differs from the voltage corresponding to the flow rate being requested of the O ₂ MFC by the Gas Data “Mismatch Thresh (V)” setting. Usually caused by a tank being empty, but could also be from the source pressure being too high.
Agitation Sensor Failure	The agitation motor is being powered but agitation PV = 0 RPM.
Temp Sensor A Failure (range)	Temperature sensor A registers a measurement above the Temperature “Valid High (C)” or below the Temperature “Valid Low (C)” settings.

Alarm Name	Alarm is Triggered When:
Temp Sensor B Failure (range)	Temperature sensor B registers a measurement above the Temperature “Valid High (C)” or below the Temperature “Valid Low (C)” settings.
Temp Dual Sensor Failure	Both temperature sensors register range failures.
DO Sensor A Failure (range)	DO sensor A registers a measurement above the DO “Valid High (DO%)” or below the DO “Valid Low (DO%)” settings.
DO Sensor B Failure (range)	(N/A on PBS-15/80) DO sensor B registers a measurement above the DO “Valid High (DO%)” or below the DO “Valid Low (DO%)” settings.
DO Dual Sensor Failure	(N/A on PBS-15/80) Both DO sensors register range failures.
pH Sensor A Failure (range)	pH sensor A registers a measurement above the pH “Valid High (pH)” or below the pH “Valid Low (pH)” settings.
pH Sensor B Failure (range)	(N/A on PBS-15/80) pH sensor B registers a measurement above the pH “Valid High (pH)” or below the pH “Valid Low (pH)” settings.
pH Sensor A Failure (rate)	pH sensor A registers a change in measurements greater than or equal to the pH “Rate Fail Delta PV” value over the pH “Rate Fail Delta Time (s)” time period.
pH Sensor B Failure (rate)	(N/A on PBS-15/80) pH sensor B registers a change in measurements greater than or equal to the pH “Rate Fail Delta PV” value over the pH “Rate Fail Delta Time (s)” time period.
pH Dual Sensor Failure	(N/A on PBS-15/80) Both pH sensors register rate failures or range failures.
Pressure Sensor Disconnected	The absolute value of the raw voltage associated with the pressure PV is greater than or equal to the Pressure “Disconnected Pressure (V)” setting. Also triggered when the Pressure “Reusable Sensor (0 or 1)” setting is 1 (default for PBS-15/80) and the software detects that the pressure sensing line is disconnected.
Comb Plate Popped	The bag has pressurized enough to lift the comb plate.
Dirty Startup	RIO was restarted using a method other than through the Desktop UI desktop (usually just unplugging the bioreactor), and there was a problem recovering the last user-selected modes, set points etc. If this alarm was triggered, generate an errors report spanning the time this alarm was generated for more detailed information.

Alarm Name	Alarm is Triggered When:
Clean Startup	RIO was restarted through the Desktop UI.
Resume	RIO was restarted using a method other than through the Desktop UI (usually just unplugging the bioreactor), but the last user-selected modes, set points etc. were recovered with no problems.
RT Mem Fragmented*	The largest contiguous block (LCB) of memory on the RIO computer is less than the System “LCB Mem Limit (KB)”.
RT Mem Nearly Full	The available memory on the RIO computer is less than the System “Available Mem Limit (KB)”.
NI 9205 Error*	Analog Input errors reading MFCs, DO, and pH.
NI 9425/Onboard Error	Digital Input errors reading leak sensor, pressure sensor connected, Door Pressure sensor (N/A on PBS-15/80), fuses, and RPM sensor. Digital Output errors writing to motor brake, media pump, and RTOS Run Status light.
NI 9219 Error	Error reading 9219 board (analog inputs for pressure sensor, load cell (N/A on PBS-15/80), and temperature sensors).
NI 9476 Error	Digital Output errors writing to temperature and filter oven heaters, door unlock, buzzer, sample pump, media pump, LED, addition pump A, addition pump B, and PBS 3 MAG agitation motor.
NI 9263 Error	Analog Output errors writing to pumps with RPM input, and to agitation motors other than for the PBS-3.
12 Vdc Atom Fuse*	This fuse needs to be replaced.
12 Vdc Mezz Fuse*	This fuse needs to be replaced.
12 Vdc Mntr Fuse*	This fuse needs to be replaced.
12 Vdc User1 Fuse*	This fuse needs to be replaced.
12 Vdc User2 Fuse	This fuse needs to be replaced.
12 Vdc User3 Fuse	This fuse needs to be replaced.
24 Vdc Fill Pump Fuse	This fuse needs to be replaced.
24 Vdc Ind DO Fuse*	This fuse needs to be replaced.
24 Vdc Main Fuse*	This fuse needs to be replaced.
24 Vdc Mezz Fuse*	This fuse needs to be replaced.
24 Vdc MFC Fuse*	This fuse needs to be replaced.
24 Vdc sbRIO Fuse*	This fuse needs to be replaced.
24 Vdc User1 Fuse*	This fuse needs to be replaced.
24 Vdc User2 Fuse	This fuse needs to be replaced.

Alarm Name	Alarm is Triggered When:
24 Vdc User3 Fuse	This fuse needs to be replaced.
12 Vdc Supply Fuse [†]	This fuse needs to be replaced.
24 Vdc Supply Fuse [†]	This fuse needs to be replaced.
Pump Supply Fuse [†]	This fuse needs to be replaced.
24 Vdc Ctrl Main Fuse [†]	This fuse needs to be replaced.
Unknown Alarm	This is a placeholder alarm, and should never be generated.

* These alarms are only applicable to bioreactors with sbRIO model 9641 or 9642 (as visible in the Desktop UI About tab). If these alarms are not applicable to your bioreactor, they will still appear in the Alarms Editor, but they will not be triggered.

† These alarms are only applicable to bioreactors with sbRIO model 9603 (as visible in the Desktop UI About tab). If these alarms are not applicable to your bioreactor, they will still appear in the Alarms Editor, but they will not be triggered.

Default Alarms Configurations

The PBS-15/80 comes with two default Alarms.alm files on the HMI. PBS Biotech Technical Support recommends loading the Alarms Off.alm file when you are not running a process, and before storing. It is configured to not notify about the alarms which would otherwise be triggered. PBS Biotech Technical Support recommends loading the Alarms On.alm file during a run. For more information, see “Configuring Alarm Settings” on page 69.

NOTICE The email setting is independent of the chosen alarm file. However, if an alarm is not configured to be Notify, the PBS-15/80 will not send an email alert for that alarm.

Alarm Name	Alarms Off		Alarms On		Email
	Notify	Audible	Notify	Audible	
Agitation Low Low			✓	✓	✓
Agitation Low			✓		
Agitation High			✓		
Agitation High High			✓	✓	✓
Temperature Low Low			✓	✓	✓
Temperature Low			✓		
Temperature High	✓		✓		
Temperature High High	✓		✓	✓	✓
DO Low Low			✓	✓	✓
DO Low			✓		
DO High			✓		
DO High High			✓	✓	✓
pH Low Low			✓	✓	✓
pH Low			✓		
pH High			✓		
pH High High			✓	✓	✓
Pressure Low Low			✓	✓	✓
Pressure Low			✓		
Pressure High			✓		
Pressure High High			✓	✓	✓
Level Low Low			✓	✓	✓

Appendix 3 - Default Alarms Configurations

Alarm Name	Alarms Off		Alarms On		Email
	Notify	Audible	Notify	Audible	
Level Low			✓		
Level High			✓		
Level High High			✓	✓	✓
Filter Oven Low Low			✓	✓	✓
Filter Oven Low			✓		
Filter Oven High	✓		✓		
Filter Oven High High	✓		✓	✓	
Main Gas Low Low			✓	✓	✓
Main Gas Low			✓		
Main Gas High	✓		✓		
Main Gas High High	✓		✓	✓	✓
Leak Detected	✓	✓	✓	✓	✓
Sequence Resumed	✓		✓		✓
Temperature Sensor Mismatch			✓	✓	✓
DO Sensor Mismatch					
pH Sensor Mismatch					
Air Source Pressure Error	✓		✓	✓	✓
CO2 Source Pressure Error	✓		✓	✓	✓
N2 Source Pressure Error	✓		✓	✓	✓
O2 Source Pressure Error	✓		✓	✓	✓
Agitation Sensor Failure	✓		✓	✓	✓
Temp Sensor A Failure (range)	✓		✓	✓	✓
Temp Sensor B Failure (range)	✓		✓	✓	✓
Temp Dual Sensor Failure	✓		✓	✓	✓
DO Sensor A Failure (range)			✓	✓	✓
DO Sensor B Failure (range)					

Appendix 3 - Default Alarms Configurations

Alarm Name	Alarms Off		Alarms On		Email
	Notify	Audible	Notify	Audible	
DO Dual Sensor Failure					
pH Sensor A Failure (range)			✓	✓	✓
pH Sensor B Failure (range)					
pH Sensor A Failure (rate)			✓	✓	✓
pH Sensor B Failure (rate)					
pH Dual Sensor Failure					
Pressure Sensor Disconnected			✓	✓	✓
Comb Plate Popped	✓		✓		✓
Dirty Startup	✓		✓		
Clean Startup	✓		✓		
Resume	✓		✓		
RT Mem Fragmented*	✓		✓		✓
RT Mem Nearly Full	✓		✓		✓
NI 9205 Error*	✓		✓		✓
NI 9425/Onboard Error	✓		✓		✓
NI 9219 Error	✓		✓		✓
NI 9476 Error	✓		✓		✓
NI 9263 Error	✓		✓	✓	✓
12 Vdc Atom Fuse*	✓		✓		
12 Vdc Mezz Fuse*	✓		✓		
12 Vdc Mntr Fuse*	✓		✓		
12 Vdc User1 Fuse*	✓		✓		
12 Vdc User2 Fuse	✓		✓		
12 Vdc User3 Fuse	✓		✓		
24 Vdc Fill Pump Fuse	✓		✓		
24 Vdc Ind DO Fuse*	✓		✓		
24 Vdc Main Fuse*	✓		✓		

Appendix 3 - Default Alarms Configurations

Alarm Name	Alarms Off		Alarms On		Email
	Notify	Audible	Notify	Audible	
24 Vdc Mezz Fuse*	✓		✓		
24 Vdc MFC Fuse*	✓		✓		
24 Vdc sbRIO Fuse*	✓		✓		
24 Vdc User1 Fuse*	✓		✓		
24 Vdc User2 Fuse	✓		✓		
24 Vdc User3 Fuse	✓		✓		
12 Vdc Supply Fuse†	✓		✓		
24 Vdc Supply Fuse†	✓		✓		
Pump Supply Fuse†	✓		✓		
24 Vdc Ctrl Main Fuse†	✓		✓		
Unknown Alarm	✓		✓		

* These alarms are only applicable to bioreactors with sbRIO model 9641 or 9642 (as visible in the Desktop UI About tab). If these alarms are not applicable to your bioreactor, they will still appear in the Alarms Editor, but they will not be triggered.

† These alarms are only applicable to bioreactors with sbRIO model 9603 (as visible in the Desktop UI About tab). If these alarms are not applicable to your bioreactor, they will still appear in the Alarms Editor, but they will not be triggered.

Default Logger Configurations and Global Variables Definitions

The PBS-15/80 ships with a default Logger file loaded. For more information, see “Configuring Logger Settings” on page 66.

AGITATION

Variable Name	Default Deadband		Default Record	Source	Definition
	PBS-15	PBS-80			
AgAtLeast1GoodSensor	0.500	0.500		Calc	Signals if the agitation sensor is functioning correctly.
AgAutoMaxStartup(%)	0.001	0.001		System	See Agitation “Auto Max Startup (%)” setting in Appendix 1.
AgControlAlpha	0.001	0.001		System	See Agitation “Alpha” setting in Appendix 1.
AgControlBeta	0.001	0.001		System	See Agitation “Beta” setting in Appendix 1.
AgControlGamma	0.001	0.001		System	See Agitation “Gamma” setting in Appendix 1.
AgControlLinearity	0.001	0.001		System	See Agitation “Linearity” setting in Appendix 1.
AgGasAutoMaxStartup (LPM)	0.001	0.001		System	(N/A on PBS-15/80) Corresponds to a System Variable only applicable to PBS AirDrive Bioreactors.
AgLookupFactor (LPM/RPM)	0.001	0.001		System	(N/A on PBS-15/80) Corresponds to a System Variable only applicable to PBS AirDrive Bioreactors.
AgLookupModeTimeout (ms)	0.001	0.001		System	See Agitation “Lookup Mode Timeout (s)” setting in Appendix 1.
AgMainGasActualRequest (LPM)	0.400	2.000		Calc	(N/A on PBS-15/80) For AirDrive Bioreactors, the flow rate requested of the main gas MFCs.

AGITATION (continued)

Variable Name	Default Deadband		Default Record	Source	Definition
	PBS-15	PBS-80			
AgMainGasControl.DTime (min)	0.001	0.001		System	(N/A on PBS-15/80) Corresponds to a System Variable only applicable to PBS AirDrive Bioreactors.
AgMainGasControl.ITime (min)	0.001	0.001		System	(N/A on PBS-15/80) Corresponds to a System Variable only applicable to PBS AirDrive Bioreactors.
AgMainGasControl.PGain (LPM/RPM)	0.001	0.001		System	(N/A on PBS-15/80) Corresponds to a System Variable only applicable to PBS AirDrive Bioreactors.
AgMainGasRangeAuto (LPM).Max	0.001	0.001		System	(N/A on PBS-15/80) Corresponds to a System Variable only applicable to PBS AirDrive Bioreactors.
AgMainGasRangeAuto (LPM).Min	0.001	0.001		System	(N/A on PBS-15/80) Corresponds to a System Variable only applicable to PBS AirDrive Bioreactors.
AgMainGasRangeManMax (LPM)	0.001	0.001		System	(N/A on PBS-15/80) Corresponds to a System Variable only applicable to PBS AirDrive Bioreactors.
AgMainGasUser(LPM)	0.400	2.000		User	(N/A on PBS-15/80) For PBS AirDrive Bioreactors, the last user-defined main gas output used when agitation was in Manual mode.
AgMin(RPM)	0.001	0.001		System	See Agitation “Minimum (RPM)” setting in Appendix 1.

AGITATION (continued)

Variable Name	Default Deadband		Default Record	Source	Definition
	PBS-15	PBS-80			
AgMinGasSum(V)	0.001	0.001		System	(N/A on PBS-15/80) Corresponds to a System Variable only applicable to PBS AirDrive Bioreactors.
AgMinPower(%)	0.001	0.001		System	See Safety “Min Ag Power (%)” setting in Appendix 1.
AgModeActual	0.500	0.500	✓	Calc	The actual agitation mode: 0) Auto, 1) Manual, 2) Off, 3) Lookup, and 4) Pulse.
AgModeUser	0.500	0.500		User	The user-requested agitation mode: 0) Auto, 1) Manual, and 2) Off.
AgMotorPWM.Duty	0.100	0.100		Calc	Not in use.
AgMotorPWM.OnTime (Cycle)	1.000	1.000		Calc	(N/A on PBS-15/80) For the PBS 3 MAG (SUS), the time that the agitation motor stays on each period, in number of cycles of the hardware writing to the agitation motor. 1 Cycle $\approx 36 \mu s$.
AgMotorPWM.Period (Cycle)	1.000	1.000		Calc	(N/A on PBS-15/80) For the PBS 3 MAG (SUS), the pulse width modulation period for the agitation motor, in number of cycles of the hardware writing to the agitation motor. 1 Cycle $\approx 36 \mu s$.
AgMotorPower(V)	0.100	0.100		Calc	Used by the system to calculate % power to output to the agitation motor.
AgPV(RPM)	0.500	0.500	✓	Calc	The speed of the wheel detected by the software.

AGITATION (continued)

Variable Name	Default Deadband		Default Record	Source	Definition
	PBS-15	PBS-80			
AgPowerActualRequest(%)	2.000	2.000	✓	Calc	The % power being sent to the agitation motor.
AgPowerControl.DTime (min)	0.010	0.010		System	See Agitation “D Time (min)” setting in Appendix 1.
AgPowerControl.ITime (min)	0.010	0.010		System	See Agitation “I Time (min)” setting in Appendix 1.
AgPowerControl.PGain (%/RPM)	0.010	0.010		System	See Agitation “P Gain (%/RPM)” setting in Appendix 1.
AgPowerRangeAuto (%).Max	0.010	0.010		System	See Agitation “Power Auto Max (%)” setting in Appendix 1.
AgPowerRangeAuto (%).Min	0.010	0.010		System	See Agitation “Power Auto Min (%)” setting in Appendix 1.
AgPowerRangeManMax (%)	0.010	0.010		System	See Agitation “Power Manual Max (%)” setting in Appendix 1.
AgPowerUser(%)	0.100	0.100	✓	User	The last user-defined power output used when agitation was in Manual mode.
AgPulseModeTimeout(ms)	1.000	1.000		System	See Agitation “Pulse Mode Timeout (s)” setting in Appendix 1.
AgPwrLookupFactor (%/RPM)	0.001	0.001		System	See Agitation “Lookup Factor (%/RPM)” setting in Appendix 1.
AgRPMLoopTime (ticks/Cycle)	0.500	0.500		Sensor	The length of time, in ticks, of 1 cycle of the hardware reading the agitation sensor. 1 tick = 25 ns.

AGITATION (continued)

Variable Name	Default Deadband		Default Record	Source	Definition
	PBS-15	PBS-80			
AgSP(RPM)	0.500	0.500	✓	User	The last agitation set point used when agitation was in Auto mode.
AgWheelCount	1.000	1.000		Sensor	Raw count from input counter.
AgWheelLastPeriod(iter)	1.000	1.000		Sensor	How many iterations since the last completed wheel period. 1 iter \approx 2400 ns.
AgWheelMagnetCount	0.500	0.500		System	See Agitation “Number of Magnets” setting in Appendix 1.
AgWheelSamplesTo Average	0.500	0.500		System	See Agitation “Samples To Average” setting in Appendix 1.
AgWheelSense	0.500	0.500		Sensor	True when the agitation sensor senses a Vertical-Wheel® impeller magnet.
AgWheelTimeSinceLast Mag(Cycle)	1.000	1.000		Sensor	Elapsed time since last magnet pass detected. 1 Cycle \approx 2400 ns.
HarvestDelay(s)	0.001	0.001	✓	System	For PBS Bioreactors size 15 and higher, when aligning the wheel for harvest, this is the number of seconds to continue turning the wheel after the agitation sensor senses a magnet pass.
HarvestMode	0.500	0.500	✓	User	For PBS Bioreactors size 15 and higher, 0) not in Harvest mode, 1) ramping down agitation, 2) aligning the wheel, or 3) harvesting. For other models, this variable should not be modified via recipe.

AGITATION (continued)

Variable Name	Default Deadband		Default Record	Source	Definition
	PBS-15	PBS-80			
HarvestTimeout	0.500	0.500	✓	Calc	For PBS Bioreactors size 15 and higher, true if while aligning the wheel for harvest, the sensor has not detected a magnet pass in 20 seconds for PBS-15, or 40 seconds for PBS-80.

ALARM

Variable Name	Default Deadband		Default Record	Source	Definition
	PBS-15	PBS-80			
AlarmBuzzerOnTime (Cycle)	10.000	10.000		Calc	The time that the buzzer stays on each period, in number of cycles of the hardware writing to the buzzer. 1 Cycle \approx 36 μ s. When the buzzer should sound, this is half the value of the period.
AlarmBuzzerPeriod(Cycle)	10.000	10.000		System	See Safety “Buzzer Period (ms)” setting in Appendix 1.
AlarmBuzzerUser	0.500	0.500		User	True when the user wants to test the buzzer.
AlarmFuseStatus	0.500	0.500		Sensor	Status of the fuses – when the number is above zero it means at least 1 fuse is blown.
AlarmLeak	0.500	0.500		Sensor	True when the software detects a leak.
AlarmSnoozeTime(ms)	1.000	1.000		System	See System “Alarm Snooze Time (s)” setting in Appendix 1.
Alm_CombPlate	0.500	0.500		Sensor	For PBS Vertical-Wheel [®] Bioreactors with a comb plate, true when the comb plate has popped up.

CALIBRATION

Variable Name	Default Deadband		Default Record	Source	Definition
	PBS-15	PBS-80			
CalDOA.Offset(%)	0.010	0.010		System	The offset of the raw voltage to DO sensor A PV conversion.
CalDOA.Slope	0.010	0.010		System	The slope of the raw voltage to DO sensor A PV conversion.
CalDOB.Offset(%)	0.010	0.010		System	(N/A on PBS-15/80) For PBS Vertical-Wheel® Bioreactors with duplicate DO sensors, the offset of the raw value to DO sensor B PV conversion.
CalDOB.Slope	0.010	0.010		System	(N/A on PBS-15/80) For PBS Vertical-Wheel® Bioreactors with duplicate DO sensors, the slope of the raw value to DO sensor B PV conversion.
CalFilterOvenTemp.Offset (C)	0.010	0.010		System	The offset for the raw resistance to filter oven temperature PV conversion.
CalFilterOvenTemp.Slope	0.010	0.010		System	The slope of the raw resistance to filter oven temperature PV conversion.
CalLevel.b	0.010	0.010		System	The offset of the raw voltage to level PV conversion.
CalLevel.m	0.010	0.010		System	The slope of the raw voltage to level PV conversion.
CalLimitsLevel.CallLevel InterceptMax(psi)	0.001	0.001		System	See Level "CallLevel InterceptMax(psi)" setting in Appendix 1.

CALIBRATION (continued)

Variable Name	Default Deadband		Default Record	Source	Definition
	PBS-15	PBS-80			
CalLimitsLevel.CallLevel InterceptMin(psi)	0.001	0.001		System	See Level “CallLevel InterceptMin(psi)” setting in Appendix 1.
CalLimitsLevel.CallLevel SlopeMax(psi/V)	0.001	0.001		System	See Level “CallLevel SlopeMax(psi/V)” setting in Appendix 1.
CalLimitsLevel.CallLevel SlopeMin(psi/V)	0.001	0.001		System	See Level “CallLevel SlopeMin(psi/V)” setting in Appendix 1.
CalLimitsPressure.Call PressureInterceptMax(psi)	0.001	0.001		System	See Pressure “Cal PressureInterceptMax (psi)” setting in Appendix 1.
CalLimitsPressure.Call PressureInterceptMin(psi)	0.001	0.001		System	See Pressure “Cal PressureInterceptMin (psi)” setting in Appendix 1.
CalLimitsPressure.Call PressureSlopeMax(psi/V)	0.001	0.001		System	See Pressure “Cal PressureSlopeMax (psi/V)” setting in Appendix 1.
CalLimitsPressure.Call PressureSlopeMin(psi/V)	0.001	0.001		System	See Pressure “Cal PressureSlopeMin (psi/V)” setting in Appendix 1.
CalMFCAir.b(LPM)	0.001	0.001		System	The offset of the raw voltage to Air flow (LPM) output conversion.
CalMFCAir.m(LPM/V)	0.001	0.001		System	The slope of the raw voltage to Air flow (LPM) output conversion.
CalMFCCO2.b(LPM)	0.001	0.001		System	The offset of the raw voltage to CO ₂ flow (LPM) output conversion.
CalMFCCO2.m(LPM/V)	0.001	0.001		System	The slope of the raw voltage to CO ₂ flow (LPM) output conversion.

CALIBRATION (continued)

Variable Name	Default Deadband		Default Record	Source	Definition
	PBS-15	PBS-80			
CalMFCN2.b(LPM)	0.001	0.001		System	The offset of the raw voltage to N ₂ flow (LPM) output conversion.
CalMFCN2.m(LPM/V)	0.001	0.001		System	The slope of the raw voltage to N ₂ flow (LPM) output conversion.
CalMFCO2.b(LPM)	0.001	0.001		System	The offset of the raw voltage to O ₂ flow (LPM) output conversion.
CalMFCO2.m(LPM/V)	0.001	0.001		System	The slope of the raw voltage to O ₂ flow (LPM) output conversion.
CalPressure.Offset(psi)	0.010	0.010		System	For PBS Vertical-Wheel [®] Bioreactors with a pressure sensor, the offset of the raw voltage to pressure PV conversion.
CalPressure.Slope	0.010	0.010		System	For PBS Vertical-Wheel [®] Bioreactors with a pressure sensor, the slope of the raw voltage to pressure PV conversion.
CalTempA.Offset(C)	0.010	0.010		System	The offset of the raw resistance to temperature sensor A PV conversion.
CalTempA.Slope	0.010	0.010		System	The slope of the raw resistance to temperature sensor A PV conversion.
CalTempB.Offset(C)	0.010	0.010		System	For PBS Vertical-Wheel [®] Bioreactors with duplicate temperature sensors, the offset of the raw resistance to temperature sensor B PV conversion.

CALIBRATION (continued)

Variable Name	Default Deadband		Default Record	Source	Definition
	PBS-15	PBS-80			
CalTempB.Slope	0.010	0.010		System	For PBS Vertical-Wheel® Bioreactors with duplicate temperature sensors, the slope of the raw resistance to temperature sensor B PV conversion.
CalpHA.Offset(%)	0.010	0.010		System	The offset of the raw voltage to pH sensor A PV conversion.
CalpHA.Slope	0.010	0.010		System	The slope of the raw voltage to pH sensor A PV conversion.
CalpHA.Temp(C)	0.010	0.010		System	The temperature at which pH sensor A was calibrated.
CalpHB.Offset(%)	0.010	0.010		System	(N/A on PBS-15/80) For PBS Vertical-Wheel® Bioreactors with duplicate pH sensors, the offset of the raw voltage to pH sensor B PV conversion.
CalpHB.Slope	0.100	0.100		System	(N/A on PBS-15/80) For PBS Vertical-Wheel® Bioreactors with duplicate pH sensors, the slope of the raw voltage to pH sensor B PV conversion.
CalpHB.Temp(C)	0.100	0.100		System	(N/A on PBS-15/80) For PBS Vertical-Wheel® Bioreactors with duplicate reusable pH sensors, the temperature at which pH sensor B was calibrated.

DO

Variable Name	Default Deadband		Default Record	Source	Definition
	PBS-15	PBS-80			
DOA(%)	2.000	2.000		Calc	The PV reported by DO sensor A.
DOAIsPrimaryActual	0.500	0.500		Calc	True when the software reports DO PV as what DO sensor A measures.
DOARaw(%)	0.100	0.100		Sensor	The raw voltage DO sensor A reports.
DOAIsActive	0.500	0.500		Calc	True when DO sensor A is not failed.
DOAIsPrimaryUser	0.500	0.500		User	(N/A on PBS-15/80) For PBS Vertical-Wheel® Bioreactors with duplicate DO sensors, true when the user prefers that the software reports DO PV as what DO sensor A measures.
DOAtLeast1GoodSensor	0.500	0.500		Calc	Indicates if at least 1 DO sensor has not failed.
DOB(%)	2.000	2.000		Calc	(N/A on PBS-15/80) For PBS Vertical-Wheel® Bioreactors with duplicate DO sensors, the PV reported by DO sensor B.
DOBRaw(%)	0.100	0.100		Sensor	(N/A on PBS-15/80) For PBS Vertical-Wheel® Bioreactors with duplicate DO sensors, the raw voltage DO sensor B reports.
DOBIsActive	0.500	0.500		Calc	(N/A on PBS-15/80) For PBS Vertical-Wheel® Bioreactors with duplicate DO sensors, true when DO sensor B has not failed.

DO (continued)

Variable Name	Default Deadband		Default Record	Source	Definition
	PBS-15	PBS-80			
DODeadband(%)	0.001	0.001	✓	System	See DO “Deadband (DO%)” setting in Appendix 1.
DOHardware	0.500	0.500		System	A configuration set at the factory to tell the software which DO sensors the hardware supports. This variable should not be modified via recipe.
DOInRange.A	0.500	0.500		Calc	True when DO sensor A is in valid range.
DOInRange.B	0.500	0.500		Calc	(N/A on PBS-15/80) For PBS Vertical-Wheel® Bioreactors with duplicate DO sensors, true when DO sensor B is in valid range.
DOMismatchThresh(%)	0.001	0.001		System	See DO “Mismatch Thresh (DO%)” setting in Appendix 1.
DOModeActual	0.500	0.500	✓	Calc	The actual DO mode: 0) Auto, 1) Manual, 2) Off, and 3) Broken Sensor.
DOModeUser	0.500	0.500		User	The user-requested DO mode: 0) Auto, 1) Manual, and 2) Off.
DON2Control.DTime(min)	0.001	0.001		System	See DO “N2 D Time (min)” setting in Appendix 1.
DON2Control.ITime(min)	0.001	0.001		System	See DO “N2 I Time (min)” setting in Appendix 1.
DON2Control.PGain(%/%)	0.001	0.001		System	See DO “N2 P Gain (%/DO%)” setting in Appendix 1.
DON2ControlAlpha	0.001	0.001		System	See DO “N2 Alpha” setting in Appendix 1.

DO (continued)

Variable Name	Default Deadband		Default Record	Source	Definition
	PBS-15	PBS-80			
DON2ControlBeta	0.001	0.001		System	See DO “N2 Beta” setting in Appendix 1.
DON2ControlGamma	0.001	0.001		System	See DO “N2 Gamma” setting in Appendix 1.
DON2ControlLinearity	0.001	0.001		System	See DO “N2 Linearity” setting in Appendix 1.
DON2FlowActualRequest (%)	2.000	2.000	✓	Calc	The N ₂ flow output the software actually requests from the N ₂ MFC, in percent of main gas flow. It limits the N ₂ flow the DO controller requests by taking the maximum N ₂ MFC flow, the CO ₂ flow request, and the O ₂ flow request into account.
DON2FlowController Request(%)	2.000	2.000		Calc	The N ₂ flow output requested by the DO controller, in percent of main gas flow.
DON2FlowUser(%)	1.000	1.000	✓	User	The last user-defined N ₂ output used when DO was in Manual mode.
DON2RangeAutoMax(%)	0.001	0.001		System	See DO “N2 Auto Max (%)” setting in Appendix 1.
DON2RangeManMax(%)	0.001	0.001		System	See DO “N2 Manual Max (%)” setting in Appendix 1.
DOO2ControlAir.DTime (min)	0.001	0.001		System	(N/A on PBS-15/80) Corresponds to a System Variable only applicable to PBS AirDrive Bioreactors.

DO (continued)

Variable Name	Default Deadband		Default Record	Source	Definition
	PBS-15	PBS-80			
DOO2ControlAir.ITime (min)	0.001	0.001		System	(N/A on PBS-15/80) Corresponds to a System Variable only applicable to PBS AirDrive Bioreactors.
DOO2ControlAir.PGain (mLPM/%)	0.001	0.001		System	(N/A on PBS-15/80) Corresponds to a System Variable only applicable to PBS AirDrive Bioreactors.
DOO2ControlAlpha	0.001	0.001		System	See DO “O2 Alpha” setting in Appendix 1.
DOO2ControlBeta	0.001	0.001		System	See DO “O2 Beta” setting in Appendix 1.
DOO2ControlGamma	0.001	0.001		System	See DO “O2 Gamma” setting in Appendix 1.
DOO2ControlLinearity	0.001	0.001		System	See DO “O2 Linearity” setting in Appendix 1.
DOO2ControlMag.DTime (min)	0.001	0.001		System	See DO “O2 D Time (min)” setting in Appendix 1.
DOO2ControlMag.ITime (min)	0.001	0.001		System	See DO “O2 I Time (min)” setting in Appendix 1.
DOO2ControlMag.PGain (%/%)	0.001	0.001		System	See DO “O2 P Gain (%/DO%)” setting in Appendix 1.
DOO2FlowController Request(%)	2.000	2.000		Calc	The O ₂ flow output requested by the DO controller, in percent of main gas flow.
DOO2FlowController Request(mLPM)	5.000	100.000		Calc	(N/A on PBS-15/80) For PBS AirDrive Bioreactors, the O ₂ flow output requested by the DO controller, in mL/min.

DO (continued)

Variable Name	Default Deadband		Default Record	Source	Definition
	PBS-15	PBS-80			
DOO2FlowController RequestLimited(%)	2.000	2.000	✓	Calc	The O ₂ flow output the software actually requests from the O ₂ MFC, in percent of main gas flow. It limits the O ₂ flow the DO controller requests by taking the maximum O ₂ MFC flow, the Gas Data “O2 Min Volume (L)” setting, and the requested CO ₂ flow into account.
DOO2FlowController RequestLimited(mLPM)	5.000	100.000		Calc	The O ₂ flow output the software actually requests from the O ₂ MFC, in mL/min. It limits the O ₂ flow the DO controller requests by taking the maximum O ₂ MFC flow, the Gas Data “O2 Min Volume (L)” setting, and the requested CO ₂ flow into account.
DOO2FlowUser(%)	0.100	0.100	✓	User	The last user-defined O ₂ output used when DO was in Manual mode.
DOO2FlowUser(mLPM)	1.000	1.000		User	(N/A on PBS-15/80) For PBS AirDrive Bioreactors, the last user-defined O ₂ output used when DO was in Manual mode.
DOO2RangeAutoMax(%)	1.000	1.000		System	See DO “O2 Auto Max (%)” setting in Appendix 1.
DOO2RangeAutoMax (mLPM)	0.001	0.001		System	(N/A on PBS-15/80) Corresponds to a System Variable only applicable to PBS AirDrive Bioreactors.

DO (continued)

Variable Name	Default Deadband		Default Record	Source	Definition
	PBS-15	PBS-80			
DOO2RangeManMax(%)	0.001	0.001		System	See DO “O2 Manual Max (%)” setting in Appendix 1.
DOO2RangeManMax (mLPM)	0.001	0.001		System	(N/A on PBS-15/80) Corresponds to a System Variable only applicable to PBS AirDrive Bioreactors.
DOPV(%)	2.000	2.000	✓	Calc	The DO value detected by the software.
DOSP(%)	1.000	1.000	✓	User	The last DO set point used when DO was in Auto mode.
DOUserConfig	0.500	0.500		User	(N/A on PBS-15/80) For PBS Vertical-Wheel® Bioreactors with duplicate DO sensors, a user configuration to tell the software which DO sensors the user has installed.
DOValidMax(%)	0.001	0.001		System	See DO “Valid High (DO%)” setting in Appendix 1.
DOValidMin(%)	0.001	0.001		System	See DO “Valid Low (DO%)” setting in Appendix 1.

DOOR

Variable Name	Default Deadband		Default Record	Source	Definition
	PBS-15	PBS-80			
DoorLockActual	0.500	0.500		Calc	For PBS Vertical-Wheel® Bioreactors with a door, indicates if the user is attempting to unlock the door, and the door is not interlocked.

DOOR (continued)

Variable Name	Default Deadband		Default Record	Source	Definition
	PBS-15	PBS-80			
DoorPressureSafe	0.500	0.500		Sensor	(N/A on PBS-15/80) For PBS Vertical-Wheel® Bioreactors with a door pressure sensor, indicates if the door pressure sensor reports a safe value.
DoorPressureSensor	0.500	0.500		System	See Safety “Door PressureSensor (0 or 1)” setting in Appendix 1.
DoorUnlockUser	0.500	0.500		User	For PBS Vertical-Wheel® Bioreactors with a door, the user sets this to true to request the door to be unlocked.
ReusablePressure Connected	0.500	0.500	✓	Sensor	For PBS Vertical-Wheel® Bioreactors with a reusable pressure sensor, indicates if the reusable pressure sensor is connected.

FILTER OVEN

Variable Name	Default Deadband		Default Record	Source	Definition
	PBS-15	PBS-80			
FilterOvenDutyActual(%)	25.000	25.000	✓	Calc	The heater duty of the filter oven.
FilterOvenDuty Control.DTime(min)	0.001	0.001		System	See Filter Oven “D Time (min)” setting in Appendix 1.
FilterOvenDuty Control.Gain(%/C)	0.001	0.001		System	See Filter Oven “P Gain (%/C)” setting in Appendix 1.
FilterOvenDuty Control.ITime(min)	0.001	0.001		System	See Filter Oven “I Time (min)” setting in Appendix 1.
FilterOvenDutyControl Alpha	0.001	0.001		System	See Filter Oven “Alpha” setting in Appendix 1.

FILTER OVEN (continued)

Variable Name	Default Deadband		Default Record	Source	Definition
	PBS-15	PBS-80			
FilterOvenDutyControlBeta	0.001	0.001		System	See Filter Oven “Beta” setting in Appendix 1.
FilterOvenDutyControlGamma	0.001	0.001		System	See Filter Oven “Gamma” setting in Appendix 1.
FilterOvenDutyControlLinearity	0.001	0.001		System	See Filter Oven “Linearity” setting in Appendix 1.
FilterOvenDutyRangeAutoMax(%)	0.001	0.001		System	See Filter Oven “Heat Auto Max (%)” setting in Appendix 1.
FilterOvenDutyRangeManualMax(%)	0.001	0.001		System	See Filter Oven “Heat Manual Max (%)” setting in Appendix 1.
FilterOvenDutyUser(%)	1.000	1.000	✓	User	The last user-defined heater duty used when filter oven was in Manual mode.
FilterOvenModeActual	0.500	0.500	✓	Calc	The actual filter oven mode: 0) Auto, 1) Manual, 2) Off, and 3) Broken Sensor.
FilterOvenModeUser	0.500	0.500		User	The user-requested filter oven mode: 0) Auto, 1) Manual, and 2) Off.
FilterOvenOnTime(Cycle)	10.000	10.000		Calc	The time that the filter oven stays on each period, in number of cycles of the hardware writing to the filter oven heater. 1 Cycle \approx 36 μ s.
FilterOvenPV(C)	5.000	5.000	✓	Calc	The temperature of the filter oven detected by the software.

FILTER OVEN (continued)

Variable Name	Default Deadband		Default Record	Source	Definition
	PBS-15	PBS-80			
FilterOvenPeriod(Cycle)	10.000	10.000		Calc	The pulse width modulation period for the filter oven heater, in number of cycles of the hardware writing to the main heater. Corresponds to 1 second. 1 Cycle \approx 36 μ s.
FilterOvenRaw(C)	5.000	5.000		Sensor	The raw resistance the filter oven sensor reports.
FilterOvenSP(C)	1.000	1.000	✓	User	The last filter oven set point used when filter oven was in Auto mode.
FilterOvenSensorActive	0.500	0.500		Calc	True when the filter oven temperature sensor has not failed.

GASES

Variable Name	Default Deadband		Default Record	Source	Definition
	PBS-15	PBS-80			
MFCAirFlowFeedback (LPM)	0.100	0.500	✓	Calc	The voltage feedback from the Air MFC converted to a flow rate with its slope and offset, representing the actual flow out of the Air MFC.
MFCAirMeasRaw(V)	0.100	0.100		Sensor	The raw voltage the Air MFC reports.
MFCAirMin(LPM)	0.001	0.001		System	See Gas Data “Air Min (LPM)” setting in Appendix 1.
MFCAirOff(V)	0.001	0.001		System	See Gas Data “Air Off (V)” setting in Appendix 1.

GASES (continued)

Variable Name	Default Deadband		Default Record	Source	Definition
	PBS-15	PBS-80			
MFCAirOutRaw(V).AO(V)	0.100	0.100		Calc	The voltage to request from the Air MFC when the pulse width modulation determines the Air MFC should be pulsing. This allows the MFC to deliver a flow which is effectively lower than its minimum flow rate.
MFCAirOutRaw(V).On(iter)	0.100	0.100		Calc	The time that the Air MFC stays on each period, in number of iterations of the hardware writing to the MFCs. 1 iter \approx 8850 ns.
MFCAirOutRaw(V).Period (iter)	0.100	0.100		Calc	The pulse width modulation period for the Air MFC, in number of iterations of the hardware writing to the MFCs. 1 iter \approx 8850 ns.
MFCCO2FlowFeedback (LPM)	0.060	0.400	✓	Calc	The voltage feedback from the CO ₂ MFC converted to a flow rate with its slope and offset, representing the actual flow out of the CO ₂ MFC.
MFCCO2MeasRaw(V)	0.100	0.100		Sensor	The raw voltage the CO ₂ MFC reports.
MFCCO2Min(LPM)	0.001	0.001		System	See Gas Data “CO ₂ Min (LPM)” setting in Appendix 1.
MFCCO2Off(V)	0.001	0.001		System	See Gas Data “CO ₂ Off (V)” setting in Appendix 1.

GASES (continued)

Variable Name	Default Deadband		Default Record	Source	Definition
	PBS-15	PBS-80			
MFCCO2OutRaw.AO(V)	0.100	0.100		Calc	The voltage to request from the CO ₂ MFC when the pulse width modulation determines the CO ₂ MFC should be pulsing. This allows the MFC to deliver a flow which is effectively lower than its minimum flow rate.
MFCCO2OutRaw.On(iter)	0.100	0.100		Calc	The time that the CO ₂ MFC stays on each period, in number of iterations of the hardware writing to the MFCs. 1 iter ≈ 8850 ns.
MFCCO2OutRaw.Period (iter)	0.100	0.100		Calc	The pulse width modulation period for the CO ₂ MFC, in number of iterations of the hardware writing to the MFCs. 1 iter ≈ 8850 ns.
MFCLoopTime(ticks/Cycle)	1.000	1.000		Sensor	The length of time, in ticks, of 1 cycle of the hardware writing to the MFCs and NI 9263. 1 tick = 25 ns.
MFCMaxPeriod(s)	0.001	0.001		System	See Gas Data “PWM Max Period (s)” setting in Appendix 1.
MFCMismatchThresh(V)	0.001	0.001		System	See Gas Data “Mismatch Thresh (V)” setting in Appendix 1.
MFCN2FlowFeedback (LPM)	0.100	0.500	✓	Calc	The voltage feedback from the N ₂ MFC converted to a flow rate with its slope and offset, representing the actual flow out of the N ₂ MFC.

GASES (continued)

Variable Name	Default Deadband		Default Record	Source	Definition
	PBS-15	PBS-80			
MFCN2MeasRaw(V)	0.100	0.100		Sensor	The raw voltage the N ₂ MFC reports.
MFCN2Min(LPM)	0.001	0.001		System	See Gas Data “N2 Min (LPM)” setting in Appendix 1.
MFCN2Off(V)	0.001	0.001		System	See Gas Data “N2 Off (V)” setting in Appendix 1.
MFCN2OutRaw(V).AO(V)	0.100	0.100		Calc	The voltage to request from the N ₂ MFC when the pulse width modulation determines the N ₂ MFC should be pulsing. This allows the MFC to deliver a flow which is effectively lower than its minimum flow rate.
MFCN2OutRaw(V).On(iter)	0.100	0.100		Calc	The time that the N ₂ MFC stays on each period, in number of iterations of the hardware writing to the MFCs. 1 iter ≈ 8850 ns.
MFCN2OutRaw(V).Period (iter)	0.100	0.100		Calc	The pulse width modulation period for the N ₂ MFC, in number of iterations of the hardware writing to the MFCs. 1 iter ≈ 8850 ns.
MFCO2FlowFeedback (LPM)	0.025	0.500	✓	Calc	The voltage feedback from the O ₂ MFC converted to a flow rate with its slope and offset, representing the actual flow out of the O ₂ MFC.
MFCO2MeasRaw(V)	0.100	0.100		Sensor	The raw voltage the O ₂ MFC reports.

GASES (continued)

Variable Name	Default Deadband		Default Record	Source	Definition
	PBS-15	PBS-80			
MFCO2Min(LPM)	0.001	0.001		System	See Gas Data “O2 Min (LPM)” setting in Appendix 1.
MFCO2Off(V)	0.001	0.001		System	See Gas Data “O2 Off (V)” setting in Appendix 1.
MFCO2OutRaw.AO(V)	0.100	0.100		Calc	The voltage to request from the O ₂ MFC when the pulse width modulation determines the O ₂ MFC should be pulsing. This allows the MFC to deliver a flow which is effectively lower than its minimum flow rate.
MFCO2OutRaw.On(iter)	0.100	0.100		Calc	The time that the O ₂ MFC stays on each period, in number of iterations of the hardware writing to the MFCs. 1 iter ≈ 8850 ns.
MFCO2OutRaw.Period (iter)	0.100	0.100		Calc	The pulse width modulation period for the O ₂ MFC, in number of iterations of the hardware writing to the MFCs. 1 iter ≈ 8850 ns.
MFCOnTime(s)	0.001	0.001		System	See Gas Data “PWM On Time (s)” setting in Appendix 1.
O2 Min Volume (L)	0.001	0.001		System	See Gas Data “O2 Min Volume (L)” setting in Appendix 1.

INTERLOCKS

Variable Name	Default Deadband		Default Record	Source	Definition
	PBS-15	PBS-80			
InterlockAgMotor	0.500	0.500		Calc	For PBS Bioreactors size 15 and higher, this indicates whether the agitation motor will not turn on because it is interlocked.
InterlockAll	0.500	0.500		Calc	Not in use.
InterlockDoor	0.500	0.500		Calc	For PBS Vertical-Wheel® Bioreactors with a door, this indicates whether the door will not unlock because it is interlocked.
InterlockDoorPressureMax (psi)	0.001	0.001		System	See Safety “Max Pressure Door (psi)” setting in Appendix 1.
InterlockGasFlow	0.500	0.500		Calc	Indicates whether gases will not flow because they are interlocked.
InterlockHeater	0.500	0.500		Calc	Indicates whether main heater will not turn on because temperature is interlocked.
InterlockPressureMax(psi)	0.001	0.001		System	See Safety “Max Pressure (psi)” setting in Appendix 1.
InterlockPumps	0.500	0.500		Calc	Indicates whether media and additions pumps will not turn on because they are interlocked.
InterlockTempMax(C)	0.001	0.001		System	See Safety “Max Temp (C)” setting in Appendix 1.

LEDS

Variable Name	Default Deadband		Default Record	Source	Definition
	PBS-15	PBS-80			
LEDWhiteLEDOn	0.500	0.500		User	The user can set this to true to turn on the white light in the chamber.

LEVEL

Variable Name	Default Deadband		Default Record	Source	Definition
	PBS-15	PBS-80			
LevelCalCluster.Bottom Gap (cm)	0.001	0.001		System	See Level “Bottom Gap (cm)” setting in Appendix 1.
LevelCalCluster.Cm/psi	0.001	0.001		System	See Level “cm/psi” setting in Appendix 1.
LevelCalCluster.Depth	0.001	0.001		System	See Level “Vessel Depth (cm)” setting in Appendix 1.
LevelCalCluster.Level Empty(L)	0.001	0.001		System	See Level “Empty Level (L)” setting in Appendix 1.
LevelCalCluster.Level Empty(V)	0.001	0.001		System	See Level “Empty Level (V)” setting in Appendix 1.
LevelCalCluster.Radius (cm)	0.001	0.001		System	See Level “Radius (cm)” setting in Appendix 1.
LevelColumn(psi)	0.100	0.500		Calc	The raw voltage times level slope plus level intercept. For the PBS 3 models, this is the level PV. For larger models, this corresponds to the pressure the level sensor measures.
LevelMax(L)	0.001	0.001		System	See Safety “Max Level (L)” setting in Appendix 1.
LevelMin(L)	0.001	0.001		System	See Safety “Min Level (L)” setting in Appendix 1.

LEVEL (continued)

Variable Name	Default Deadband		Default Record	Source	Definition
	PBS-15	PBS-80			
LevelNet(cm)	1.000	5.000		Calc	For PBS Vertical-Wheel® Bioreactors with a pressure sensor, the level net pressure times the cm/psi.
LevelNoCal(L)	0.750	4.000		Calc	Not in use.
LevelPV(L)	0.500	2.500	✓	Calc	The level of the bag contents detected by the software.
LevelRaw(V)	0.100	0.100		Sensor	The raw voltage the level sensor reports.
LevelSensorEnable	0.500	0.500		System	See Level “Enable Sensor (0 or 1)” setting in Appendix 1.
LevelTotal(cm)	1.000	5.000		Calc	For PBS Vertical-Wheel® Bioreactors with a pressure sensor, the net level plus the bottom gap.

PROCESS ALARMS/LIMITS

Variable Name	Default Deadband		Default Record	Source	Definition
	PBS-15	PBS-80			
Limits.Agitation High (RPM)	0.001	0.001		System	See Process Alarms “Agitation High (RPM)” setting in Appendix 1.
Limits.Agitation High High (RPM)	0.001	0.001		System	See Process Alarms “Agitation High High (RPM)” setting in Appendix 1.
Limits.Agitation Low (RPM)	0.001	0.001		System	See Process Alarms “Agitation Low (RPM)” setting in Appendix 1.
Limits.Agitation Low Low (RPM)	0.001	0.001		System	See Process Alarms “Agitation Low Low (RPM)” setting in Appendix 1.

PROCESS ALARMS/LIMITS (continued)

Variable Name	Default Deadband		Default Record	Source	Definition
	PBS-15	PBS-80			
Limits.DO High (%)	0.001	0.001		System	See Process Alarms “DO High (%)” setting in Appendix 1.
Limits.DO High High (%)	0.001	0.001		System	See Process Alarms “DO High High (%)” setting in Appendix 1.
Limits.DO Low (%)	0.001	0.001		System	See Process Alarms “DO Low (%)” setting in Appendix 1.
Limits.DO Low Low (%)	0.001	0.001		System	See Process Alarms “DO Low Low (%)” setting in Appendix 1.
Limits.Filter Oven High (C)	0.001	0.001		System	See Process Alarms “Filter Oven High (C)” setting in Appendix 1.
Limits.Filter Oven High High (C)	0.001	0.001		System	See Process Alarms “Filter Oven High High (C)” setting in Appendix 1.
Limits.Filter Oven Low (C)	0.001	0.001		System	See Process Alarms “Filter Oven Low (C)” setting in Appendix 1.
Limits.Filter Oven Low Low (C)	0.001	0.001		System	See Process Alarms “Filter Oven Low Low (C)” setting in Appendix 1.
Limits.Level High (L)	0.001	0.001		System	See Process Alarms “Level High (L)” setting in Appendix 1.
Limits.Level High High (L)	0.001	0.001		System	See Process Alarms “Level High High (L)” setting in Appendix 1.
Limits.Level Low (L)	0.001	0.001		System	See Process Alarms “Level Low (L)” setting in Appendix 1.
Limits.Level Low Low (L)	0.001	0.001		System	See Process Alarms “Level Low Low (L)” setting in Appendix 1.

PROCESS ALARMS/LIMITS (continued)

Variable Name	Default Deadband		Default Record	Source	Definition
	PBS-15	PBS-80			
Limits.Main Gas High (LPM)	0.001	0.001		System	See Process Alarms “Main Gas High (LPM)” setting in Appendix 1.
Limits.Main Gas High High (LPM)	0.001	0.001		System	See Process Alarms “Main Gas High High (LPM)” setting in Appendix 1.
Limits.Main Gas Low (LPM)	0.001	0.001		System	See Process Alarms “Main Gas Low (LPM)” setting in Appendix 1.
Limits.Main Gas Low Low (LPM)	0.001	0.001		System	See Process Alarms “Main Gas Low Low (LPM)” setting in Appendix 1.
Limits.Pressure High (psi)	0.001	0.001		System	See Process Alarms “Pressure High (psi)” setting in Appendix 1.
Limits.Pressure High High (psi)	0.001	0.001		System	See Process Alarms “Pressure High High (psi)” setting in Appendix 1.
Limits.Pressure Low (psi)	0.001	0.001		System	See Process Alarms “Pressure Low (psi)” setting in Appendix 1.
Limits.Pressure Low Low (psi)	0.001	0.001		System	See Process Alarms “Pressure Low Low (psi)” setting in Appendix 1.
Limits.Temp High (C)	0.001	0.001		System	See Process Alarms “Temp High (C)” setting in Appendix 1.
Limits.Temp High High (C)	0.001	0.001		System	See Process Alarms “Temp High High (C)” setting in Appendix 1.
Limits.Temp Low (C)	0.001	0.001		System	See Process Alarms “Temp Low (C)” setting in Appendix 1.

PROCESS ALARMS/LIMITS (continued)

Variable Name	Default Deadband		Default Record	Source	Definition
	PBS-15	PBS-80			
Limits.Temp Low Low (C)	0.001	0.001		System	See Process Alarms “Temp Low Low (C)” setting in Appendix 1.
Limits.pH High	0.001	0.001		System	See Process Alarms “pH High” setting in Appendix 1.
Limits.pH High High	0.001	0.001		System	See Process Alarms “pH High High” setting in Appendix 1.
Limits.pH Low	0.001	0.001		System	See Process Alarms “pH Low” setting in Appendix 1.
Limits.pH Low Low	0.001	0.001		System	See Process Alarms “pH Low Low” setting in Appendix 1.
SensorStates.Agitation	0.500	0.500		Calc	The state of the sensor with regard to Process Alarms and failures: 1) In Range, 2) Above High, 3) Below Low, 4) Above High High, 5) Below Low Low, and 6) Broken Sensor Mode.
SensorStates.DO	0.500	0.500		Calc	The state of the sensor with regard to Process Alarms and failures: 1) In Range, 2) Above High, 3) Below Low, 4) Above High High, 5) Below Low Low, and 6) Broken Sensor Mode.
SensorStates.Filter Oven	0.500	0.500		Calc	The state of the sensor with regard to Process Alarms and failures: 1) In Range, 2) Above High, 3) Below Low, 4) Above High High, 5) Below Low Low, and 6) Broken Sensor Mode.

PROCESS ALARMS/LIMITS (continued)

Variable Name	Default Deadband		Default Record	Source	Definition
	PBS-15	PBS-80			
SensorStates.Level	0.500	0.500		Calc	The state of the sensor with regard to Process Alarms and failures: 1) In Range, 2) Above High, 3) Below Low, 4) Above High High, and 5) Below Low Low.
SensorStates.Main Gas	0.500	0.500		Calc	The state of the sensor with regard to Process Alarms and failures: 1) In Range, 2) Above High, 3) Below Low, 4) Above High High, and 5) Below Low Low.
SensorStates.Pressure	0.500	0.500		Calc	The state of the sensor with regard to Process Alarms and failures: 1) In Range, 2) Above High, 3) Below Low, 4) Above High High, and 5) Below Low Low.
SensorStates.Temperature	0.500	0.500		Calc	The state of the sensor with regard to Process Alarms and failures: 1) In Range, 2) Above High, 3) Below Low, 4) Above High High, 5) Below Low Low, and 6) Broken Sensor Mode.
SensorStates.pH	0.500	0.500		Calc	The state of the sensor with regard to Process Alarms and failures: 1) In Range, 2) Above High, 3) Below Low, 4) Above High High, 5) Below Low Low, and 6) Broken Sensor Mode.

LOGGER

Variable Name	Default Deadband		Default Record	Source	Definition
	PBS-15	PBS-80			
LoggerLoadedCount	0.500	0.500		Calc	Tracks the number of times logger settings have been loaded from file.
LoggerMaxLogInterval(ms)	60.000	60.000		System	See System “Max Data Log Interval (min)” setting in Appendix 1.

MAIN GAS

Variable Name	Default Deadband		Default Record	Source	Definition
	PBS-15	PBS-80			
MainGasActualRequest (LPM)	0.400	2.000	✓	Calc	The gas flow output the controller requests of the main gas MFCs.
MainGasFeedback(LPM)	0.400	2.000		Calc	The sum of the actual flows of the Air, N ₂ , CO ₂ , and O ₂ MFCs.
MainGasModeActual	0.500	0.500	✓	Calc	The actual main gas mode: 0) Auto, 1) Manual, and 2) Off.
MainGasModeUser	0.500	0.500		User	The user-requested main gas mode: 0) Auto, 1) Manual, and 2) Off.
MainGasRangeManMax (LPM)	0.001	0.001		System	See Gas Data “Manual Max (LPM)” setting in Appendix 1.
MainGasUser(LPM)	0.400	2.000	✓	User	The last user-defined flow rate used when main gas was in Manual mode.

PRESSURE

Variable Name	Default Deadband		Default Record	Source	Definition
	PBS-15	PBS-80			
PressureDisconnected(V)	0.001	0.001		System	See Pressure “Disconnected Pressure (V)” setting in Appendix 1.

PRESSURE (continued)

Variable Name	Default Deadband		Default Record	Source	Definition
	PBS-15	PBS-80			
PressurePV(psi)	0.050	0.050	✓	Calc	For PBS Vertical-Wheel® Bioreactors with a pressure sensor, the pressure in the bag detected by the software.
PressureRaw(V)	0.100	0.100		Sensor	For PBS Vertical-Wheel® Bioreactors with a pressure sensor, the raw voltage the pressure sensor reports.
PressureSensorIsActive	0.500	0.500		Calc	For PBS Vertical-Wheel® Bioreactors with a pressure sensor, this indicates if the pressure sensor is disconnected.
Reusable Sensor (0 or 1)	0.500	0.500		System	See Pressure “Reusable Sensor (0 or 1)” setting in Appendix 1.

PUMPS AND VALVES

Variable Name	Default Deadband		Default Record	Source	Definition
	PBS-15	PBS-80			
Pumps&ValvesAddition AHardware.AllowAsBase	0.500	0.500		System	A configuration set at the factory to tell the software if the Addition A pump can be used as the Base pump. This variable should not be modified via recipe.
Pumps&ValvesAddition AHardware.Exists	0.500	0.500		System	A configuration set at the factory to tell the software if an Addition A pump is installed. This variable should not be modified via recipe.

PUMPS AND VALVES (continued)

Variable Name	Default Deadband		Default Record	Source	Definition
	PBS-15	PBS-80			
Pumps&ValvesAddition AHardware.Reversible	0.500	0.500		System	A configuration set at the factory to tell the software if the Addition A pump hardware supports bi-directional flow. This variable should not be modified via recipe.
Pumps&ValvesAddition AHardware.SpeedControl	0.500	0.500		System	A configuration set at the factory to tell the software what method of speed control for the Addition A pump is supported by the hardware: 0) Off/On, 1) Slow/Medium/Fast, and 2) RPM control. This variable should not be modified via recipe.
Pumps&ValvesAddition BHardware.AllowAsBase	0.500	0.500		System	A configuration set at the factory to tell the software if the Addition B pump can be used as the Base pump. This variable should not be modified via recipe.
Pumps&ValvesAddition BHardware.Exists	0.500	0.500		System	A configuration set at the factory to tell the software if an Addition B pump is installed. This variable should not be modified via recipe.
Pumps&ValvesAddition BHardware.Reversible	0.500	0.500		System	A configuration set at the factory to tell the software if the Addition B pump hardware supports bi-directional flow. This variable should not be modified via recipe.

PUMPS AND VALVES (continued)

Variable Name	Default Deadband		Default Record	Source	Definition
	PBS-15	PBS-80			
Pumps&ValvesAddition BHardware.SpeedControl	0.500	0.500		System	A configuration set at the factory to tell the software what method of speed control for the Addition B pump is supported by the hardware: 0) Off/On, 1) Slow/Medium/Fast, and 2) RPM control. This variable should not be modified via recipe.
Pumps&ValvesAnalogBase Speed(RPM)	1.000	1.000		System	See Pumps “Analog Base Speed (RPM)” setting in Appendix 1.
Pumps&ValvesBaseMax Period(s)	0.001	0.001		System	See Pumps “Base Max Period (s)” setting in Appendix 1.
Pumps&ValvesBaseOn Time(s)	0.001	0.001		System	See Pumps “Base On Time (s)” setting in Appendix 1.
Pumps&ValvesBasePump Selection	0.500	0.500	✓	User	The selector of which pump is the base pump: 0) No base pump selected, 1) addition pump A, or 2) addition pump B.
Pumps&ValvesFillMotor Raw(V)	0.100	0.100		Calc	For PBS Vertical-Wheel® Bioreactors with an RPM-controllable media pump, this is the voltage to output to the media pump motor.
Pumps&ValvesFillMotor Raw(V) 2	0.100	0.100		Calc	(N/A on PBS-15) For PBS Vertical-Wheel® Bioreactors with an RPM-controllable addition pump A, this is the voltage to output to the addition pump A motor.

PUMPS AND VALVES (continued)

Variable Name	Default Deadband		Default Record	Source	Definition
	PBS-15	PBS-80			
Pumps&ValvesFillMotor Raw(V) 3	0.100	0.100		Calc	(N/A on PBS-15/80) For PBS Vertical-Wheel® Bioreactors with an RPM-controllable addition pump B, this is the voltage to output to the addition pump B motor.
Pumps&ValvesFillSpeed (RPM)	5.000	5.000		User	For PBS Vertical-Wheel® Bioreactors with an RPM-controllable media pump, this is the speed at which the user wants the media pump to turn. For other models, a value of 0 means the media pump is off and a higher number means it is on.
Pumps&ValvesFillSpeed (RPM) 2	5.000	5.000		User	(N/A on PBS-15) For PBS Vertical-Wheel® Bioreactors with an RPM-controllable addition pump A, this is the speed at which the user wants the addition pump A to turn. For other models, this variable should not be modified via recipe.
Pumps&ValvesFillSpeed (RPM) 3	5.000	5.000		User	(N/A on PBS-15/80) For PBS Vertical-Wheel® Bioreactors with an RPM-controllable addition pump B, this is the speed at which the user wants the addition pump B to turn. For other models, this variable should not be modified via recipe.

PUMPS AND VALVES (continued)

Variable Name	Default Deadband		Default Record	Source	Definition
	PBS-15	PBS-80			
Pumps&ValvesMedia Hardware.AllowAsBase	0.500	0.500		System	A configuration set at the factory to tell the software if the Media pump can be used as the Base pump. This variable should not be modified via recipe.
Pumps&ValvesMedia Hardware.Exists	0.500	0.500		System	A configuration set at the factory to tell the software if a Media pump is installed. This variable should not be modified via recipe.
Pumps&ValvesMedia Hardware.Reversible	0.500	0.500		System	A configuration set at the factory to tell the software if the Media pump hardware supports bi-directional flow. This variable should not be modified via recipe.
Pumps&ValvesMedia Hardware.SpeedControl	0.500	0.500		System	A configuration set at the factory to tell the software what method of speed control for the Media pump is supported by the hardware: 0) Off/On, 1) Slow/Medium/Fast, and 2) RPM control. This variable should not be modified via recipe.
Pumps&Valves Pump1.Duty	1.000	1.000		Calc	The pulse-density modulation duty for addition pump A. 2^{16} would be 100% duty.

PUMPS AND VALVES (continued)

Variable Name	Default Deadband		Default Record	Source	Definition
	PBS-15	PBS-80			
Pumps&ValvesPump1.On Time(Cycle)	10.000	10.000		Calc	The time that addition pump A stays on each period, in number of cycles of the hardware writing to addition pump A, when addition pump A is the base pump. 1 iter $\approx 36 \mu\text{s}$.
Pumps&Valves Pump1.Period(Cycle)	10.000	10.000		Calc	The pulse-density modulation period for addition pump A, in number of iterations of the hardware writing to the pumps. 1 iter $\approx 36 \mu\text{s}$.
Pumps&Valves Pump2.Duty	1.000	1.000		Calc	The pulse-density modulation duty for addition pump B. 2^{16} would be 100% duty.
Pumps&ValvesPump2.On Time(Cycle)	10.000	10.000		Calc	The time that addition pump B stays on each period, in number of cycles of the hardware writing to addition pump A, when addition pump B is the base pump. 1 iter $\approx 36 \mu\text{s}$.
Pumps&Valves Pump2.Period(Cycle)	10.000	10.000		Calc	The pulse-density modulation period for addition pump B, in number of iterations of the hardware writing to the pumps. 1 iter $\approx 36 \mu\text{s}$.
Pumps&ValvesPumpLow AuxSpeed	1.000	1.000		System	See Pumps “Aux Low Duty” setting in Appendix 1.
Pumps&ValvesPumpMed AuxSpeed	1.000	1.000		System	See Pumps “Aux Med Duty” setting in Appendix 1.

PUMPS AND VALVES (continued)

Variable Name	Default Deadband		Default Record	Source	Definition
	PBS-15	PBS-80			
Pumps&ValvesPumpSmpl	0.500	0.500		Calc	True when the Sample Pump is on.
Pumps&ValvesPumpSmpl Req	0.500	0.500		User	The user sets this to true to request the sample pump to run.
Pumps&ValvesPumpSmpl Revrs	0.500	0.500		Calc	This toggles the sample pump direction.
Pumps&ValvesPumpSmpl RevrsReq	0.500	0.500		User	The user can toggle this to change pump direction.
Pumps&ValvesPumpUser1	0.500	0.500	✓	User	For PBS Vertical-Wheel® Bioreactors with speed-controllable addition pumps, this is the user-requested addition pump A speed: 0) Off, 1) Slow, 2) Medium, 3) Fast.
Pumps&ValvesPumpUser2	0.500	0.500	✓	User	For PBS Vertical-Wheel® Bioreactors with speed-controllable addition pumps, this is the user-requested addition pump B speed: 0) Off, 1) Slow, 2) Medium, 3) Fast.
Pumps&ValvesReverse CCandCW	0.500	0.500		System	See Pumps “Sample Reverse CW and CCW (0 or 1)” setting in Appendix 1.
Pumps&ValvesSample Hardware.AllowAsBase	0.500	0.500		System	A configuration set at the factory to tell the software if the Sample pump can be used as the Base pump. This variable should not be modified via recipe.

PUMPS AND VALVES (continued)

Variable Name	Default Deadband		Default Record	Source	Definition
	PBS-15	PBS-80			
Pumps&ValvesSample Hardware.Exists	0.500	0.500		System	A configuration set at the factory to tell the software if a Sample pump is installed. This variable should not be modified via recipe.
Pumps&ValvesSample Hardware.Reversible	0.500	0.500		System	A configuration set at the factory to tell the software if the Sample pump hardware supports bi-directional flow. This variable should not be modified via recipe.
Pumps&ValvesSample Hardware.SpeedControl	0.500	0.500		System	A configuration set at the factory to tell the software what method of speed control for the Sample pump is supported by the hardware: 0) Off/On, 1) Slow/Medium/Fast, and 2) RPM control. This variable should not be modified via recipe.

RECIPE

Variable Name	Default Deadband		Default Record	Source	Definition
	PBS-15	PBS-80			
PromptIssued(tick)	0.100	0.100		Calc	Not in use.
Recipe Index	0.500	0.500		Calc	The step the recipe is currently on. Value is -1 when no recipe is running, 0 for first step, 1 for second step, etc.
RecipeSkipSequence	0.500	0.500		User	True when the user wants to skip past the sequence in the recipe engine. The variable automatically changes back.

RECIPE (continued)

Variable Name	Default Deadband		Default Record	Source	Definition
	PBS-15	PBS-80			
RecipeSkipStep	0.500	0.500		User	True when the user wants to skip past the current step in the recipe engine. The variable automatically changes back.

SYSTEM

Variable Name	Default Deadband		Default Record	Source	Definition
	PBS-15	PBS-80			
BioreactorModel	0.500	0.500		System	The model of the PBS Vertical-Wheel® Bioreactor. This variable should not be modified via recipe.
SysAvailableMem(KB)	0.001	0.001		System	Available memory on the RIO computer (kilobytes).
SysAvailableMemLimit(KB)	0.001	0.001		System	See System “Available Mem Limit (KB)” setting in Appendix 1.
SysLCBMem(KB)	0.001	0.001		System	Size (kilobytes) of the largest contiguous block (LCB) of memory on the RIO computer.
SysLCBMemLimit(KB)	0.001	0.001		System	See System “LCB Mem Limit (KB)” setting in Appendix 1.
SysSessionID	0.500	0.500		System	A unique session handle – used to confirm the RIO computer rebooted successfully
SysStop	0.500	0.500		System	Used to initiate a request to reboot the RIO computer.
Sys_FPGAError.NI 9205	0.500	0.500		Sensor	The status used to trigger the “NI 9205 Error” alarm.

SYSTEM (continued)

Variable Name	Default Deadband		Default Record	Source	Definition
	PBS-15	PBS-80			
Sys_FPGAError.NI 9219	0.500	0.500		Sensor	The status used to trigger the “NI 9219 Error” alarm.
Sys_FPGAError.NI 9263	0.500	0.500		Sensor	The status used to trigger the “NI 9263 Error” alarm.
Sys_FPGAError.NI 9425/Onboard	0.500	0.500		Sensor	The status used to trigger the “NI 9425/Onboard Error” alarm.
Sys_FPGAError.NI 9476	0.500	0.500		Sensor	The status used to trigger the “NI 9476 Error” alarm.
Sys_PWMLoopTime (ticks/Cycle)	1.000	1.000		Sensor	The length of time, in ticks, of 1 cycle of the hardware writing to the NI 9476. 1 tick = 25 ns.
Sys_StartupCond	0.500	0.500		System	Outputs how the last shutdown of the RIO computer occurred. Used to trigger “Dirty Startup”, “Clean Startup”, and “Resume” alarms.

TEMPERATURE

Variable Name	Default Deadband		Default Record	Source	Definition
	PBS-15	PBS-80			
TempA(C)	0.200	0.200		Calc	The PV reported by temperature sensor A.
TempAlsActive	0.500	0.500		Calc	True when temperature sensor A has not failed.
TempAlsPrimaryActual	0.500	0.500	✓	Calc	True when the software reports temperature PV as what temperature sensor A measures.

TEMPERATURE (continued)

Variable Name	Default Deadband		Default Record	Source	Definition
	PBS-15	PBS-80			
TempAlsPrimaryUser	0.500	0.500		User	For PBS Vertical-Wheel® Bioreactors with duplicate temperature sensors, true when the user prefers that the software reports temperature PV as what temperature sensor A measures.
TempARaw(C)	0.100	0.100		Sensor	The raw resistance temperature sensor A reports.
TempAtLeast1GoodSensor	0.500	0.500		Calc	Indicates if at least 1 temperature sensor has not failed.
TempB(C)	0.200	0.200		Calc	For PBS Vertical-Wheel® Bioreactors with duplicate temperature sensors, the PV reported by temperature sensor B.
TempBIsActive	0.500	0.500		Calc	For PBS Vertical-Wheel® Bioreactors with duplicate temperature sensors, true when temperature sensor B has not failed.
TempBRaw(C)	0.100	0.100		Sensor	For PBS Vertical-Wheel® Bioreactors with duplicate temperature sensors, the raw resistance temperature sensor B reports.
TempHardware	0.500	0.500		System	A configuration set at the factory to tell the software which temperature sensors the hardware supports. This variable should not be modified via recipe.

TEMPERATURE (continued)

Variable Name	Default Deadband		Default Record	Source	Definition
	PBS-15	PBS-80			
TempHeatDutyActual(%)	2.000	2.000	✓	Calc	The heat duty of the main heater.
TempHeatDutyAutoMax(%)	0.001	0.001		System	See Temperature “Heat Auto Max (%)” setting in Appendix 1.
TempHeatDutyControl.DTime(min)	0.001	0.001		System	See Temperature “D Time (min)” setting in Appendix 1.
TempHeatDutyControl.ITime(min)	0.001	0.001		System	See Temperature “I Time (min)” setting in Appendix 1.
TempHeatDutyControl.PGain(min)	0.001	0.001		System	See Temperature “P Gain (%/C)” setting in Appendix 1.
TempHeatDutyControl Alpha	0.001	0.001		System	See Temperature “Alpha” setting in Appendix 1.
TempHeatDutyControlBeta	0.001	0.001		System	See Temperature “Beta” setting in Appendix 1.
TempHeatDutyControl Gamma	0.001	0.001		System	See Temperature “Gamma” setting in Appendix 1.
TempHeatDutyControl Linearity	0.001	0.001		System	See Temperature “Linearity” setting in Appendix 1.
TempHeatDutyUser(%)	1.000	1.000	✓	User	The last user-defined heat duty used when temperature was in Manual mode.
TempHeatManMax(%)	0.001	0.001		System	See Temperature “Heat Manual Max (%)” setting in Appendix 1.
TempHeatOnTime(Cycle)	1.000	1.000		Calc	The time that the main heater stays on each period, in number of cycles of the hardware writing to the main heater. 1 Cycle \approx 36 μ s.

TEMPERATURE (continued)

Variable Name	Default Deadband		Default Record	Source	Definition
	PBS-15	PBS-80			
TempHeatPeriod(Cycle)	1.000	1.000		Calc	The pulse width modulation period for the main heater, in number of cycles of the hardware writing to the main heater. Corresponds to 1 second. 1 Cycle \approx 36 μ s.
TempInRange.A	0.500	0.500		Calc	True when temperature sensor A is in valid range.
TempInRange.B	0.500	0.500		Calc	For PBS Vertical-Wheel [®] Bioreactors with duplicate temperature sensors, true when temperature sensor B is in valid range.
TempMismatchThresh(C)	0.001	0.001		System	See Temperature “Mismatch Thresh (C)” setting in Appendix 1.
TempModeActual	0.500	0.500	✓	Calc	The actual temperature mode: 0) Auto, 1) Manual, 2) Off, and 3) Broken Sensor.
TempModeUser	0.500	0.500		User	The user-requested temperature mode: 0) Auto, 1) Manual, and 2) Off.
TempPV(C)	0.200	0.200	✓	Calc	The temperature value detected by the software.
TempSP(C)	0.100	0.100	✓	User	The last temperature set point used when temperature was in Auto mode.

TEMPERATURE (continued)

Variable Name	Default Deadband		Default Record	Source	Definition
	PBS-15	PBS-80			
TempUserConfig	0.500	0.500		User	For PBS Vertical-Wheel® Bioreactors with duplicate temperature sensors, a user configuration to tell the software which temperature sensors the user has installed.
TempValidMax(C)	0.001	0.001		System	See Temperature “Valid High (C)” setting in Appendix 1.
TempValidMin(C)	0.001	0.001		System	See Temperature “Valid Low (C)” setting in Appendix 1.

pH

Variable Name	Default Deadband		Default Record	Source	Definition
	PBS-15	PBS-80			
pHA	0.050	0.050		Calc	The PV reported by pH sensor A.
pHAIsActive	0.500	0.500		Calc	True when pH sensor A has not failed.
pHAIsPrimaryActual	0.500	0.500		Calc	True when the software reports pH PV as what pH sensor A measures.
pHAIsPrimaryUser	0.500	0.500		User	For PBS Vertical-Wheel® Bioreactors with duplicate pH sensors, true when the user prefers that the software reports pH PV as what pH sensor A measures.
pHARaw	0.010	0.010		Sensor	The raw voltage pH sensor A reports.
pHAUseTempComp	0.500	0.500		System	See pH “A Use Temp Comp?” setting in Appendix 1.

pH (continued)

Variable Name	Default Deadband		Default Record	Source	Definition
	PBS-15	PBS-80			
pHActiveMode	0.500	0.500		Calc	In Auto mode, indicates if the controller is: 0) lowering the pH, 1) in the deadband, or 2) raising pH.
pHAtLeast1GoodSensor	0.500	0.500		Calc	Indicates if at least 1 pH sensor has not failed.
pHB	0.050	0.050		Calc	(N/A on PBS-15/80) For PBS Vertical-Wheel® Bioreactors with duplicate pH sensors, the PV reported by pH sensor B.
pHBIsActive	0.500	0.500		Calc	(N/A on PBS-15/80) For PBS Vertical-Wheel® Bioreactors with duplicate pH sensors, true when pH sensor B has not failed.
pHBRaw	0.010	0.010		Sensor	(N/A on PBS-15/80) For PBS Vertical-Wheel® Bioreactors with duplicate pH sensors, the raw voltage pH sensor B reports.
pHBUseTempComp	0.500	0.500		System	See pH “B Use Temp Comp?” setting in Appendix 1.
pHBaseAutoMax	0.001	0.001		System	See pH “Base Auto Max (%)” setting in Appendix 1.
pHBaseDutyActual(%)	1.000	1.000	✓	Calc	The base pump output.
pHBaseDutyControl.DTime (min)	0.001	0.001		System	See pH “Base D Time (min)” setting in Appendix 1.
pHBaseDutyControl.ITime (min)	0.001	0.001		System	See pH “Base I Time (min)” setting in Appendix 1.

pH (continued)

Variable Name	Default Deadband		Default Record	Source	Definition
	PBS-15	PBS-80			
pHBaseDutyControl.PGain (%)	0.001	0.001		System	See pH “Base P Gain (%/pH)” setting in Appendix 1.
pHBaseDutyControlAlpha	0.001	0.001		System	See pH “Base Alpha” setting in Appendix 1.
pHBaseDutyControlBeta	0.001	0.001		System	See pH “Base Beta” setting in Appendix 1.
pHBaseDutyControl Gamma	0.001	0.001		System	See pH “Base Gamma” setting in Appendix 1.
pHBaseDutyControl Linearity	0.001	0.001		System	See pH “Base Linearity” setting in Appendix 1.
pHBaseDutyManMax(%)	0.001	0.001		System	See pH “Base Manual Max (%)” setting in Appendix 1.
pHBaseDutyUser(%)	1.000	1.000	✓	User	The last user-defined base pump output used when pH was in Manual mode.
pHCO2ActualRequest(%)	1.000	1.000	✓	Calc	The CO ₂ flow output the software actually requests from the CO ₂ MFC, in percent of main gas flow. It limits the CO ₂ flow the pH controller requests by taking the maximum CO ₂ MFC flow and the requested main gas flow into account.
pHCO2AutoMax(%)	0.001	0.001		System	See pH “CO ₂ Auto Max (%)” setting in Appendix 1.
pHCO2Control.DTime(min)	0.001	0.001		System	See pH “CO ₂ D Time (min)” setting in Appendix 1.
pHCO2Control.ITime(min)	0.001	0.001		System	See pH “CO ₂ I Time (min)” setting in Appendix 1.

pH (continued)

Variable Name	Default Deadband		Default Record	Source	Definition
	PBS-15	PBS-80			
pHCO2Control.PGain(%)	0.001	0.001		System	See pH “CO2 P Gain (%/pH)” setting in Appendix 1.
pHCO2ControlAlpha	0.001	0.001		System	See pH “CO2 Alpha” setting in Appendix 1.
pHCO2ControlBeta	0.001	0.001		System	See pH “CO2 Beta” setting in Appendix 1.
pHCO2ControlGamma	0.001	0.001		System	See pH “CO2 Gamma” setting in Appendix 1.
pHCO2ControlLinearity	0.001	0.001		System	See pH “CO2 Linearity” setting in Appendix 1.
pHCO2FlowController Request(%)	1.000	1.000		Calc	The CO ₂ flow output requested by the pH controller, in percent of main gas flow.
pHCO2ManMax(%)	0.001	0.001		System	See pH “CO2 Manual Max (%)” setting in Appendix 1.
pHCO2User(%)	1.000	1.000		User	The last user-defined CO ₂ output used when pH was in Manual mode.
pHDeadband	0.001	0.001	✓	System	See pH “Deadband” setting in Appendix 1.
pHHardware	0.500	0.500		System	A configuration set at the factory to tell the software which pH sensors the hardware supports. This variable should not be modified via recipe.
pHInRange.A	0.500	0.500		Calc	True when pH sensor A is in valid range.
pHInRange.B	0.500	0.500		Calc	(N/A on PBS-15/80) For PBS Vertical-Wheel [®] Bioreactors with duplicate pH sensors, true when pH sensor B is in valid range.

pH (continued)

Variable Name	Default Deadband		Default Record	Source	Definition
	PBS-15	PBS-80			
pHMismatchThresh	0.001	0.001		System	See pH “Mismatch Thresh” setting in Appendix 1.
pHModeActual	0.500	0.500	✓	Calc	The actual pH mode: 0) Auto, 1) Manual, 2) Off, and 3) Broken Sensor.
pHModeUser	0.500	0.500		User	The user-requested pH mode: 0) Auto, 1) Manual, and 2) Off.
pHPV	0.050	0.050	✓	Calc	The pH value detected by the software.
pHRateFailDeltaPV	0.001	0.001		System	See pH “Rate Fail Delta PV” setting in Appendix 1.
pHRateFailDeltaTime(ms)	1.000	1.000		System	See pH “Rate Fail Delta Time (s)” setting in Appendix 1.
pHSP	0.010	0.010	✓	User	The last pH set point used when pH was in Auto mode.
pHSensorSamplesTo Average	0.500	0.500		System	See pH “Samples To Average” setting in Appendix 1.
pHUserConfig	0.500	0.500		User	(N/A on PBS-15/80) For PBS Vertical-Wheel® Bioreactors with duplicate pH sensors, a user configuration to tell the software which pH sensors the user has installed.
pHValidMax	0.001	0.001		System	See pH “Valid High (pH)” setting in Appendix 1.
pHValidMin	0.001	0.001		System	See pH “Valid Low (pH)” setting in Appendix 1.